

6

(Anal.)

**FIRST PART**  
OF THE  
**TWENTIETH VOLUME**  
OF  
**ASIATIC RESEARCHES;**  
OR,  
**Transactions of the Society,**  
INSTITUTED IN BENGAL,  
FOR ENQUIRING INTO  
THE HISTORY, THE ANTIQUITIES, THE ARTS AND  
SCIENCES, AND LITERATURE  
OF  
**A S I A.**

---

2. **CALCUTTA:**

PRINTED AT THE BENGAL MILITARY ORPHAN PRESS,  
BY G. H. HUTTMANN.

---

1836.

~~LSoc 2436.1~~

Ind 2.6

HARVARD COLLEGE LIBRARY

1657  
622.3  
43-229  
71

CONTENTS  
OF THE  
FIRST PART OF THE 20th VOLUME.

---

	<i>Page</i>
<b>I.</b>	
<i>Translation of various Inscriptions found among the Ruins of Vijayanagar. By E. C. Ravenshaw, Esq., Bengal Civil Service. With Preliminary Observations, by H. H. Wilson, Esq., late Secretary of the Asiatic Society, . . . . .</i>	<b>1</b>
<b>II.</b>	
⊙ <i>Analysis of the Dulva, a Portion of the Tibetan Work entitled the Kah-Gyur. By Mr. Alexander Csoma Körösi, Siculo-Hungarian of Transylvania, . . . . .</i>	<b>41</b>
<b>III.</b>	
<i>On the Administration of Justice in Nepál, with some account of the several Courts, extent of their Jurisdiction, and modes of Procedure. By B. H. Hodgson, Esq., British Resident in Nepál, . . . . .</i>	<b>94</b>
<b>IV.</b>	
<i>Essay on Sanscrit Alliteration. By the Rev. William Yates, . . . . .</i>	<b>135</b>
<b>V.</b>	
<i>Translation of an Inscription in the Burmese Language, discovered at Buddha Gaya, in 1833. By Lieutenant-Colonel H. Burney, British Resident at Ava, . . . . .</i>	<b>161</b>
<b>VI.</b>	
<i>Results of an Enquiry respecting the Law of Mortality, for British India, deduced from the Reports and Appendices of the Committee appointed by the Bengal Government in 1834, to consider the expediency of a Government Life Assurance Institution. By Captain H. B. Henderson, Asst. Mily. Audr. Genl., Secretary to the Committee, . . . . .</i>	<b>190</b>





I.

---

TRANSLATION  
OF  
VARIOUS INSCRIPTIONS FOUND AMONG  
THE  
RUINS OF VIJAYANAGAR.

---

By E. C. RAVENSHAW, Esq.  
Bengal Civil Service.

WITH PRELIMINARY OBSERVATIONS,  
By H. H. WILSON, Esq.  
*Late Secretary of the Asiatic Society.*

---

THE history of *Vijayanagar* is a subject of considerable interest in the annals of India, as the last barrier that was opposed to Muhammedan invasions, and that preserved the southern part of the Peninsula from foreign rule until a very modern period.

The history of this State enjoys, consequently, the advantage of receiving frequent illustration from Muhammedan authors, and some even from Christian writers, as it survived about half a century the arrival of the Portuguese in India. Reliques of its importance exist also in the Peninsula in great numbers, not only in the remains of the capital, and towns, and

▲

temples, founded by its rulers, or their chief officers, but in innumerable inscriptions recording grants and endowments by the same, and specifying the names and dates of the ruling prince, with occasional genealogical details. It has a still further advantage in the existence of individuals descended from the royal family at the period of its subversion, and who preserve the memory of their ancestry, if not the hope of recovering the dignity which their predecessors enjoyed.

The documents now presented to the Society, by Mr. RAVENSHAW, relate to the *Vijayanagar* principality, and consist of copies and translations of fifteen inscriptions, and a pedigree of the kings of *Vijayanagar*, presented to him by the Gúrú of the family, whose duty it is to keep the Book of the Chronicles. I purpose to offer to the Society some observations on these papers.

The city of *Vijayanagar* was situated on the south side of the river *Tungabhadra*, (Toombuddra). On the north was the suburb of *Anagunds*, the Elephant city, which is still a town of some size, and gives its name to both the ancient and modern towns: they are also called *Alpaltan*. Of the city of *Vijayanagar* the only remains are the ruins of innumerable temples interspersed with jungle, and tenanted by baboons. The principal temples are to the west of the road along the bank of the river. One of them dedicated to VITALA, a form of VISHNU, is said to be equal in its architectural details to any thing to be seen at *Ellora*. The roof is formed of immense slabs of granite, supported by columns of the same material richly carved, between 20 and 30 feet high, and of a single block. Another temple approached by a long, broad and colonnaded street is that of *Pampapati Virapáksha*, which is kept in repair by the British Government. Other remarkable buildings of this class are the temples of VIRABHADRA, and of GANESA; near the latter of which is a statue of NARASINHA, 30 feet high. There are also the remains of the Raja's palace and elephant stables, and the granite piles of a bridge over the *Tungabhadra*.

*Vijayanagar* was known to the first travellers in India as *Bisnagar*, and the kingdom of NARSINGA, the name of one of the sovereigns, (*Narasinha*), being erroneously given to the country. ODOARDO BARBESSA, who published an account of his travels and a summary description of India in 1516, calls the king of *Narsinha*, RASYESNA, mistaking titles for a name. He describes the city as of great extent, highly populous, and the seat of an active and valuable commerce, especially in the diamonds of the country\*, pearls from the *Persian Gulf*, rubies from *Pegu*, silks and brocades from *China* and *Alexandria*, and broad cloths from the latter; quicksilver and cinnabar, opium, sandal, aloes, camphor from various quarters, musk and pepper from *Malabar*. The king, he adds, maintains about 900 elephants, 200 of which are always ready for war, as well as a force of 20,000 cavalry and an immense host of infantry; *Vijayanagar* being in constant hostility with the kings of *Dakhan*, the Muhammedan prince of *Bijapur* and the west, and the Hindu sovereign of *Orissa*. The palaces of the king and his courtiers, and the numerous temples are said to be stately buildings of stone, but the greater part of the population resided in hovels of mud and straw. The provinces forming the kingdom of NIRSINHA are called by BARBESSA, *Tuliman* (*Tuluwa*), *Canarini* (*Canara*) *Cormandel*, and two others of which the name or names *Trenlique* are evident errors of transcription: the provinces were probably *Telingana* and *Dravira*—so that in the commencement of the 16th century, the kingdom comprised the whole of the Peninsula south of the *Krishna*, inclusive of the Portuguese possessions and the petty principalities of *Malabar*.

There are various traditions current in the *Dakhan* respecting the foundation of the kingdom of *Vijayanagar*. According to one account, the celebrated scholar and statesman MĀDHAVA, surnamed VIDYARANYA, implying

---

\* Probably of the *Rourconda* mines, situated about 30 miles east of *Vijayanagar*, or north of the *Kistna*:—See TAVERNIER'S account of them. R.

his belonging to an order of Gosains, instituted by SANKARĀCHĀRYA, was directed by the goddess BHUVANESWARĪ to the discovery of a hidden treasure with which he built the city of *Vidyanagara*, or city of Learning, afterwards changed to *Vijayanagara*, or city of Victory. He reigned over it himself, and left the sovereignty to a family of the *Kurma* or *Kuruba*, or shepherd race. Another statement describes him as founding the city, and installing as king, BUKKA, a shepherd who had waited on him in his devotions. A third account states, that it was founded by BUKKA and HARIHARA, two fugitives from *Warankul*, after that was captured by the Muhammedans, who encountered the Sage in the forest, and were elevated by him to the sovereignty of the city which he built for them :—and the fourth statement, whilst it confirms the latter part of the history, makes BUKKA and HARIHARA officers of ALA-UD-DIN, who were detached after the conquest of *Warankul* against the *Belal* Raja of *Mysore*. They were defeated and fled into the woods where they met VIDYARANYA, who furnished them with money to raise a new force with which they gained a victory over the *Belal* prince, and by the advice and with the aid of the hermit established a new kingdom. These different traditions are so far consistent that they attribute the foundation of the kingdom to the same individuals BUKKA and HARIHARA, with the aid of VIDYARANYA, and there is no doubt that they were the main instruments in the elevation of the principality, and probably concerned in the foundation of the capital city, although we know from a less exceptionable source than tradition that the treasures of VIDYARANYA, the origin of BUKKA and HARIHARA, and their being the institutors of the kingdom, are embellishments originating in legendary fiction and popular credulity.

VIDYARANYA or MĀDHAVA ACHĀRYA is a well known personage in Hindu literature. A number of laborious works, illustrative of the theological philosophy of the Hindus, of their law and of grammar, are ascribed to him ; and voluminous comments on the *Vedas* and *Upnishads* are

attributed to his brother SAYANA ACHÁRYA. It is probable that MÁDHAVA was rather the patron than the author of many of the works that bear his name, a circumstance not uncommon in Hindu literature, but most of the works, of which he or his brother is the reputed writer, specify their names and characters, and describe MÁDHAVA as the minister of SANGAMA, the son of KAMPA, a prince whose power extended to the southern, eastern, and western seas, the limits in fact of *Vijayanagar*. The same passages shew that MÁDHAVA continued to be minister to the sons of SANGAMA, or BUKKA and HARIHARA, and this relation to their predecessor is confirmed by various inscriptions, as by one in the 9th volume of the Researches, and by the inscription No. 11 of the present collection. The power of SANGAMA may be exaggerated in the usual strain of Oriental flattery, but it is clear that he ruled over part of the territories of the south, perhaps as a feudatory, either of the *Kalyána* or *Belál* Rájas: and that upon the subversion of the former, and the decline of the latter, he, or perhaps his successors, acquired a degree of political power which may reasonably be regarded as the rudiment of the future kingdom of *Vijayanagar*.

The family pedigree furnished by Mr. RAVENSHAW, in a strain not peculiar to any age or country, deduce the royal dynasty from a lofty source—or from the moon through the family of PANDU, counting 86 descents from PANDU to NANDA, the son of the sovereign of *Bylemdis*, who was driven from his patrimonial possessions by foreign aggression, and settled in *Andhra* or *Telingána*, where he founded *Nandapurí* in the *Sáli-váhana* year, 956 or A.D. 1034. According to the genealogy, he subdued the whole of the Peninsula from the *Godáverí* to *Rámeswara*, an assertion wholly incompatible with the history of the other dynasties of Princes, as derived from local accounts and inscriptions. NANDA was succeeded by CHALIK RAYA of *Kalyán*, who had three sons, BIJAE, BIJAY RAYA of *Bijayanagar*, and VISHNUVERDDHANA, who had no principality. The direct line of *Vijayanagar* continued for four descents to BHUP RAYA, who dying in

*Sáliváhana* 1196, (A. D. 1274) and having no son, VIDYARANYA, the Gúru of a neighbouring Raja named JAMBUK RAYA, placed that Raja's son BUKKA RAYA on the throne of *Vijayanagar*.

We have here consequently an account different from all the preceding ; how far more trustworthy may be questioned ; at any rate it is inaccurate with respect to the name of the father of BUKKA, and with regard to his date, which we know from inscriptions was about A. D. 1370, or two centuries more modern than that in the given pedigree. Tradition places also the foundation of *Vijayanagar* in A. D. 1336, a period not incompatible with the political events to which it possibly owed its elevation, the capture of *Dwárasamudra* (the capital of the *Belál* kings of *Mysore*) by the Muhammedans, and consequent decline of their power occurring in 1310-11, and the destruction of *Warankul* and the subversion of the *Andhra* or *Telinga* monarchy by the same enemies taking place about 1323. The Muhammedans were prevented from following up their successes by the disturbances in Upper Hindustan, which followed the death of ALA-UD-DIN ; and the origin of the *Bhámíni* and other dynasties of the *Dakhan* : the interval which ensued, and the absence of any paramount sovereignty in the Peninsula were prohibitions to the rise and development of a new power in that quarter.

I have in another place animadverted upon the incongruity between the chronological lists of the *Vijayanagar* princes commonly current in the south of India, and the series of names and dates derivable from inscriptions ; the former specifying 27 princes from BUKKA to the 3rd SRIRANGA between A. D. 1327 and 1665 ; and a collection of a great number of the latter, distinguishing only 14 princes between A. D. 1370 and 1626. The pedigree gives 20 princes from BUKKA to the 3rd SRIRANGA between 1274 and the middle of the 17th century. A comparison of the three however will reconcile some of the seeming incongruities and afford a clue to others.

The three different lists are as follows :

<i>From Books.</i>	<i>Inscriptions.</i>	<i>Pedigree.</i>
1 Bukka, A.D. 1313 to 1327.	1 Bukka, ..... 1370 1381.	1 Bukka, ..... 1274 1386.
2 Harihara, ..... to 1341.	2 Harihara, ... 1385 1429.	2 Harihara, ..... 1367.
3 Vijaya, ..... 1354.	3 Deva Rája, 1428 1458.	3 Deva Rája, ... .. 1361.
4 Visvadeva, ..... 1362.	4 Mallikárjuna, 1451 1465.	4 Vijaya, ..... 1419.
5 Rámadeva, ..... 1369.	5 Virúpaksha, 1473 1479.	5 Pundradeva, ..... 1424.
6 Virúpaksha, ..... 1374.	6 Narasinha, 1487 1508.	6 Rámachandra, ... 1451.
7 Mallikarjuna, ..... 1381.	7 Krishna, ... 1508 1530.	7 Narasinha, ..... 1472.
8 Rámachandra, ... 1390.	8 Achyuta, ... 1530 1542.	8 Virúnarsinha, ..... 1490.
9 Sálavaganda, ..... 1397.	9 Sadasiva, ... 1542 1570.	9 Achyut.
10 Devaráya, ..... 1412.	10 Ráma Raja, 1547 1562.	10 Krishna, ..... 1524.
11 Kumbhaya, ..... 1417.	11 Trimala, ... 1560 1571.	11 Ráma, ..... 1564.
12 Kumára, ..... 1421.	12 Sriranga, ... 1574 1584.	12 Sriranga, ..... 1565.
13 Sáluvaganda, 2d, 1428.	13 Venkatapáti, 1587 1608.	13 Trimala.
14 Sáluva Narsinha, 1477.	14 Viraráma, ... 1622 1626.	14 Venkatapati.
15 Imjadi Deva, ... 1488.		15 Sriranga, 2d.
16 Viranarasinha, ... 1509.		16 Rámadeva.
17 Krishnadeva, ..... 1529.		17 Venkatapati.
18 Achyuta, ..... 1542.		18 Trimala.
19 Sadasiva, ..... 1564.		19 Rámádeva.
20 Trimala, ..... 1572.		20 Sriranga, 3d.
21 Sriranga, ..... 1586.		21 Venkatapati.
22 Venkatapati, ..... 1615.		
23 Sriranga, 2d, ..... 1628.		
24 Venkata, ..... 1636.		
25 Rámadeva, ..... 1643.		
26 Anagundi Venka- tapati, ..... 1655.		
27 Sriranga, 3d, ..... 1665.		

The inscriptions serve to correct both the traditional and the family chronology, and shew that they place the commencement of the series with BUKKA about 40 or 50 years too soon. He could not have reigned long after 1381, as his successor's grants date in 1385, and a long reign would therefore place his accession no earlier than the middle of the 14th century, or about 1346, the traditional date of the foundation of *Vijayanagar*. The traditional chronology, however, gives him a reign of only 14 years,

## TRANSLATION OF INSCRIPTIONS

in which case his grants commence almost with his reign. He could not therefore have founded *Vijayanagar*, if the date commonly assigned for that event is accurate ; and, at any rate, we need not correct that date by the years of BUKKA'S reign, as on other grounds noticed above, it is little to be doubted that BUKKA RÁYA was not the first sovereign of *Vijayanagar*.

All the accounts agree in representing BUKKA Rájá as an enterprising and successful prince, and as having widely extended the limits of his authority. Circumstances were favorable to his arms ; and, besides the propitious consequences of foreign invasion, it seems likely that the rise of BUKKA RÁYA was favoured by previous internal dissensions on the score of religion, and that his prosperity was founded upon a principle of toleration. His minister VIDYARANYA was a *Saiva* ; one of his generals IRUGUPU appears, from inscriptions, to have been a *Jain* ; and in a proclamation, published in the *Researches*, by the princes BUKKA and HARIHARA, they appear as mediators between the *Jains* and *Vaishnavas*, declaring that there is no difference between the two forms of faith.

In one of Mr. RAVENSHAW'S inscriptions BUKKA is succeeded by his son HARIHARA, having, it is also stated, a brother of that name. This seems likely from the space through which the grants of HARIHARA extend, viz. to A. D. 1429. If this were the brother alluded to in other inscriptions, and by MÁDHAVA, a *Sarorya*, we should have to assign him a reign of about 60 years. Even as the son he reigned a longer time than common, or between 40 and 50 years.

The 3d sovereign, in two of the lists, is DEVA RÁYA, with this peculiarity in the inscriptions that his grants begin three years before those of his predecessors terminate. This circumstance recurs in the succeeding reign, making it probable that the practice prevailed, which was common in the remote periods of Hindu history, of a monarch's associating with him



## FOUND AT VIJAYANAGAR.

towards the close of his reign, his son and successor as *Yuvarāja* or *Cæsar*. The traditional chronology makes DEVA RAYA the 4th, placing before him VIJAYA, who is not named in the inscriptions, and who in the pedigree follows DEVA RAYA.

The 5th prince of the chronology is RÁMADEVA, who is followed by VIRÚPAKSHA, and he by MALLIKÁRJUNA. The first does not appear in the inscriptions, nor the two last in the pedigree. In the inscriptions also MALLIKÁRJUNA precedes VIRÚPAKSHA; there can be little doubt, therefore that the order of the chronology is incorrect. The pedigree has, for the 5th prince, a PUNDAR DEVA, who is not found in either of the other authorities, and may be perhaps the same as MALLIKÁRJUNA or VIRÚPAKSHA. The name may possibly be intended for PRAURHA DEVA, a prince of whom many inscriptions are found from 1450 to 1466, and who is identified chronologically therefore with MALLIKÁRJUNA. There is nothing in the specification of dates that militates against the identity of MALLIKÁRJUNA, VIRÚPAKSHA, and PRAURHA DEVA, as the inscriptions of all three are confined between 1450 and 1479, in a period of 29 years.

The 8th prince of the chronology and 6th of the pedigree is RÁMACHANDRA, of whom no inscriptions have been yet found, and who is therefore of questionable existence. We have then a series of seven princes in the chronology; none, or at most but one of whom is traceable in the other authorities. Possibly the 14th or 15th, SÁLAVA, NARASINHA or IMMÁDI DEVA, may be the NARASA or NARASINHA of the pedigree, and of some of the inscriptions: the NARASINHA of which is no doubt the same as the VIRA NARASINHA of the pedigree and chronology, and who, as reigning about the end of the 15th and beginning of the 16th centuries, is the NARSINGA of the first European voyagers to India.

The exclusive occurrence of a series of princes in the traditional chronology may perhaps be accounted for by domestic dissensions, the

consequent decline of the power of the RAIS of *Vijayanagar*, and change of dynasty which it is admitted took place. The reigns are in general very short, and in the inscriptions we have two intervals of which one, that between the 5th and 6th prince, of 8 years, might be filled up by some of the names of the chronology : at any rate it is certain that with NARASINHA a new family ascended the throne.

According to FERISHTA, NARASA, or NARASINHA was a Raja of *Telingána*, who had possessed himself of the greater part of the *Vijayanagar* principality. This is not incompatible with the account given in the pedigree, which states that SRIRANGA RAYA, Raja of *Kalyán*, made war upon RAMCHANDRA of *Vijayanagar*, deposed him and placed his own brother on the *masnad*. Other accounts give a different version of the matter :—VIRŪPAKSHA, it is said, having no issue raised one of his slaves named SINHAMA, a *Telinga*, to the throne. SINHAMA, entitled PRAURHA DEVA, reigned but four years, he was succeeded by his son VĪRANARASINHA, who reigned but two years, who being childless gave his signet to his falconer NARASA or NARASINHA. Different original statements again concurring with that of FERISHTA represent NARASINHA as the son of ISWARA DEVA, Raja of *Karnul* and *Orviri*, a tract of country on the *Tungubhadra*, to the east of it near its junction with the *Krishna*.

According to the pedigree it must have been NARASINHA RAO, the only NARASINHA of the inscriptions, who was the monarch that gave a fresh impulse to the prosperity of *Vijayanagar*, and maintaining a resolute opposition to the Muhammedan kings of the *Dakhan* extended his authority over the greater part of the Peninsula and along the Coromandel Coast towards *Orissa*. On his death he left two sons VĪRANARASINHA and KRISHNADEVA, the latter of whom acted as Dewan to his brother. VĪRANARASINHA, according to the pedigree, left three sons, ACHYUTA, SADASIVA and TRIMALA, who being infants, the country was managed by their uncle KRISHNADEVA.

The truth appears however to be that not only were their claims set aside by their uncle, but that even in the life time of their father VĪRANARASINHA, KRISHNADEVA usurped the supreme authority and hence the doubtful occurrence of the name of the former in public documents from 1508 to 1530, the period assigned for the reign of KRISHNADEVA.

According to the *Krishna Rāya Cheritra*, KRISHNADEVA was the son of NARASINHA by a concubine NAGAMBES. His stepmother, the queen TIPAMBA, dreading what came to pass, the supplanting of her own son VIRASINHA, prevailed upon the king to order KRISHNADEVA to be put to death, but the prince was preserved and secreted by the minister. NARASINHA on his death-bed being informed of the preservation of his son, declared him his heir and successor, and the chief Poligars concurring in his nomination, the claims of VĪRANARASINHA were disregarded, and he died, it is said, of grief at his disappointment.

The dominion of *Vijayanagar* that had been partly recovered by NARASINHA was fully re-established by KRISHNADEVA. He defeated the *A'dil Shāhi* princes and extended his frontiers to the southern bank of the *Krishna*: he captured *Kondavir* and *Warankul* on the east, and marched as high as to *Cuttack*, where he wedded the daughter of the *Gajapati* sovereign. In the south, his officers governed *Srirangapatan* and *Kāmeswara*. On the west, his taking *Rachol* on *Salsette* is recorded by the Portuguese writers, and *Malabār* appears to have acknowledged his supremacy. At no period, probably, in the history of the south of India, did any of its political divisions equal in extent and power that of *Vijayanagar* under KRISHNARĀYA.

KRISHNARĀYA was also a patron of literature, and a number of learned men were received at his Court. Eight of these were known as the *Diggajas*, the elephants that support the regions of the atmosphere. They

were mostly celebrated as *Telugu* authors, but one of them *Assyaya Dikshita*, is a name of some note in Sanscrit composition.

From the general tenor of the inscriptions and from his coins, this prince was also a zealous patron of that form of the *Vaishnava* faith, which consists in the worship of KRISHNA and RÁMA. One of the inscriptions before the Society records his bringing an image of KRISHNA from *Udayagiri*, after the capture of that fortress, and erecting a temple for it at *Krishnapuran*, endowed with seven villages, and with other sources of revenue, the transit duties and profits of an adjoining reservoir.

After KRISHNARÁYA the pedigree observes, that RÁMA Raja his brother-in-law, or agreeably to other statements his son-in-law, contended for the *masnad*; but it is evident from the inscriptions that some interval must have elapsed before he gained his object, as ACHYUTARÁYA's grants date from 1530 to 1545, and those of RÁMA do not commence until 1547. It is also evident that he attained to supreme authority only as the minister of the second son of VÍRANARASINHA, SADÁSIVARÁYA, as the grants of the king and his minister run nearly parallel, those of the former extending from 1542 to 1570, whilst those of the latter are dated between 1547 and 1562. The prince was, in fact, a mere pageant, and in the important events of this period involving the dissolution of the State, the name of RÁMA appears in the writings of both Muhammedáns and Hindus as the sovereign of *Vijayanagar*.

The contests for the supreme sway, so briefly alluded to in the pedigree, are very obscurely narrated by native writers, especially with regard to the persons of ACHYUTA and SADASIVA. So far, therefore, the genealogy is of value as it determines their characters. According to the Hindu annalists, KRISHNARÁYA having no children of his own, and the nearest heir ACHYUTA being absent, he appointed SADÁSIVA Raja under the protection of RAMA

**Raja.** ACHYUTA, however, returning resumed his right, and on his death SADÁSIVA ascended under the tutelage of RÁMA. It is therefore probable that an attempt was made, in the first instance, to expel the elder brother and place the younger upon the throne, but that this was defeated and ACHYUTA retained, at least nominally, the possession of his dominions.

The transactions of the Court of *Vijayanagar* at this period afford a curious illustration of the difficulty of obtaining precise accounts of occurrences in the East. The compiler of the pedigree could perhaps furnish, if he chose, more satisfactory details, but it is not possible to gain a clear view of the circumstances of the case from other authorities, although, in addition to Hindu writers, we have the accounts of two persons who were cotemporaries and almost eye-witnesses of what they detail. These are FERISHTA and CÆSAR FREDERICK, the former residing at the Court of *Bejapur*, and the latter a resident at *Bisnagar* for six months, about a year after its having been plundered by the Muhammedans. The following are their accounts :

According to FERISHTA, RÁMARÁYA, the son-in-law of KRISHNARÁYA, succeeded to the supreme ministerial authority. On the death of the infant Raja he placed another minor of the same family on the throne, and committed the charge of the Raja's person to the care of his maternal uncle HOJI TRIMALARÁYA, whilst he administered the affairs of the Government himself. The Raja's uncle after a time conspired against RÁMA, and compelled him to resign his post and retire to his estates. TRIMALARÁYA next murdered his nephew and made himself king, and with the aid of IBRÁHIM A'DIL SHÁH maintained himself in his usurped authority. As soon, however, as his Muhammedan allies withdrew, he was attacked by the hostile party, who defeated him and besieged him in his palace in *Vijayanagar*, where, finding his affairs desperate, he destroyed himself.

We will next hear what CÆSAR FREDERICK writes ;—“ About 30 years before the defeat and death of the king of *Vijayanagar*, three brother tyrants had usurped the throne, keeping the rightful king as a prisoner, shewing him once a year to the people, and themselves exercising the royal authority. They had been officers in the service of the father of the king, and had seized the government upon his death, leaving his son an infant. The eldest was named RÁMARÁJA, and he sat upon the throne and was called king; the second was named TEMMARÁYA, who discharged the function of governor; the third, VENKATARÁYA, was the commander of the forces. The first and last disappeared after the fatal battle, and were never heard of more either living or dead.”

However these different accounts differ in detail, they agree in the essential features of the story, and shew that the usurpation which commenced with KRISHNARÁYA was continued by his kinsmen, and that the sons of VFRANARASINHA were like himself, mere pageants in the hands of their ministers and chiefs. Had not the European traveller asserted that TUMMU RAO returned to *Bisnagar* after the Muhammedan kings had pillaged and left it, and was actually the ruling sovereign at the time that CÆSAR FREDERICK remained there, we might have suspected that he was the HÁJI TUMUL of FERISHTA—who had veiled his own ambition by supporting ACHYUTA. This, however, could not have been the case, and we may be content with FERISHTA’S account of the transaction.

The reign of RÁMARÁJA was, however, fatal to the principality of *Vijayanagar*. After being on alternating terms of friendship and enmity with the Muhammedan princes of the *Dakhan*, and given asylum and aid to ALI A’DIL SHÁH of *Bijapur*, who had been even adopted as a son by the mother of the Raja, the kings of *Golconda*, *Bijapur*, *Daulatábád*, and *Berár*, alarmed at his power and offended by his arrogance, combined against him. A sanguinary battle was fought at *Talikota*, on the banks of

the *Krishna*, in which, after a doubtful conflict, the Raja was taken and his troops defeated. The Hindu accounts assert that the divisions of KUTTEBBHAT and NIZÁM SHÁH that had been defeated, and those of ALI A'DIL SHÁH and AMDAT-UL-MULK covered the retreat when the Hindus, giving themselves up to festivity, were surprised by the rallied forces of the enemy, and thus overthrown. FERISHTA admits that the wings of the Muhammedan army were thrown into disorder, and that some of the leaders despaired of the day when it was retrieved by the efforts of the centre under NIZÁM SHÁH, and by the capture of RÁMA Raja. CÆSAR FREDERICK states that the loss of the battle was owing to the treachery of two of the Raja's commanders who were Muhammedans, and who, in the heat of the action, turned upon the Hindu divisions. Both Muhammedan and Hindu accounts agree that RÁMA Raja was put to death immediately after the battle, according to the one by A'DIL SHÁH, according to the other by NIZÁM SHÁH.

After the action, the allied Sultáns marched to *Vijayanagar* and laid it waste, and then withdrew. The families of RÁMA and his brethren, with the captive King, made their escape, and after a whole year TEMONA RÁYA, the surviving brother returned to his capital and attempted its reorganization. The country was, however, in so much disorder, and the roads so infested with robbers, that he found the attempt hopeless, and in 1567, retired to *Pennaconda*, eight days' journey from *Vijayanagar*. Endowments in the name of the pageant king SADÁSIVA continued to be made until 1570, and the pedigree carries on his family to the extinction of the direct line. SRIRANGA, who it may be supposed was the son of SADÁSIVA, succeeded to his father. The 9th in descent from him, VENKATAPATI, fled before the Moghul arms to *Chandragiri*, where a branch of the descendants of RÁMA ruled. His successor, RÁMA RAO, recovered a considerable extent of country apparently about *Anajundi* and *Vijayanagar*, and the line continued for seven generations more to 1756, when TRIMAL RAO was dispossessed

of his raj by the arms of TIPU. The history of the *Vijayanagar* kings, as given in the family pedigree, thus concludes. On the capture of *Srirangapatam*, the country was divided between the Nizam and the Company; 1,500 Rupees per mensem were allowed by the Company to the Raja of *Bijanagar*, but he continued thenceforth subject to the Nizam, holding the town and some lands around *Anagundi*, (*Bijanagar*) the ancient capital, as a Jágír from the Nizam. In 1829-30, the infant Raja died, and there being no heir, the Jágír has lapsed to the Nizam's Government, and the pension of 1,500 Rupees per mensem to the Company.

---

P E D I G R E E  
OF THE  
K I N G S O F V I J A Y A N A G A R,

TRANSLATED BY  
MR. E. C. RAVENSHAW.

**THE FOLLOWING PEDIGREE** was given to me by the *Guru*, or Priest of the family, whose business it is to keep the Book of the Chronicles.

The early part of the genealogical tree is merely an extract from the *Chandravansa* line of the *Puránas*, with considerable misplacements and inaccuracies. It commences with PANDU, from whom the *Vijayanagar* princes consider themselves descended.

PANDU RAYA, King of *Hastinapur*, was cotemporary with KRISHNA, King of *Mathura*, at the end of *Dwápar Yuga*. The list contains 122 generations, or rather reigns; and, if we divide 4929 by this number, it does not give more than 40 years for each reign, which is moderate for an Eastern Chronicle\*.

---

\* Chronologists, however, allow about 20 years to a generation, hence  $122 \times 20 = 2440 = 609$  B. C., which is probably a nearer approximation to the truth.



The descent of PANDU is traced in the list from BUDDHA, (MERCURY) the son of the Moon: he had a brother named DRITARASHTRA. I have omitted the names previous to PANDU, as well as the enumeration of his other three sons, (DHARMA RAJA BHIMSEN, NAKUL and SAHADEVA,) and confined myself to the line of ARJUN, and PARIKSHIT, to save space.

- |   |                         |                        |
|---|-------------------------|------------------------|
| 1. PANDU had five sons, called the Panch Pandava. | 28. Vihinukar.          | 57. Punamá.            |
| 2. ARJUNA, son of Indra, regent of the east.      | 29. Dhandáni.           | 58. Lambodara.         |
| 3. Abhimanyu.                                     | 30. Nimi.               | 59. Ballikar.          |
| 4. Parikshita, 3100 B. C.                         | 31. Chuma, 2100 B. C.   | 60. Méda.              |
| 5. Janamejaya.                                    | 32. Vrihadratha, 2d.    | 61. Sevati.            |
| 6. Shatánika.                                     | 33. Puranjaya.          | 62. Dhundhumara.       |
| 7. Sahasranika.                                   | 34. Shisunága.          | 63. Arishtakarma.      |
| 8. Aswimedhaja.                                   | 35. Shurunga.           | 64. Baléya.            |
| 9. Avishana Krishna.                              | 36. Kainvarma.          | 65. Trinama.           |
| 10. Chakri Rája.                                  | 37. Xemadharma.         | 66. Rushutoru.         |
| 11. Chittra Ratha.                                | 38. Sutchayitra.        | 67. Sunanda.           |
| 12. Babu Ratha.                                   | 39. Vidisára.           | 68. Vrinka.            |
| 13. Vishnumána.                                   | 40. Bayika.             | 69. Chechakára.        |
| 14. Shushayana.                                   | 41. Wajineya. (Ajaya ?) | 70. Viváshiti.         |
| 15. Sunichi.                                      | 42. Nandivardhana.      | 71. Aridamna.          |
| 16. Ruchita.                                      | 43. Mahánandí.          | 72. Gomati.            |
| 17. Nalla.  | 44. Shisunága.          | 73. Purína.            |
| 18. Pariplava.                                    | 45. Shujaya.            | 74. Swéta.             |
| 19. Mádhavi.                                      | 46. Vasu.               | 75. Utashétha.         |
| 20. Sunichi, 2d.                                  | 47. Bhadráka.           | 76. Kanva.             |
| 21. Ripunjaya.                                    | 48. Pulinda.            | 77. Yagashēt.          |
| 22. Durbi.  | 49. Gosha.              | 78. Vijaya.            |
| 23. Ninuga Rája.                                  | 50. Panchamitra.        | 79. Chandrabja.        |
| 24. Vrihadratha.                                  | 51. Angawána.           | 80. Marru.             |
| 25. Sorasi.                                       | 52. Devabhúmi.          | 81. Nanda.             |
| 26. Satanika Rája.                                | 53. Bhumimitra.         | 82. Bhutanandi.        |
| 27. Durdamana.                                    | 54. Naráyana.           | 83. Nandili, two sons. |
|   | 55. Krishna.            | 84. Séshunandi. }      |
|   | 56. Shantanu.           | 85. Yeshunandi. }      |

The last prince had fourteen sons who ruled over *Bylemðsh* (?) Two chiefs AMITRA and DURMITRA invaded them. The war was of considerable duration, and terminated in favor of the Invaders, who took possession of the country—seven of the fourteen sons fled to *Andhradésa* (or *Telingána*).

## 86. NANDA MAHÁRÁJA,

the eldest of the seven, built the village of *Nandapura*\*, and gave it as an *Agrahaj* (an endowment) to 500 Brahmans. His dominions extended from *Ráméshvara* to the *Godavery*—NANDA MAHARAJA after a reign of 42 years died in 998, *Saliváhana Saca*, in the year *Anala*, of the *Vrihaspati* cycle, (A. D. 1076.) he was succeeded by his son.

## † 87. CHALIK RAJA,

who reigned 41 years—i. e. to *Saca*, 1039-40. He had three sons,

VIJALA RAYA Reigned at <i>Kalyan Dharja Patán</i> , † 1041 <i>Saca</i> .  (after two generations had passed, SRI RANGA RAJA being king of <i>Kalyánpatan</i> , made war upon RAMCHANDRA, and deposing him placed his own brother, NARSINHA RAJA, on the <i>masnad</i> of <i>Vijayanagar</i> . (see below, no. 99.)  having no sons, VIDYARANYA, the <i>Guru</i> of a neighbouring Raja, named JAMBUK RAYA, placed BUKKA RAYA, son of the latter on the <i>masnad</i> , in accordance with the Law of <i>Kála,mádhavi,-grantha</i> . His sovereignty extended over the whole of the <i>Dakhan</i> .	88. VIJAYA RAYA at <i>Kiskindhanagar</i> or <i>Vijayanagar</i> , ..... an. <i>Saca</i> . 1039-40 A. D. 1118 89. VIMALA RAO, his son, ..... 1080      1158 90. NARSINHA DEVA, ..... 1104      1182 91. RÁMA DEVA, ..... 1171      1249 92. BHUP RAYA, ..... 1196      1274  93. BUKKA RAYA, ..... 1256      1334 94. HARIHARA RAO, ..... 1289      1367 95. DEVA RAO, ..... 1313      1391 96. VIJAYA RAO, ..... 1336      1414 97. PUNDARA DEVA RAO, .... 1346      1424 98. RAMCHANDRA RAO, ..... 1372      1450 99. NARSINHA RAJA, ..... 1395      1473 100. VIRA NARSINHA RAJA,.... 1412      1490	and VISHNUWARDHAN had no kingdom.
---	---	---

had three sons—ACHITA RAO, SADASHEO RAO, and TRIMALA RAO; but these being children at the time of the death of their father, the country was managed by KRISHNA RAO, their uncle, who had been the *dewan* of their father.

## 101. ACHITA RAO.

## 102. KRISHNA DEVA MAHA RAYA, 1446      1524

Extended his dominions over *Anandashen*, or *Mahánad* (near *Ramnad*), *Kunchy* (eight *koss* from *Arcot*), *Pandu Desh* (about *Madura*), *Choldesh* (*Tanjore*) and *Sri-Ranga* (near *Trichinopoly*), *Dudur Desh* (not recognized), *Arcot*, *Nellore*, *Srirangpatan* and *Mysore*, *Ahmednagar*, *Sonda* (*Bindunoor*), *Chittledrúg*, *Harpanhally*, *Jarriwakrattan*, *Girpaingora*, (*Pughur*), *Karpah* (*Cuddapah*) *Yadogiri*, *Raechore—Múdgai—Godwall—Karnul—Shorapur—Sagger—Pupdeymal—Kaliándrug*, *Kalbarga—Golconda—Amdanagar* (*Guzerat*), *Yankatgiri—Purinda*

\* Perhaps, also *Warangol*, the ancient capital of *Telingána*, whence the *Vijayanagar* family are said by GRANT DUFF to derive their origin.

† Here the numbers cease in the original MS.

‡ *Kalian Drúg*.

and *Rámgerh*—(then follows a list of *jágirs* granted by KRISHNA DEVA to the members of the royal family and others.)

## 103. RAMA RAJA,

KISHEN RAO's brother-in-law, contended for the *masnad*; after which the Musulmans under NIZAM SHAH invaded the country : after him again IMAD UL MULK, opposed and killed RÁMARAJA in *Saca*, 1486, 974 *Fasli* A. D. 1564.

KARMA RAJA, .....	}	his sons.
TRIMALA RAJA, .....		
KISHEN BHUPATI, .....		
CHUKTAN RAJA, .....		

104. SRI RANGA RAJA, *An. Saca*. 1487 A. D. 1565

his brother TIMA RAJA was *dewan*—his sons were YANGATPATI and CHINGANKATAPATI.

## 105. TRIMALA RAJA, son of CHINGANKATAPATI.

## 106. VIRA YANGATPATI.

## 107. SRI RANGA RAJA.

## 108. RÁMADEVA RAO.

## 109. VENKATAPATI RAO.

## 110. TRIMALA RAO.

## 111. RÁMADEVA RAO.

## 112. SRI RANGA RAO.

## 113. VENKATAPATI

invaded by the Moghuls and fled to *Chandragerhí*.

## 114 RÁMA RAO

dispossessed the Moghuls of an extent of country yielding 5 lakhs per annum.

115. HARI DÁS, .....	1615	1693
----------------------	------	------

116. CHAK DÁS, (his brother).....	1626	1704
-----------------------------------	------	------

117. CHIMA DÁS, .....	1643	1721
-----------------------	------	------

118. RÁMA RAYA, .....	1656	1734
-----------------------	------	------

119. GOPÁL RAO, son of CHAK DÁS.		
----------------------------------	--	--

120. YANKATAPATI, .....	1663	1741
-------------------------	------	------

121. TRIMALA RAO, .....	1678	1756
-------------------------	------	------

SULTÁN KHÁN—possessed himself of the country in the name of TIPU. It was afterwards retaken by TRIMALA RAO. On the capture of *Siringapatam*, the country was divided between the Nizam and the Company—1500 Rs. per mensem were allowed by the Company to the Rája of *Vijayanagar*,

122. VIRA VENKATAPATI RÁMA RAYÁ, a minor; but he continued thenceforth subject to the Nizam, holding the town and some lands around *Anagundy*, (*Vijayanagar*) the ancient capital, as a *jágir* from the Nizam. On the 31st May, 1829, the infant Rája died, and there being no heir, the *jágir*, I understand, has lapsed to the Nizam's Government, and the pension of 1500 Rs. per mensem to the Company.

*TRANSLATIONS OF THE INSCRIPTIONS.*

FIRST INSCRIPTION

*On the Flag Staff, called Dhajastambha, which is on the East side of the Temple of Jaina-guri, in the Road of Anagundí.*

---

**SALUTATION** to the dust of the feet of the sand of JINA DEVA, which gives knowledge to the ignorant, and dispels the darkness of our hearts. May JINA DEVA be favorable !

The emblem (or flag-staff) of JINA DEVA, who is the lord of the three worlds, who is the happiest, the most graceful in form and splendid in appearance.

In the place called *Nandisangam*, near a large and beautiful *Tamary* (lotus) pond, called *Saraswatí* (or goddess of learning) was born PADMANANDÍ, as the lotus springs from the tank. He had five names called CUNDAPADA, BAKRA DEVA, MAHÁ MATÍ, ILACHARYA and GANDHAPINCHHA. In his race some of the noblest of the *Munis*, or priests, were born like gems from the ocean.

Of the same race a priest called RATNAKARA GURU, the beautiful and good, was distinguished by the name of DHARMABHUSHANA YOGENDRA BHATTARAKA, which signifies the ornament of charity. The sky inhaled the fragrance of the fame of this priest DHARMA BHATTARAKA, as the black beetle when he runs over the flowers. The sky was smaller than his fame: if you ask an explanation of this enigma, the answer is, as the elephant beholds the whole of his body in a small looking glass.

To the devout DHARMA BHATTARAKA was born a son called AMARAKIRTI.

Adoration be to the *Muneswara* or priest AMARAKIRTI, who enlightens our darkness with the light of *Vidyá* or instruction. Of what use were men of learning when AMARAKIRTI existed? From him was born SIMÁNANDI. From the priest SIMÁNANDI descended the charitable and fortunate DHARMABHUSHANA, a pillar of the temple of charity, who was called *Dharmabhattáraca*, and whose fame was resplendent as the full moon in her glory.

From DHARMABHUSHANA, a *Muneswara* called DUNDAMANNA was born, who was as the black beetle to the lotus-feet of SIMMANUNDI.

From the priest DANDAMÁNA was born BHATTARAKA, *Muni*, who was fortunate and famous like DHARMABHUSHANA. Worship be unto the feet of DHARMA-BHUSHANA, in whose presence all the kings of earth bow down !

Of the race of BHATTARAKA\* *Muni* was born *Yánti Rája* a great and happy king, BUKKA.† From him descended HARIHARESVARA,‡ who illuminated the world with all the arts and sciences, as the beams of the moon illuminated the milky sea. While ruling his kingdom, conquering many kings, and extending his dominions, he was called *Rajanvati*, because he was the greatest legislator the world ever beheld. While ruling the earth, whose girdle is the four seas, the glory of his ancestors was dimmed by his superior light. He had a minister named CHAICHADANDA the naik, who was skilled in the transaction of private and public affairs, was warlike as CUMARESWAMI in battle, and devoted to the king; who was styled *Bhubhat*, or husband of the earth.

To CHAICHADANDA the naik, was born a son called IRUGADANDA, who was blessed, celebrated, saluted, and adored in the world.

IRUGADANDA, who was a black beetle to the lotus-petaled feet of the priest SIMÁNANDI (the image of VISHNU, SIVA, and HIRANYAGARBHA§), in the year of the fortunate *Sáliváhana* 1307, corresponding to the year *Crodhana*, in the month of *Phalguna* *Crishna* *paksha*, *dویتیا* *Sukravára*, or, Friday the 18th of the moon in the month of March, (A. D. 1385,) built and erected the flag staff with black stone in the street, where the girls played in the water like a stream poured forth by *Kuntala*, and the mound on which the flag staff stands, was prepared with pearl-like sand in the extensive city of *Vijayanagar*, which abounds with nine sorts of precious stones, and which is situated in the country called *Carnatic*.

---

## SECOND INSCRIPTION.

*A Bond of Donation, written in Sánscrita verse on a Temple in the Village of Krishnapuram.*

ADORATION to PARAMESWARA on whose brows rest the *Chámaras* and the moon, and who existed before the three worlds!

Homage to the fortunate KRISHNASWÁMI, who is exalted as the clouds, who alleviates the sorrows and pardons the sins of his servants, who is a friend to the earth,

---

\* Perhaps VIDYARANYA.

† According to the Pedigree, the father of BUKKA RAYA was a neighbouring Raja named JAMBUK RAYA.

‡ HARIHAR RAE.

§ BRAHMA.

and who stole the butter of the churned ocean. There was a man who was given as a gift to the *Bráhmans*, who bestowed on them his weight in gold that they might travel to all principal pagodas and bathe in the holy waters of *Cánchi*, *Srisaila*, *Sonáchala*, *Kanakasabha* and *Venkataparbat*, who punished kings for their transgressions, who was the ablest warrior in the fight, the greatest amongst the kings of the earth, who was called *Paramésvara*, or a governor of governors, who was supreme lord over the three kings\*. He slew HINDU RÁYA, named the tiger. He was called *Ganda Bhérunda†* or the elephant. All the kings blessed him, and prayed that he might live long to be the first among those who dwell in the dominions of *Anga*, *Vanga*, *Calinga*, &c. He was benevolent, bestowing alms to the poor. He was a man formed to sit on the precious throne, and to govern the earth, he was called the fortunate KRISHNA RÁYA of many titles, who dwelled at *Vijayanagar*, and the light of whose fame for charity and beneficence shone resplendent from the mountain called *Udaya*, to the mountain called *Astamána Parbata*, or in other words, from the rising to the setting sun, and from the north to the south, or from the beginning of the mountain *Merú* to the south sea. The said KRISHNADEVA MAHÁ RÁYA sitting on the precious throne, after conquering the king of *Udayagiri*, and bringing away (the image of) KRISHNASWÁMI, returned to his city and installed it in the *Mantápam*, a building inlaid with emeralds, in the 1436th year of *Sáliváhana*, in the month *Phálguna*, *Sukla Pacsha*, *Tritiya*, *Sukravára*, or on Friday the third day of the moon in the month of March, A. D. 1514.

---

### THIRD INSCRIPTION.

---

**SALUTATION** to the dust of the sand of the feet of JINA, which removes the ignorance and the darkness of our hearts!

The bond of inscription of JINA, who is the Lord of the three worlds, who is the happiest, the most beautiful, the most splendid!

There was a country called *Carnáta*, beautiful as heaven, which resembled the dwelling of the deities, who feasted on the substance called *Ambrosia*, and quaffed the drink called *Nectar*.

In this same *Carnáta*, there was a city called *Vijayanagar*, which was the chief amongst the cities, and which was beautiful to behold, being adorned with magnificent

---

\* See the 9th Inscription.

† See the 7th Inscription.

palaces, and lofty houses which appeared overlaid with gold, like the mountains of *Merú* and *Kailás* lifting their golden heads to the sky. As the earth encompassed by the girdle of the four seas is illuminated by the flaming fire called *Bádabánala* (or *Aurora Boreális*), so the city, arising from the water of the moat, is resplendent with gold and silver, and radiant with surpassing brightness. At this time reigned the king called **BUKKA**, who was the lord of the city, and had immense riches. He was a gem of the race of **YADU**, a shining precious stone in a crown of jewels. His beauty resembled that of **KRISHNA**; he was equal to **RÁMA** in symmetry of form, in wit, in courage, and in beauty. He conquered by his valour all the quarters of the world, and was to the kings who were his enemies what the moon is to the lotus.\*

From him descended a king called **HARIHARAKUMAPATI**,† who shone in the world as the sun in the sky, who was the best pilot to the vessel in the sea of poverty, who was liberal as **PARASURÁMA** in presenting lands; who was as **CARNA**‡ in giving away gold; who planted the flag-staff of victory on the shores of the four seas, and whose fame was spread as far as the rays of the full moon.

From him a king called the fortunate **DEVARAJESWARA**§ was born, whose feet were like the lotus petals, and when the kings who were his enemies prostrated themselves before him, the jewels in their crown reflected the radiance of his feet. He was to the learned as the moon to the lily flowers. Among the brave he was the bravest. Among the happy the most happy.

From him a king called **VIJAYA**|| **NARAPATI** arose, the benefactor of mankind, and beneficent in charitable gifts, who extinguished the light of the glory of brave kings with the wind of his victorious banners.

**VIJAYA NARAPATI** had a son named **VĪRADEVA RAYA**¶ to whom he was attached like the full moon to the sea, or as **INDRA** to his son **JAYANTA**. He was skilled in depriving hostile kings of the five elements called life, with the sword called the poisonous serpent. The fortunate **DEVA RAYA** was a friend to pardon, and consoled the kings who submitted to him, but broke the clouds of hostile princes in pieces, with the wind of the ears of the elephants in the day of battle.

\* The lotus hangs its head and closes its leaves at night, whence the moon is said to subdue it.

† Quere **HARIHARA RAO**, 94 of Pedigree.

‡ The son of **KUNTI**, the wife of **PANDU**, king of *Hastinapur*.

§ **DEVA RAO**, Pedigree 95 ? || **VIJAYA RAO**, Pedigree 96. ¶ **PUNDARA DEVA RAYA**, Pedigree 97.

In the army of the fortunate DEVA RAYA, the dust of the sand of the earth which arose from the feet of the horses resembled the smoke of the fire of the bravery of DEVA RAYA, who appeared as the luminous sun dispelling the darkness of the anger of the troops of the opposing kings, the tears of whose wives allayed the dust of the conflict.

The mouth of the lotus of the fame of DEVA RAYA was opened by the genial warmth of the sun of his valour. The sides of the world were the petals of the flower compared with which the golden mountains of *Himàchala* appeared like *Karnicá* (seats) and the *Diggajas* (or eight elephants) like beetles. The waters of the ocean formed the honey of the flower, and in its cup abode VIJAYA LAXMI, the goddess of victory.

While this fortunate king ruled the world the *Chintya Mani*, or wishing precious stone, was unsought for, and the *Calpa Vrixa*, or wishing tree, was unthought of by any one.

DEVA RAYA ruled over his kingdom with KIRTI, SARASWATI and BHU LAXMI, that is, the goddess of fame, the goddess of learning, and the goddess of the earth, which was created in form of an egg by the four headed god BRAHMÁ.

VAMANA, the fifth incarnation of VISHNU, would not have begged alms of BALI, had DEVA RAYA been living. The full moon would lose the brightness of her countenance when he gazed on her. From his touch the sinner became purified, and ceased to sin; and INDRA would not dare to cut the wings of the mountains in his presence for fear of his wrath.

The king DEVA RAYA, whose handsome face and person were like *Madanamanochara*, the Magnet which irresistibly attracts the hearts of women, was king of kings, a supreme governor, whose titles illuminated the world.

The happy DEVA RAYA resembled the king BUKKA in wisdom, HARIHARESVARA in benevolence, and VIJAYA BHUPATI in valour. He was well skilled in the arts and sciences, and was like an emerald from the mountain of *Rohanáchal*. His throne shed happiness on the earth: (repetition) king of kings, governor of governors, &c.

The king *Abhinava* (or new) DEVA RAYA, while he was reigning in the centre of the Carnatic country in the city called *Vijayanagar*, in the year *Parábhava*, 1348 *Saka* on the full moon of *Cartica* or December, A. D. 1526, erected in the betlenut-market, a temple glittering with gold and diamonds like the starry heavens, and therein he established the god PARSVANÁTH, who was worshipped, praised, and celebrated by INDRA, who was the moon to the lotus of falsehood, and who was the lion to the elephant of the eighteen principal sins. His fame and charity will endure until the sun and moon shall disappear from the firmament.



## FOURTH INSCRIPTION.

*On a Stone Pillar opposite to the Tower, called Ranga Mandapam, which is contiguous to Virupaksha.*

**MAY** prosperity and fortune prevail! Glory be to **SAMBHU**, who is the lord and chief pillar of the foundation of the three worlds, called the three *Nagaras*, whose head is circled with *Chàmaras* and adorned with the full moon!

May the glory, brightness, and splendour of **RUDRA** set us free from the bondage of ignorance!

**CHANDRA RÁYA** was born to enlighten the world as the moon arises in the sky to illumine the darkness of night, and as the butter came out from the milky ocean at the time of its churning.

He had a son called **BUDDHA**, who was as wise as Mercury, who had a son called **PURURAVA Chakravarti**, who had a son **ÁWU**, whose son was **NAHUSHA**, who had a son **YAYATI**, who had a son **TURVASU**. In the same line descended the king called **BUKKA**, who was conspicuous among sovereigns as the precious stone on the brow of kings. **KRISHNA**, the son of **DEVAKI** in his 5th incarnation *Vàmana*, or the *Dwarf*, sought alms from **BALI**, but king **BUKKA** far surpassed **BALI** in dominion, glory, and charity. His fame extended from the rising of the sun to the going down thereof, and from the mountain called *Himáchal* to the sea. From him a king was born, called **NARASA AVANPÁL**,\* as **PRADUMNA** was born from **KRISHNA**, the son of **DEVAKI**. He planted a flag staff at *Strirangam* in the middle of the river *Cavéri*, and slew the king of the country. He conquered the kings named **CHOLA RAJA**, **PURANDAR RAJA**† and **GAJAPATI**‡ who were all great warriors. He obtained a great name from the river *Ganga* to the city of *Lancaş*. He protected all the knigs, who were at peace with him from the sun rising mountain called *Udaya Parvata* to the setting place called *Astagiri*.

In all the holy places named *Râmeswara*, &c. he distributed charities. He had a son called **VÍRANARASINHA KRISHNA DEVA MAHÁ RÁYA**, born from the princess named **NAGALÁ** as **RÁMA** and **LAXMANA** sprung from **CAUSALLIÁ**, and **SUMITRÁ** by **DASARATHA**: **VÍRA NARASINHA KRISHNA DEVA RÁYA** sitting on the throne embellished with nine sorts of precious stones, reigned over the world from the south sea to the

\* **NARASINHA RAYA**, (P. 99). † The Rájah of Madura? ‡ The Rájah of Orissa. § Ceylon.

north mountain *Meru*, his fame extended over the earth far wider than that of the sovereigns *NRIGA*, *NALA*, *NAHUSHA*. He distributed all kinds of charities in many holy places, viz. *Virupaksha*, *Calchartri*, *Vencatachelam*, *Carchi*, *Srisailam* in the mountain called *Sonasailam* and at *Pryága*, where the river *Ganga* and *Yamuna* (*Jumna*) join in one stream, *Srirangam*, *Cumbha Conam*, and in the holy water *Gocarnam* and *Ráma Sétu*, &c. When *NARASINHA DEVA RÁYA* having ruled the world with justice departed this life, *KRISHNA DEVA MAHÁ RÁYA* succeeded him. He was taken under the special protection of *SIVA*, who opened his third eye, which is situated in the middle of his forehead, to watch over him; also of *VISHNU* the four handed, who holds the circle called *Chakram* in one hand, and the shell called *Panchajanyam* in another; of *BRAHMÁ*, the four-headed, of *PÁRVATI*, the spouse of *SIVA* who holds a dagger in her hand; of *LAKSHMI* distinguished by the lotus, and of *SARASWATI*, whose harp denotes her to be the wife of *BRAHMÁ*. *KRISHNA DEVA RAYA* also performed the sixteen kinds of principal charities, named *Shadasa Mahádán*, in all holy places, waters, &c. Here follow a dozen lines enumerating his virtues, learning, and accomplishments, which are said to have equalled those of the *Rájas NRUGA*, *NALA*, *NAHUSHA*, *NABHAGA*, *DHUNDUMARA*, *MANDHATA*, *BHAGIRATHA*, *RÁMA*, &c. The said *KRISHNA DEVA RÁYA*, who was the son of *NAGAMBÁ*, and *NARA BHUPAL*, and who reigned over the world, sitting on the throne embellished with nine sorts of precious stones, at *Vijayanagar*, presented the village of *Singanahalli* (the boundaries of which are marked on four sides with black stones) for the purpose of furnishing the holy offerings, &c., to the Divine *VIRUPAKSHA*, whose temple is exalted as the mountains.

Be it known unto all persons by this inscription of *KRISHNA DEVA MAHA RAYA*.

---

#### FIFTH AND FIFTEENTH INSCRIPTIONS.

*A Bond of Donation to RAGUNÁTHA DEVA at the Panugonda Gate, on the West side of the Temple of Sunnapah, (in the Canarese language.)*

**MAY** prosperity and fortune endure!

In the year of *Sáliváhana* 1463, corresponding to the year *Sarvari*, in the month of *Kártika Sudipanchami*, *Guruvár*, (or Thursday the 5th day of the moon, in the month of December, in the year of our Lord 1545,) the fortunate, the great king of kings,

*Paramésvara*, the heroic, and famous, and glorious and valiant ACHYUTA\* DEVA MAHÁ RÁYA was reigning in the city of *Vijayanagar*, and sitting on the precious throne, when TIMMARÁGU, the son of UREGAE PEDDA AMBARÁGU of the tribe of CASYAPA, and in the rule of APASTAMBA, built a city called *Devaranjanam Patnam* on the east side of the *Panugondo Gháti*, and established RAHUNATH DEVA, as the tutelary deity thereof, bestowing the undermentioned lands to the god as an holy offering.

In the village called *Nalala Hunesa*, as *Sarvemánya Aggrahar* (or a gift of donation) we bought two *Vartí*, or two pieces of "limited" lands, from MUMIDI DILCHAT; who procured them by making the burning sacrifice, &c.

The particulars of the two lands are as follows:—

One place called *Pánchaca Stallam* of *Cottonwar* (below the canal) is of an extent sufficient for six *túms* of seeds. One place called *Congallu*, sufficient for four tooms of seeds. One place called *Chákala Vári Kunda*, or washerman's pond, named *Mula Maddy*, equivalent to four *túms* of seeds. One place is called *Virama Panchaka Stallam*, equal to seven *túms* of seeds. These four places we presented to the god RAGUNTHA DEVA for an offering.

Besides these, the *Mániems* given to the god RAGUNÁTHA DEVA for providing the daily offerings, were as follows:—

*Calasápuram Máganny* or in the village *Dévatápuram* below the old canal, a place called *Joghini*, which was cultivated by SANABHOGA VERUPARSA, equal to six *túms* of seeds. In *Campelly*, *Ariti Tola* or a plantain garden of SATTÁ SERUMIAN, equal to three *túms* of seeds. A place attached to *Singana Goda*, which is below the lake in *Dharmaságaram*, equal to three *túms* of seeds. In the village *Vadda Besavapuram*, a place called *Higgadiah*, which is near to the *Maniem* of *Sanabhoga Hinnarasiah*, which is equal to three *túms* of seeds. A place called *Elleguntah*, which also is equal to three *túms* of seeds. In the last two lands there are six *túms* of seeds. A place called *Ambelega Hindunnah*, which is near the bazar of *Cummarsa Naidu* in the village *Crishnapuram*, the land contains two half *túms* of seeds. A piece of land of *Pula Siddiah*, which is below the lake in the village *Camalápuram*, in which are three *túms* of seeds. A piece of land *Myan Hamiah Mallia*,† which is within the lake called *Vutacalva* in the village of *Madellapuram*, equal to half a *túm* of seeds. A piece of land called *Tumbená* belonging to GUDU MALLIAH, which is below the lake in the village *A'nantapuram*, in which are three *túms* of seeds. A piece of land called *Jaghena*,

\* ACHITA RAO of the Pedigree.

† Perhaps a part of the dry bed of the artificial lake.

which is cultivated by KANA MALLIAH, in which are four *túms* of seeds. In these two villages there is land equal to seven *túms* of seeds.

These eight villages were presented by us as *Maniem*, or as a gift. The seeds thereof were two *candies* and one half *túm*, and the two *vartís*, with the cocoanut trees in the village. *Nalala*, *Hunesa*, which we purchased, are in addition; the seeds of which were two *candies*. Those who unite together in continuing this charity will be rewarded a thousand fold. He who withholds or diminishes the charity will fall into the principal hell, and be guilty of a sin of the same magnitude as if he had murdered his mother and father at *Cási* (*Benares*), near the shore of the Ganges.

---



---

SEVENTH INSCRIPTION.

*A Bond of Donation written on the Wall, in the Temple of Hazár Rámaswámi.*

**MAY** virtue, fortune and victory prevail!

In the year of *Sáliváhana* 1442, corresponding to the *Vrihaspati* year *Vikrama*, in *Mágha Sudi Saptamí*, TIMMARÁZU, the son of CHAKKA\* DEVA MAHÁ RÁYA, of the tribe of *Casyapa*, the noblest of men, strong as the *Garuda Bharunda†*, and whose dwelling was in the heart of SARASWATI, (the goddess of learning) repaired the lake granted by KRISHNA MAHÁ RÁYA, and also presented the adjoining lands, on *Rádhá-saptamí* the 7th of the moon, (in the month of March, 1520,) to RÁMASWÁMI for offerings at the festivals, &c. in order to obtain salvation for his father and mother, &c.

---



---

EIGHTH INSCRIPTION.

*A Bond of Donation on a Stone called Vorí, in the Temple of Vithala Déva.*

**FORTUNE** and victory!

In the year of *Sáliváhana* 1483, corresponding to the year *Durmatí*, in *Chaitra Sudi Panchamí*, *Sanivár*, or on the 5th of the moon (in the month of April, 1561,) while the king

---

\* *Quere* CHAK DAS, 116 of Pedigree, TIMMARÁZU is not mentioned in the Pedigree.

† A fabulous bird with two heads, supposed to be able to lift up elephants in its talons.

of kings, *Parameswara*, the fortunate, famous and heroic SADASIVA\* MAHÁ RÁYA was reigning at *Vijayanagar*, CONATI CONDIA RÁJA DEVA MAHÁ RÁYA, the son of COTIA DEVA MAHÁ RÁYA of the tribe of *Casyapa* presented his village, lands, &c., as an offering to VITHALA DEVA in the season of *Makara, Sancranti Puniakál*, i. e. when the sun entered the eleventh sign of the Zodiac.

---

NINTH INSCRIPTION,

*On the Statue of the God NARASINHA DEVA in the Village Krishnapuram.*

---

IN the reign of *Sáliváhana* 451,† corresponding to the year *Virodhi*, in *Vaisákha Sudi Purnimá*, (or on the 15th of the moon in the month of May, 1539.)

The fortunate, the great king of kings, *Parameswara*, the famous and heroic KRISHNA RÁYA MAHÁ RÁYA the sage, the poet, the hero, the chief of three RÁMAS named NARAPATI, (Raja of *Vijayanagar*), GAJAPATI‡, and ASWAPATI§ established the god NARASINHA DEVA by the hands of a great man, named KRISHNA BHAKTI, in the village called *Krishnapuram*, which with other villages were presented as an offering to the deity.

*Detail of Villages.*

One village called *Vuravoconda Tosacáram Kitachinta*, near the country called *Udi*. One village called *Vanganur*, which is in the same country. These two villages have been given by my hand with my own free will with the gold and water to NARA SINHA DEVA for the daily offerings, &c., while I am ruling the world, sitting on the precious throne, at the time of the moon's eclipse, on the 15th of the moon, in the month of *Vaisákha* or May, in the year *Virodhi*. Whatever rare thing, water, stones or gold may be found within the boundaries of the above two villages, together with the duties on imports and exports have likewise been presented by me to NARASINHA DEVA as a donation with my free will. Let the grant be continued until the sun and moon shall cease to shine.

(Three Sanscrit Stanzas follow, see the Twelfth Inscription.)

---

\* This must be SADASIVA, the brother of ACHITA RAO (ACHYUTA). He is not mentioned in the Pedigree as having sat on the throne.

† Probably 1451.

‡ Raja of Orissa.

§ Raja of Satara.

## TENTH INSCRIPTION.

*A Bond of Donation inscribed at Krishnapuram.*

**F**EALTY to **SAMBHU** on whose head the moon shines, and the *Chámaras* glisten, who is the chief pillar and foundation of the three worlds !

Fortune and victory !

In the reign of *Sáliváhana* 1435, corresponding to the year *Bhává*, in *Phálguna Sudi Tritíya*, *Sukravár*, or Friday the 3d of the moon (in the month of March, 1513.)

The fortunate king of kings, *Parameswara*, the brave and famous, happy and heroic **KRISHNA MAHÁ RÁYA** returning to *Krishnapuram* from *Vidyagerhi* after conquering the king of that city, brought the god or image named **KRISHNA DEVA**, and established it at *Krishnapuram* ; and at the same time presented a great many jewels set with nine sorts of precious stones, and furniture of gold and silver, &c., together with the undermentioned villages, for the divine expences, such as lights, flowers, fruits, incense, &c., and daily and extra offerings, (*Pancha Parvams*)—on the first day of the month, the 11th of the moon, the full moon, the 27th of the moon, and also for the new moon, monthly and yearly festivals, and for the distributions among the *Brahmans*, and for the pomp and splendour of worship.

1 Village called *Atteratti*.

1 Village called *Maddalapuram*, which is added to *Hosuru Magani*.

1 Village named *Devatápuram*, adjoining to *Compili Magani*.

1 Village called *Harya Samudram*, near *Cailáspuram*.

1 Village styled *Togalacullu*.

1 Village by the name of *Badanahati*.

1 Village named *Badrapadam*, which is added to *Tocala Cotuca Chella*.

He also gave the transit duties at *Krishnapuram* as well as in the above villages, together with the lake, as a *Sarvamanyam* to the *Brahmans*. He also determined that the following *Brahmans* should act as the priests, &c., of the said deity, and that they should each enjoy a certain portion of land ; viz.

1 Candy of land to **RÁMÁNUJA ACHÁRYA**, son of **TIMANA ACHÁRYA**, who was of the tribe of **GAUTAMA**, in the rule of *Vikhanus* and of the *Yajusák* or *Yajurveda*.

1 Candy of land to **TIMMANACHÁRYA**, the son of the daughter of **RANGAMMÁ**.

## ELEVENTH INSCRIPTION,

*Written in the old Canarese Language.*

**ADORATION** be unto **SAMBHU** (*Siva*) who is the lord of *Cailás*, the chief pillar to the foundation of the three worlds called "the three *Nagaras*," (heaven, earth, and the lower world or *Pátála*), whose head is encircled with white *Chámaras*, equalling the splendour and magnificence of the full moon.

The deity called **VIGHNESWARA** (*Ganesh*), the son of **SAMBHU** was supposed to have lost his head in battle. His mother **PARVATI** alarmed at the report, induced her husband to search after him. The body was discovered, but every endeavour to find the head proved unsuccessful; **SAMBHU** in his search happening to meet with the head of an elephant placed it as a substitute on the shoulders of his son. **VIGHNESWARA** is on this account represented with the body of a man bearing the head and probosis of an elephant. He was supposed to have been a proficient in all languages and sciences. He was distinguished by a symbol of the moon on his head. His body was painted over with a composition of oil and red lead, which made him appear like the red clouds of the evening.

He drank up the water of the tanks with his trunk and sprinkled it like a shower on the earth. The dignity and splendour of his body equalled the brilliancy and radiance of the red sky occasioned by the dust of the earth when stirred up by the hoofs of the cattle returning from pasturage in the evening. He protected the good, and his disposition was uniformly happy. He watched over **LAXMAN MANTRI**, the minister of State, who possessed every good and perfect gift, and who was accomplished in all the arts and sciences.

The dust of the feet of **LAXMIVARAGURU**, the priest of **LAXMAN MANTRI**, has the property of removing the sins of the multitude as the water of the Ganges, which springs from the toe of the Almighty **VISHNU** in his habitation of *Vaicantha*, and purifies the sins of men.

The minister, **LAXMAN MANTRI**, was the lord of the earth, and the ruler of many kings. He resembled **VISHNU**, whose shape is revealed in the *Védas*, and who sprang from the lower world (*Pátála*) in the form of the boar *Adivaráham*, whose tusk having mount *Méru* for a socket, sustained the whole world.

May the bud of the lotus, which is in the hand of **LAXMI**, the wife of **VISHNU**, containing boundless wealth, be given to **LAXMAN MANTRI**. The shape of that

bud is like the shell, which was used to pour milk into the mouth of the infant BRAHMÁ, who was born from the navel of VISHNU when reclining on *Adisésha*, the thousand mouthed serpent, floating on the milky sea. BRAHMÁ, the son of VISHNU, had a son named ATRI, who is the father of CHANDRA, or the moon, who begat BUDHA. PURURAVA, the son of BUDHA, had a son called AYU, who begat NAHUSHA. NAHUSHA had a son named YAYATI, who begat YADU, &c.

The descendants of *Chandra*, or the moon, were all kings of great fame and renown. In the line of YADU was born SRI SANGAMATBHUMIPATI, who had a son called BUKKA RÁYA, who reigned in the circular or oval world. He was valiant in battle, and remarkable for his military acquirements. His younger brother HARI HARA DANDINARENDRA, however, excelled him in every accomplishment, and was extolled by the kings of the earth for his generous and forgiving disposition, which extended not only to them but to the seven parts of the earth called *Saptadvípa*. HARIHARA BHUPÁLA, the son of BUKKA RÁYA, was valiant as VISHNU, who modelled the earth. His charity and benevolence exceeded that of NALA, NAHUSHA, NRIGA, BHAGHIRATHA, &c., and in consequence his reputation equalled in brilliancy the splendour of the full moon.

He had a son named DEVARÁJA NARENDRA, who planted the ensigns of victory on every side, and who was entitled to use the white umbrella over his head. He banished the poverty of the people by his munificence, and by the water of his bounty extinguished the heat of their miseries. He was king of kings, and had all the monarchs of the earth under his subjection. He was the source of all riches as he was the chief amongst the kings. He possessed a sword like the *Vajrayuda* in the hand of INDRA, to conquer the mountains of his enemies. He was also distinguished for his charitable virtues, which shone as bright as a meteor in the sky. This king afforded protection to all his allies by giving them assistance in the hour of need against their enemies.

DEVA RÁYA BHUPÁLA, the fortunate, had two ministers named DHARMADARSA and SAVENA, who erected a great number of temples, &c. for charitable purposes, and endowed them with villages. The fame of their king was by these means spread abroad throughout the earth.

These two ministers had a sister called SINGHAMBHU, who was celebrated for her virtue as well as beauty. She was an ornament to her sex, and her husband named RÁMARÁSU, of the tribe of *Muniswara*, or penitents, was loved by the world for his excellent qualities.



RÁMARÁSU had five sons named LAXMAN MANTRI, CHINA MANTRI, BAKANA, ABUNA and MADANA, who were esteemed and celebrated in the world, as much as the five wishing trees, called *Santána*, *Calpavrixa*, *Mandára*, *Harichandana* and *Parijata*, which grew in the garden of INDRA, the Lord of Paradise.

Of these five brothers LAXMAN MANTRI was most distinguished for his strength and symmetry, which equalled that of BHÍMA. He was valiant and courageous, and his fame rose like that of ARJUNA, the third brother of DHARMARÁJA or the son of PÁNDU, and like that of DASARATHA, RÁMA, whose glory was as the moon of the nectarine sea called the womb of *Sangamámbu*. He was loved by the people and his name encreased daily. LAXMAN MANTRI afforded protection to all his friends as well as to strangers, and he constructed a great many lakes and wells. His hand was open and generous as the wishing tree *Calpavricsham*, and so numerous were his charities and liberal donations that CARNA, a king famous for these qualities, was entirely forgotten.

LAXMAN MANTRI was minister to the king DEVA RÁYA BHUPÁLA, and was loved by the nobles for his extensive acquirements in literature and the sciences.

In public or in private he was equally esteemed for his virtues, wealth, greatness, generosity, and personal bravery, &c.

The women who saw LAXMAN MANTRI, while sitting in the light of the full moon in summer, were dazzled by his beauty, and intoxicated with love.

A great many authors and learned men composed verses, &c., in his praise.

In the dominions of DEVA RÁYA, LAXMAN MANTRI was the chief of men and excelled the minister of PRÁTÁPA RUDRA, called VANAKA, and YOGENDRA in firmness, wisdom, wit and resources.

One night LAXMAN MANTRI being asleep, dreamt that a deity called VINAKA appeared before him, having his feet adorned with *Andal* and *Cadam*, and his waist with a gold band. He had a crown on his head set with nine sorts of precious stones, and the symbol of full moon was placed above the crown. He had four hands, each of which held an instrument. The deity addressed LAXMAN MANTRI saying, "There is a place called *Virupaksha*, where lasciviousness, revenge, lust, &c. are unknown, which would be a pleasant spot for the three principal deities called HARI, (or VISHNU) HARA (or SIVA) and HIRANYAGARBHA, or the four-headed god BRAHMA. It is situated in the south side of the mountain called *Meru*, in the middle of the island called *Jambudwipa*, and encompassed by the salt sea called *Savana Samudram*. In the same place there is a river called *Penákeni*, whose waters are like *Anritam* (nectar), and abound with fish, turtles, alligators, &c. On the banks of the river there are many groves composed of mangoe,

citron, plantain, limes and other sorts of fruit trees, intermixed with all sorts of flowers and plants named *Malli, Malla, Janji, &c.*, the abode of nightingales and other beautiful birds. This is the holiest spot in the world, where the axe of penance and devotion is laid to the root of the vine of sin. In it there is a place called *Pumpátir*, to the east of which there is a mountain called *Malayávanta*, to the south side of which again there is a cave where I recommend you to build my temple."

LAXMAN MANTRI in accordance with the injunction of the deity erected a temple in which he placed the auspicious VIRUPÁKSHA DEVA with PÁRVATI, his wife, and their son GANESA or PINÁKA on the bank of the river *Pampa*, to the south side of the mountain *Malayávanta*, whose glory shall last until the sun and moon pass away.

---



---

TWELFTH INSCRIPTION.

*A Bond of Donation written on the stone near Ranga Mantapam before the Temple of the Holy VIRUPAKSHA.*

---

**MAY** fortune and victory endure!

In the year of *Sáliváhana* 1430, corresponding to the year *Sukla*, in *Mágha Bahula Chatardasi*, or on the 29th of the moon (in the month of March, 1508.)

The fortunate, the great king of kings, *Parameswara*, brave and valiant, happy and heroic, KRISHNA MAHÁ RÁYA, while sitting on the throne, presented a village, *Singhalli*, for the supply of the daily offerings, together with a newly built edifice called *Ranga Mantapam*, and a tower opposite to it, and also a large old tower lately repaired, which is at the first gate. He presented to VIRUPÁKSHA a *Camalam* and a *Nágánbharanam* set with nine sorts of precious stones: the shape of the former was that of the petals of the *Támari* (lotus) flowers, and of the latter that of a serpent. He also presented a large gold plate for the purpose of holding the daily offerings of food, and two small plates of the same metal for holding small lights, together with seventy-four other plates made with silver. He, who shall not continue the charity, will commit as great a sin as if he had slain a cow or *Brahman*.

STANZAS.

I.—The king sitting on the precious throne, dwelling in the city of *Vijayanagar*, his name is extended over the earth. In administering justice he excels the sovereigns NRIGU, NALA, and NAHUSHA.

II.—The virtue of giving is greater than that of continuing a charity. Giving obtains heaven, and continuing paradise.

III.—If a person continue all the gifts of others it is twice better than one of his own, should he resume those of others his own will be in vain.

IV.—If a person resume his own gifts or those of others he will be born as a mite or worm, and live sixty thousand years in dung.

V.—RÁMACHANDRA wishes all kings now and hereafter to continue to give in charity, because it is a duty appointed to man as the shore is to the sea.

---

FOURTEENTH INSCRIPTION.

*A Bond of Donation written on a stone called Vay in the Temple of Madávaswámi.*

---

OBEISANCE to GANÁDÍ PATI (or GANAPATI\*), the general of the army of the deities.

Fortune and victory!

In the year of *Sáliváhana* 1467, corresponding to the year *Viswávasú*, in *Krishna Sudi Tritiya, Guruváram*, or on Thursday the 3d of the moon (in the month of April 1545.)

The fortunate, the great king of kings, *Parameswara*, happy, famous, and heroic, SADÁSIVA MAHÁ RÁYA was ruling the world, sitting on the precious stone, holding an umbrella over his head when TIMMA RANGA, son of VRITTABHA RANGA presented a building called *Ranga Mantapam* or “public resting place,” with twenty-five partitions to the God MÁDHAVA DEVA, (whose temple is in the city of *Vijayanagar*, at the great bázár, west of the *Metananta*). The proceeds thereof are to be appropriated to the expence of the daily festivals, drums, flutes, &c., which may be necessary for the pomp and splendour of the temple.

This gift is given by him in the name of his father VALLABHA RANGA and mother VENGALOMÁ, that they may obtain salvation. Let the gift be inviolable until the sun and moon shall cease to shine in the world.

---

\* This is apparently a mistake for the younger brother of GANPATI named KARTIK is called “DEVA SHENAPATI,” (general of the army of the deities).

---

*Transcript of the First Inscription from the Tailanga into the Devanāgarī character.*

आनेगुंदिक्किपोय्येदोवकोपूर्वमंदु उखे जैनगुडि यदबध्वजस्तंभमीद उखे शासनं

यत्यादपंकजर्जोरजोहरति मानसं । सजिनस्वैयसे भूयाद्भूयसे करुणाणयः । १ । श्रीमत्परमगम्भोर  
स्यादादामोघलांरुनं । जीयात्रैलोक्यनाथस्य शासनं जिनशासनं । २ । श्रीमूलसंघेऽजनि नंदिसंघस्तस्मिन्  
वशातारगजेतिरन्ध्रः । तत्रापि सारस्वतिनाम्नि कश्चित् स्वभाश्रयोभूदिह पद्मगंदी । ३ । आचार्यः कुण्डपा  
दाख्योवक्रदेवोमहामतिः । राजाचार्यैर्गंधर्षिण्ड इतितन्नामपंचधा । ४ । केचित्तदन्वये चारमुनयः स्तनयो  
गिरां । जलदादिवरत्नानि बभूवुर्दिव्यतेजसः । ५ । तत्रासीचाबचारित्र रत्नरत्नाकरोमुहः । धर्मभूषणयो  
गीन्नेभट्टारकपदांचितः । ६ । भातिभट्टारकोधर्मभूषणो गुह्यभूषणः । यद्यश्चःकुसुमामोदेगगनंभमरा  
यते । ७ । शिष्यस्तस्य मुनेरासीदनगंश्रतपोनिधेः । श्रीमानमरकीत्यार्थदेशिकाये सरश्रमी । ८ । निजपद्य  
घटेकपाटं घटयित्वाजिननिरोधिताद्रावे । अतिचलितबोधदीपंतममरकीर्त्तिं भजे तमोहरणं । ९ । श्री ॥  
सावित्रान्वयपूरुषाः परिब्रताविद्याविहीनांतरा योग्या वा भुवि संभवंतु बहवः किंतैरनंतैरिह । १० ।  
धीरस्फूर्जितदुर्जयातनुमबहंसीगुणैरुर्जितैराचार्यामरकीर्त्तिं तस्मभभवश्चीसिंदगंदी कृती । ११ । श्रीधम्म  
भूषोऽजनि तस्य पदे श्रीसिंहनंदार्यगुरोः सधर्मः । भट्टारक श्रीजिनधर्महृन्धस्तंभायमानः कुमुदेदुकीर्त्तिः  
। १२ । पदे तस्य मुनेरासीद्दहमानमुनीश्वरः । श्रीसिंहनंदियोगीन्द्रचरणांभोज घटपदः । १३ । दहमान  
गुरोरासीद्दहमानभूषणकीर्त्तिकः । भट्टारकमुनिः श्रीमान्प्रत्ययविवर्जितः । १४ । भट्टारकमुनेः पादाव  
पूर्वकमले क्षुमः । वदये मुकुलीभावं यांति राजकराः परं । १५ । पवरेमवपरंपरायामदीर्घेदेनवत्तंमा  
नायां । आसीदधीममहमावंशे यादवभूयतां । १६ । अखंडितगुणोदारः श्रीमान्बुद्धमहीपतिः । उद  
भूद्भूतस्तस्माद्राजाहरिहरेश्वरः । कलाकलापनिकयो विधुः क्षीरोदधेरिव । यस्मिन् भर्त्तरिभूपाजे  
विक्रमाक्रांतविष्टये । पिरात्राजन्वतीहंतभवसोषा वसुंधरा । तस्मिन्शासति राजेने चतुरांघ्रिमेखलां ।  
धरामधरिताशेषपुरातनमहीपती । आसीत्तस्य महीजानेश्चक्षिप्रयसमन्वितः । कुलकमागतोमंची चैत्र  
दंडादिनायकः ॥

द्वितीयमंतः करुणं रहस्य स बाळलेयस्ममरांगणेषु । श्रीमान्महान्चैत्रदंडनाथो आगतं कार्थ्ये हरि  
भूमिभर्तुः ।

तस्य श्रीचैत्रदंडादिनायकस्याजितश्रियः । आसीदिरुगदंडेशोवंदनोकोकनंदनः ।

न मूर्त्ता नामूर्त्ता निखिलभुवनाभोगिकतया शरद्राजद्राकाविटनिटिकनेत्रं धृतितया । प्रभूताकीर्त्तिं  
स्वाचिरमिदगदंडेशकथय त्वदेकांतात्कांतात्पुरमिह न किंचिन्मतमिति । तदंशोपि गुह्यवानपि मार्गं  
ज्ञानामाधारतामुपगतो पितृ यस्य चापः ॥ नन्परं तस्यज्जिनायखलुशिक्षयतीवनीर्त्तिं ।

हरिहरधरबीशः प्राण्यसाम्नाज्यलक्ष्मीः कुवलयह्रिमधामा श्रौथ्यं गांभीर्थ्यसीमा । इदगपदरखेता  
सिंहनंदार्यवर्थ्यं प्रपदनस्मिन्मंगः स प्रतापैकभूमिः ॥

स्वस्तिशाकवर्षे १३०७ प्रवर्त्तमाने क्रोधनवत्सरे षाष्टगुणमासे कृष्णपक्षे द्वितीयायां तिथौ शुक्रवारं ।  
अस्ति विस्तीर्णकगांठधरामंडलमध्यगः । विषयः कुन्तजोनासा भूकांताकुन्तजोपमः । विचित्ररत्नरुचिरं  
तत्रास्तिचिदवाभिधं । नगरंसारसंदोहवर्जिताकांडचंद्रिका । मखिसज्जमवीथीषु मुक्तासैकतसेतुभिः ।  
दासां भोभिनिबंधाना यत्र क्रीडति बालिका । तस्मिन्निदगदंडेशो हरिचाबसिजामयं । श्रीकुंडुजिन  
नाथस्य चैत्यालयमचीकरत् ॥

Second Inscription, Original in Tailanga Character.

श्रीगणेशायनमः ।

श्रीछायापुरजोवुंडेदेवालयमुजोवुंडेशासनाभिप्रायम् ।

नमस्तुंगशिरश्चुंबिचन्द्रचामरचारवे । चैलोक्यनगरारंभमूलकंभाय शंभवे । १ । नवगीरदनीलाय जव  
नीतनतार्तये । अवगीकमनीयाय नवगीतमुषे नमः । २ । कांचीश्रीशैलश्रीशाचलकनकसभा वेंकटात्रिप्रमु  
ख्येष्वावत्यांवात्यंस्वैष्वतनुतविधिवद्रेयसे भूयसे यः । ३ । देवस्थानेषु तीर्थेष्वपि कनकतुलापूरुषादीनि  
नानादानान्येवोपदानैः सममखमखिलैरागमोक्तानि तानि । ४ । दोषकृतप्रतिपार्थिवदखः श्रेयभुजःक्षिति  
रक्षयशौखः । भाषिगेतेप्युवरायरगखः तोषकृदर्थिमयोरकचखः । ५ । राजाधिराजइत्युक्तेयोरारा  
परमेश्वरः । मूरारायरगखश्च पररायभयंकरः । ६ । हिंदुरायसुरचाकदुष्टशार्दूलमहंनः । गजौघगंड  
भेवंड इत्यादिविरदान्वितः । ७ । आलोकय महाराज जयजीवेतिवादिभिः । अंगवंगकलिंगाद्यैराज  
भिषोयते च यः । ८ । कुत्यौदार्यकुधीभिश्च विजयनगरे रत्नसिंहासनस्थः क्षायाणः कृष्णरायः क्षिति  
पतिरधरीकृत्य नित्यं ऋगादीन् । आपूर्वाग्नेरथास्तक्षितिधरकटकादाचहेमाचकातादासेतोरथिसार्थ  
भियमिह बज्जीकृत्य कीर्त्यासमिन्दे । ९ । सोयं श्रीपदकृष्णरायन्प्रतिजिज्ञोदयामिं ततः कृष्णं देवमुपा  
यितस्थनगरीं नीत्वा मञ्जीमण्डपे । शाशीयाब्दरसाभिवेदविधवे जाते तपस्ये सिते तार्तीये दिवसे वृषेऽपि  
विधिवत्कृष्णप्रतिष्ठां यथात् ॥

खलि श्रीविजयाज्यदयाशालीवाहनशकाब्दाः १४३६ । नेयपोधितवांतनुवावनामसंवत्सर फासगुख  
शुद्ध ३ शुक्रवारमंदुश्रीमन्महाराजाधिराज परमेश्वर श्रीवीर कृष्णदेवमहाराय सुवाबडदयगिरिनं  
चिविजयचेखुनिवचित्रीवाककृष्णस्वामिप्रतिष्ठाचेभि आप्रतिष्ठाकाकमंदु आकृष्णदेवुक्किनवरत्न  
खचित नानाविधाभरत्तुनुसुवर्णरजितोद्युपकरत्तुनुसमपंखंचेभिदेवुनिश्रीकार्या न कुगानुदीपारा  
घन फलपुष्पादिनित्यनैवेद्यमुलकुयी नैमित्तिकपंचपर्यरथमहोत्सव ब्राह्मणविनियोग अंगरंगवैभोग  
मोदलैनविनियोगालकुगानुतत्कालमंदुसर्वमान्यंगानुजोडिविराडसार्थनाडतकारिकंसंकांकरबीकलसा  
न्याकवरिमंसुसकलसुवंधंदायमु सकलदान्यादायमुमोदलैन विसर्वमान्यंगानु समर्पिषियामालुडलिगे  
मागखिलोपलवुंडेअत्तिवेद्विदान्किचेक्षेमेद्रवर्त्तनलोगाखले विक्रलोनायकित्तिअनेवर्त्तनचिंतमा कुलपद्म  
वर्त्तनतिम्भनायकित्तिवर्त्तन येति आवलसुंकांकट्टुंजोउंडेहरिगोलु आडेवांडुयुयिनिवर्त्त नोकूडा अत्ति  
वदृष्यनेग्रामं वखटि कंपिलीमागाखिलोपलिचेर्निर्देवलापुरमनेग्रामं १ होसूरबमागानिचेरि न मुद्रत्का  
पुरग्रामं १ यीसीमकुचेरिनवादन हट्टिग्रामं १ यीसीमकुचेरिनतोगलुकंजु १ कलसापुरंमागाखि  
चेरिनहरियसमुद्रग्रामं १ तेंकलकोट सीमकुचेरिनबन्न पादमनेग्रामं १ इंश्वरसंवत्सरमार्गशिरवंडख  
५ सुतिवपंडिसमर्पिषिनाम् ॥

K

Third Inscription, transcribed in the Devanagari Character.

श्रीमत्समरगम्भीरखेच्छदामोघलाङ्गनं । जियात्रैलोक्यनाथस्य शासनं जिनशासनं । चू । श्रीमद्यादवा  
 न्वयाखं वपुषं चन्द्रस्य श्रीवृक्षमहीपतेः परिश्रुतमूर्तेः स्वामीर्त्तं हरिहरमहाराजस्य पर्यायावतारादीराद्देव  
 राजनरेश्वराद्देवराजादिव विजयश्रीवीरविजयनृपतिस्वजातस्तस्माद्देहवाद्देरिव महामाखिक्यकांडोन्न  
 तिप्रतापस्थिरीकृतसाम्राज्यसिंहासनः राजाधिराजपरमेश्वरादिविषदविख्यातोमुक्तनिधिरभिनवदेव  
 राजमहाराजो निजाच्चाप्रतिपाणितकर्नाटदेशमध्यवर्तिनः स्वावासभूतविजयनगरस्य क्रमुकपर्षपस्थवी  
 थ्यामाचन्द्रतारमात्मकीर्तिधर्मप्रवृत्तये सकलज्ञानसाम्राज्यादिविराजमानस्य सदाद्विद्याप्रकटनपटी  
 यसः पार्श्वनाथस्य श्रीपतेः शिलामयं चैत्यागारमधीकरत् ॥ स्तो ॥ देशः कर्नाटनामाभूदावासस्त्वसंपदां ।  
 विडंबयति यस्वर्गं पुरोडाशासनान्वयं ॥ विजयनगरीति तस्मिन्नगरीतिरव्यहृष्यास्ते । नगरीषु गरीय  
 सीयं नगरीस्त्रैरेव गुहभिरैश्वर्यैः ॥ कनकौज्वलसाररश्मिजाणैः परिखाम्बुप्रतिविंवितैरलं या । वसुधैव  
 विभाति बाहवार्धिवृत्तिरजाकरमेखलापरीता ॥ श्रीमानुद्दामधामा यदुकुणतिजकस्फारसौंदर्यसीमा धी  
 मान्नामाभिरामाकृतिरवनितले भातिभाग्यात्तभूमा । विक्रांत्याक्रान्तदिक्कोविमतधरखिद्यत्यकजश्रेष्ठि  
 दिक्कः सौख्यां जागर्ति वृक्षः क्षितिपतिरिभूभृन्निरस्यतृषत्कः ॥ तस्यात्तात्मावतारः स्फुरति हरिहरस्या  
 पतिज्ञातसारो दारिद्र्यस्फारवाराकरतरङ्गविधौ विस्फुरत्कण्ठधारः । भूदानस्वर्गदानानुक्तपरमुभृत्य  
 श्मिनीबंधुसुगुः स्फाराजूपारतीरावणिनिहितजयस्वामिविन्यस्तकीर्तिः ॥ तेनाज्यरिराजतन्नतशिरस्तोम  
 स्फुरच्छेखरप्रत्युत्तोरपदीपिकापरिकल्पितादाङ्गीराजनः । विदत्तैरवमंडलीहिमकरोविख्यातवीथ्याकरः  
 शेषाङ्गीररमाख्यंबुतवरः श्रीदेवराजेश्वरः ॥ तज्जन्वोऽस्मिन्वदान्योजगति विजयते पुष्पचारित्रमान्यो  
 दानध्वस्तार्तिदेव्योविजयनरपतिः खण्डितारातिसैन्यः । प्रत्युद्योज्ययात्रासमसमयसमुद्भूतक्रेतुप्रसूत  
 ह्यावाव्योपहृत्याप्रतिहतविमताघप्रतापप्रदीपः ॥ तस्मादस्माञ्जितात्माजनि जगति यथाजंभजेतुर्जयं  
 तो राजा श्रीदेवराजोविजयनृपतिवाराशिराकाशशांकः । कौपाटोपप्रवृत्तप्रवलरश्मिजहिप्रतीपक्ष  
 मापप्राज्ञशेखीनभस्त्रिवहकवलसंयग्रखण्डोरगेंद्रः ॥ वीरश्रीदेवराजोविजयनरपतेस्वारसंजातमूर्ति  
 र्मर्त्ताभूमेर्विभाति प्रखतरिपुततेरार्तिजातस्य हर्त्ता । क्रूरजोघोषयुद्धोद्धरकरटिघटाकण्ठभ्रूपंप्रसर्पबा  
 वत्रातोपघातप्रतिहतविमतादम्बदर्पाभसंघः ॥ यद्वाटीघोरघोटीस्फुरदलितधरारेणुभिवंप्रवेष्टैर्धूमको  
 मायमानैः प्रतिनृपतिगबस्त्रीदृशस्त्राशुधाराः । प्रोम्बन्दपंप्रभूतप्रतिभटसुभटस्याटनाटोपजायत्रोवो  
 त्कधौधकारद्युमखिरुदयते देवराजेश्वरोयं ॥ विश्वस्मिन्विजयक्षितीशजनुषः श्रीदेवराजेशितुर्लक्ष्मीः कीर्ति  
 सितांबुजं कलयते श्रेय्याख्यसूर्योदयात् ॥ आशा यत्रपलाश्रतामुपगताखण्डाचक्षः कश्चिका भंगादिक्षु  
 मर्तमजाजलधयोमारंदधिदृत्तराः ॥ विख्याते विजयात्मजे वितरति श्रीदेवराजेश्वरे कर्षस्याजनिवर्षणा  
 विगजिताबाष्पादधीष्वादयः । दोषाग्रामपि मोघतापरिग्रता चिंता न चिंतामयेस्वल्पः कल्पमहीबहः  
 प्रघयते स्वर्षेचिकी नीचता ॥ सोयं कीर्त्तिसरस्वतीवसुमतीवाखीवधूभिः समं भयो दीव्यति देवराजनृप  
 तिभूदेवदिव्यद्रुमः । यश्रौरिर्बलियांचनाविरहितसन्त्रःकलकौञ्जितप्रशूकस्वत्यमगोत्रभिद्दिनकरश्वास  
 त्यदोक्ताङ्गनः ॥ मदनमनोहरमूर्तिर्महिलाजनमानसारहरणः । राजाधिराजराजपरमेश्वरादिनिजविह  
 दः । शतौ वृक्षमहीपालो दाने हरिहरेश्वरः । श्रेय्यै श्रीदेवराजेशो ज्ञाने विजयभूपतिः । सोयं श्रीदेव  
 राजेशो विद्याविनयविश्रुतः । प्रामुक्तपुरवीथ्यंतपर्षपूगणकापणे ॥ शकाब्दे प्रमिते याते वसुसिंधुगुणै  
 दुभिः । पराभवाब्देकार्त्तिक्यां धर्मकीर्त्तिप्रवृत्तये ॥ स्यादातमत्समर्थगखर्षितदुर्बादिसर्ववाग्वितते  
 अष्टादशदोष महामदगजनिपुरम्बमहितनृगराजः । मिथ्याम्बोदह भानोरिन्द्रादिसुरेन्द्रवंद्यवद्यस्य मुक्ति  
 वधूप्रियप्रिय भर्त्तुःश्रीपार्श्वजनेश्वरस्य कदम्बाब्दे । भयपरितोषहेतुं शिलामयं सेतुमखिणधर्मस्य  
 चैत्यागारमधीकरदाधरखिद्युमखिहिमकरं स्वेयं ॥

Fourth Inscription.

श्रीविरूपाक्षेश्वरगुडिरंगमठपंथेदुर्गगानिधिपिउंदेशासनं ।

श्रीकृष्णदेवरायण ॥

शुभमस्तु ॥ नमस्तुंगशिरस्त्रिचन्द्रचामरचारवे ॥ त्रैलोक्यनगरारंभमूलस्तंभाय शम्भवे ॥ कल्याणायान्तु  
तज्जामप्रत्यूहतिमिरापहं । यद्गुजोप्यगजोद्भूतं हरिणापि च पूज्यते ॥ अस्ति क्षीरमयाद्देवैर्मथ्यामानान्महा  
शुभः । नवनीतमिवोद्भूतमपीततमोपहः ॥ तस्यासीत्तनयस्तपोभिरतुलैरन्वयं नामाबुधः पुण्यैरस्य पुरु  
रवोभुजबलैरायुर्जिवांनिघ्नतः । तस्यायुर्जघोऽस्य तस्य पुरुषोयुजे ययातिः क्षितौ ख्यातस्तस्य तु तुवंस  
र्वसुनिभः श्रीदेवयानीपतेः ॥ तदंशे देवकीजानिर्दिदीपे तिम्रभूपतिः । यशस्वी नृपतीन्नेषु यदोःकृष्णइवा  
न्वये ॥ ततोऽभूदुक्ताभूजानिरीश्वरक्षितिपालकः । अन्नासमगुण्यंशं मौलिरत्नं महीभुजां ॥ पद्माक्षोबल  
वान्निजैस्त्रिभुवनक्रांतिक्षमैर्विक्रमैः शंखं चक्रमपि अयन्निककरे श्रीदेवकीन्दनः । भूलाप्यद्भुतमीश्वरोव  
मिति योभूयस्तरां पप्रथे भूतिं चाखिलपूज्यतामतिभयं भूभ्यस्तामाश्रितः ॥ भूवासैकपरोपरोरविरिव  
प्राप्नोदयोहनिशं योऽयं देहरिपूनहन् कविवुधोपेतोनपेतोरखात् । आपूर्वापरवारिराश्रितिरामासेतु  
हेमाचक्षं विख्यातावहसंश्रयोवितरथैर्यद्योतत द्योतरुन् ॥ सरसादुदभूत्सामरसावनिपालकः । देव  
कीन्दनात्कामो देवकीन्दनादिव ॥ कावेरीमाशु बध्ना बज्जलजलरयां तां विलंध्येव शत्रून् जीवयाहं गृही  
त्वा समितिभुजवलात्तं च राज्यं तदीयं । हत्वा श्रीरंगपूर्वं तदपि निजवशे पट्टं योवभासे कीर्त्तिसंभं  
निखाय त्रिभुवनभवनस्तुयमानापदानः ॥ चेरं चोलं च पाण्यं तमपि चमधराबल्लभं मानभूषं वीर्यादयं  
तुह्यं गजपतिष्टपतिं चापि जित्वा तदन्यान् । आगंगातीरलंकाप्रथमधरमभूत्सटांतां गितांतं ख्यातः  
क्षौभीपतीनां खजमिव शिरसां शासनं योय्यतानीत् ॥ विविधसुकृतोद्गमे रामेश्वरप्रमुखे मुकुन्दितह  
दयस्थाने अघत्त यदा विधिः । बुधपरिवृतो नानादानानि यो भुवि घोडशत्रिभुवनजनेद्रीतं रक्षीतं यशः ।  
तिप्याजीनागलादेथोः कौशल्याश्रीसुमित्रयोः । देखोरिव नृसिंहेद्राजस्मात्पंक्तिरथादिव । वीरौ च  
नियतौ रामकृष्णविव गन्धौ । जातौ वीरनृसिंहेन्द्रकृष्णरायमहीपती ॥

वीरश्रीनारसिंहस्य विजयनगरे रत्नसिंहासनस्यः कीर्त्या नित्यं निरस्यन् नृगनजनजडवानथवस्थान् वदा  
न्यान् । आसेतोरासुमेरोरवनिस्तरुतः खैरमाचोदयात्रेराहत्यांभूवलांतादखिलहृदयमादृत्य राज्यं श  
शास ॥ नानादानान्यकार्षीत्कनकसदसि यः श्रीविरूपाक्षदेवस्थाने श्रीकालहस्तीश्रितुरपि नगरे वेङ्कटाश्रौ  
च कांथां । श्रीशैले शोणशैले महति हरिहरेऽहोवले संगमे च श्रीरंगे कुंभकोशे हरतमसि महानंदि  
तीर्थे नृवृत्तौ । गोकर्णे रामसेतौ जगति तदितरेष्वप्यशेषेषु मुख्यस्थानेष्वारध्नानाविधबज्जलमहादान  
वारिप्रवाहः । अस्त्योदं चतुरंगप्रकरखुररजःशुभ्यदंभोधिमध्यस्थाभ्यत्पक्षिदोद्यत्खरकुलिशं धरोत्कं  
डिता कुठिताभूत् । ब्रह्माख्यं विश्वचक्रं घटमुदितमहाभूतकाणांतदेनुं सप्ताम्भोर्धींश्च कल्पक्षितिबहव  
तिकाकांचनं कामधेनुं । खड्गेष्वपो हिरण्याश्वरथमपि तुजापूरुषं गोसहस्रं हेमाश्वं हेमगर्भं कनककारि  
रथं पंचलांगल्यतानीत् । प्राच्यं प्रशास्यं निर्विघ्नं राज्यं द्यामिव शासितुं । तस्मिन् गुणेन विख्याते क्षिति  
रिन्ने दिवं गते ॥ ततोऽप्यवार्थवीर्यं श्रीकृष्णरायमहीपतिः । विभर्ति मखिकेयूरनिर्विशेषं महामुजे ॥  
कीर्त्या यस्य समंततः प्रहृतया विश्वं रचैकं ब्रजेदित्याशंख्य पुरा पुरारिरभवद्भालेक्षः प्रायशः । पद्मा  
क्षोऽपि चतुर्भुजो जनि चतुर्वक्त्रोऽभवत्पद्मभूः कालीखड्गमदाद्रमा च कमलं वीणां च वाशी करे ॥ शत्रूणां  
वासमेते दधतहति रघा किंनु सप्तांवुराशीत् नानासेनातुरंगत्रुटितवसुमतीधूलिकापाणिकाभिः । संश्रो  
यत्स्फीतमेतत् प्रतिनिधिजलधिःश्रेणिकायो विधत्ते । ब्रह्माख्यखड्गमेव प्रमुखनिजमहादानतोयैरमेयैर्मह  
त्तामर्थिसार्थश्रियमिह सुचिरं भुंजतामित्युदीयन् । प्रायः प्रत्यूहहेतोः ॥

कांभीमीशैलकोशाचलकनकसभावेकटात्रिप्रमुख्यावल्यावत्यसर्व्वेध्वतनुतविधिवद्रूपसे श्रेयसे यः ।  
 देवस्थानेषु तीर्थेष्वपि कनकतुलापूरघादीनि नानादानान्येवोपदानैरपि सममखिलैरागमोक्तानि तानि ।  
 दोषहृतं प्रति पाश्चिं वदंढः श्रेयभुजक्षितिरक्षत्रश्रीः । भासिगेतपुवराय रगंडसोवहृदधिंमयोरब  
 चब्दः । राजाधिराजइत्युक्तोयोरराजपरमेश्वरः । मूरराय रगळ्खपररायभयंकरः । हिंदुरायसुरचाबा  
 हुष्टशार्दूल महंनः । गजौघगंडभेबंढ इत्यादिविबदांनितः । आलोकयमहाराजजयजीवितिवादिभिः ।  
 अंगवंगकलिंगाद्यैराजभिः सेव्यते च यः । सुखौदार्यं सुधीभिस्व विजयनगरे रत्नसिंहासनस्यः क्षापाणः  
 कृष्णरायः क्षितिपतिरधरीकृत्य नित्यं नृगादीन् । आपूर्वांशैरथास्तक्षितिधरकटकादाचहेमाचक्षान्ता  
 दासेतोरधिसाधन्वियनिह वज्रकीकृत्य कीर्त्या समिधे ॥ ५ ॥ इहकिञ्चजगतीनिखिलकविकुलाभिनन्द्य  
 मानौदार्यधैर्यश्रौंशैर्दिजनितयशःपूरकपूरपूरितत्रसाखकरश्चैनश्चवहृसितनृगनज्जनाभागधुन्नुमारमा  
 न्याहभरतभगीरथदशरथरामादिचरितेन सङ्गद्रूपसुरचाजेन परिभूतसुरचाजेन गजपतिगजकूटपाक  
 सेन विदितनामाकसेन वदनविसितांभोजेन भोजेनावरेख काव्यनाटकांकारमर्मज्ञेन धर्मज्ञेन  
 प्रतिवधंप्रतिवर्द्धितकनकवसंतमहोत्सवेन सवेन कृतार्थितविप्रसार्थेन सार्थेन निखिलश्रुतिमूर्द्धन्येन  
 धन्येन नामांविज्ञानरसन्दपनंदनेन निखिलहृदयानंदनेन समरमुखविजयेन विजयेन दिग्धां विजय-  
 नगरे सिंहासनमाह्वय्य शासत सकलांबुर्वज्रविजितसांपरायब्रह्मदेवमहारायेब भुवनभरखसावधा  
 नाय श्रीविरूपाक्षाभिधानाय वितोबंविनतजनहेमकूटाय हेमकूटायतनशासिने श्रुतिने मधुरयज्ञपूपा  
 दिप्राथाय नैवेद्याय शिंमनायकनहृक्षितिविरखातनामचतुःसीमाभिरामोयामदत्तोवित्तोपकारिबे रवि  
 तनयानकारिबे रंगमंठपोपिविरचितस्त्येव देवस्य तेनैव प्रकटितनरजनुषा प्रसूनजनुषा तदिदमवनि  
 मवनिपकविगुतधरायस्य कृष्णरायस्य शासनमिति विलशासन तदुक्तदानस्य सावदानस्यर्षी ॥  
 कक्षीतुंगकुचानुसंमसुखतोत्सोद्भोमीलगां साभीतामरसेन मीलनजुषानाद्ये शिरोनिष्ठुते । हेमावे  
 हतयाविश्वंक्रमनवा प्रत्योपमूढोदृढं पायानाडनृपालतिश्वधरबीपालं मुदा माधवः ॥

(The rest of the Inscriptions, being in the Tailanga and Canarese language and characters, for which type are not readily procurable in Calcutta, are omitted; the translations being thought sufficient to explain their purport.)



II.

---

ANALYSIS OF THE DULVA,  
A PORTION OF THE  
TIBETAN WORK ENTITLED THE KAH-GYUR.

---

BY MR. ALEXANDER CSOMA KÖRÖSI,  
SICULO-HUNGARIAN OF TRANSYLVANIA.

---

THE great compilation of the Tibetan Sacred Books, in one hundred volumes, is styled *Ká-gyur* or vulgarly *Kán-gyur* (བཀའ་རྒྱུད་, *bkah-hgyur*) i. e. “translation of commandment;” on account of their being translated from the Sanscrit, or from the ancient *Indian language*, (རྟེན་ལཱ་སྐད་, *rgyagar skad*), by which may be understood the *Pracrita* or dialect of *Magadha*, the principal seat of the Buddhist faith in India at the period.

These Books contain the doctrine of SHÁKYA, a *Buddha*, who is supposed by the generality of Tibetan authors to have lived about one thousand years before the beginning of the Christian era. They were compiled at three different times, in three different places, in ancient India. First, immediately after the death of SHÁKYA; afterwards, in the time of ASHOKA a celebrated king, whose residence was at *Pataliputra*, one hundred and ten years after the decease of SHÁKYA. And, lastly, in the time of KANIS'KA, a king in the north of India, upwards of four hundred years from SHÁKYA; when his followers had separated themselves into eighteen sects, under four principal divisions, of which the names both Sanscrit and Tibetan, are recorded.\*

---

\* See p. 25 in the Life of SHÁKYA, in the *Ká-gyur* collection.

The first compilers were three individuals of his (SHÁKYA'S) principal disciples. "UPÁLÍ" (in Tib. "NYE'-VÁR-hKHOR") compiled the "*Vinaya Sútram*" (Tib. *Dul-vé-do*); ANANDA (Tib. "KUN-dGÁVO") the *Sútrantah* (Tib. the *Do* class); And "KÁSHYAPA" (Tib. "HOT-SRUNG") the *Prajnyá-páramitá* (Tib. *Sher-ch'hin*). These several works were imported into Tibet, and translated there between the seventh and thirteenth centuries of our era, but mostly in the ninth. The edition of the *Ká-gyur* in the Asiatic Society's possession appears to have been printed with the very wooden types that are mentioned as having been prepared in 1731 of the last century; and which are still in continual use, at *Snár-t'hang*, a large building or monastery, not far from *Teshi-lhun-po*, (བས་ཤིས་ལྷུན་པོ་, *bkra-shis lhun-po*.)

The *Ká-gyur* collection comprises the seven following great divisions, which are in fact distinct works.

- I. *Dul-vá*, དུལ་བ་, (Sans. *Vinaya*) or, "Discipline," in 13 volumes.
  - II. *Sher-ch'hin*, ཤེར་ཅིན་, (Sans. *Prajnyá-páramitá*) or, "Transcendental Wisdom," in 21 volumes.
  - III. *P'hal-ch'hen*, ཕམ་ཅེན་, (Sans. *Buddha-vata sangá*) or, "Bauddha Community," in 6 volumes.
  - IV. *D,kon-séks*, དཀོན་གཟུངས་, (Sans. *Ratnakúta*) or, "Gems heaped up," in 6 volumes.
  - V. *Do-dé*, མདོ་དེ་, (Sans. *Sútranta*) "Aphorisms" or Tracts, in 30 volumes.
  - VI. *Nyang-dás*, རྟན་འདས་, (Sans. *Nirvána*) "Deliverance from pain," in 2 volumes.
  - VII. *Gyut*, རྟུན་, (Sans. *Tantra*) "Mystical Doctrine, Charms," in 22 volumes, forming altogether exactly one hundred volumes.
- The whole *Ká-gyur* collection is very frequently alluded to under the name, *Dé-not-sum*, དེ་མེད་སུམ་, in Sanscrit *Tripitakáh*, the "free vessels or repositories", comprehending under this appellation—1st. The *Dulva*.—2ndly. The *Do*, with the *P'hal-ch'hen*, *Kon-séks*, *Nyangdas* and the *Gyut*.

—3rdly. The *Sher-ch,hin*, with all its divisions or abridgments. This triple division is expressed by these names: 1. *Dulvá*, (Sans. *Vinaya*). 2. *Do*, (Sans. *Sútra*). 3. *Ch'hos-non-pa*, ཚེས་མདོ་པ་, (San. *Abhidharmáh.*) This last is expressed in Tibetan also by *Non-pa-dsot*, མདོ་པ་མཚོད་, by *Yum*, ཡམ, and by *Ma-mo*. མ་མོ, It is the common or vulgar opinion that the *Dulva* is a cure against cupidity or lust; the *Do*, against iracundy or passion; and the *Ch'hos-non-pa*, against ignorance.

The *DULVÁ*, འཇུག་པ་, Sans. *Vinaya*, which will form the subject of the present analysis, treats generally on the religious Discipline or Education of religious persons. The following are the subdivisions of this Work:

1. *Dul-vá-zhi*,\* (འཇུག་པ་གཞི,) Sans. *Vinaya-Vastu*. Eng. "The basis of discipline or education," in 4 volumes.

2. *So-sor-t'har-pé-do*, (སོ་སོར་ཐར་པའི་མདོ,) Sans. *Pratimoksha Sútra*. Eng. "A Sútra on emancipation," in 30 leaves.

3. *Dul-vá-nám-pár-jét-pá*, (འཇུག་པ་རྣམ་པར་འཇུག་པ,) Sans. *Vinaya vibhága*. Eng. "Explanation of education," in 4 volumes.

4. *Gé-long-mé-so-sor-t'har-pé-do*, (དེ་ལོ་ལོང་མའི་སོ་སོར་ཐར་པའི་མདོ,) Sans. *Bhikshuni pratimoksha Sútra*. Eng. "A Sútra on emancipation for the Priestesses or Nuns," in 36 leaves.

5. *Gé-long-mé-dul-vá-nam-par-jét-pa*, (དེ་ལོ་ལོང་མའི་འཇུག་པ་རྣམ་པར་འཇུག་པ,) Sans. *Bhikshuni Vinaya vibhága*. Eng. "Explanation of the discipline or education of the Priestesses or Nuns," in 1 volume with the preceding tract.

6. *Dul-vá-p'hrán-ts'hégs-kyi-zhi*, (འཇུག་པ་ཕྱན་ཚུགས་ཏྲི་གཞི,) Sans. *Vinaya kshudraka Vastu*. Eng. "Miscellaneous minutiae concerning religious discipline," in 2 volumes.

7. *Dul-vá-zhung-lámá*, (འཇུག་པ་གཞུང་ལྷ་མ་,) Sans. *Vinaya Uttara grantha*. Eng. "The chief text book (or the last work of the *Dulva* class) on education," in 2 volumes.

---

\* In these names the *mute* letters of the Tibetan are omitted for facility of pronunciation: those who can consult the original names will readily supply them where the exact orthography is required. In other places, where a roman letter precedes a syllable in italics, or vice versa, such initial will be understood to be mute.

Some make only four divisions of the whole *Dulvá*, thus, in Sanscrit—  
 1. *Vinaya Vastu*. 2. *Pratimoksha Sūtra* and *Vinaya vibhāga*. 3. *Vinaya kshudraka Vastu*, and 4. *Vinaya Uttara grantha*. And this division is called *Lung-dé-zhi*, (ལུང་དེ་ཟི།,) the four classes of precepts. But in the collection with the Society the subdivision is as exhibited above.

Under this title “*Dulva*” (འདུལ་བ།) there are thirteen volumes marked with the thirteen first letters of the Tib. Alphabet (from ཀ—པ།) On each leaf, on the margin of the left side, whence the lines begin, this title is expressed ; then follows the letter, under which the volume is registered, accompanied by the number of that leaf in words, thus—འདུལ་བ།, ཀ, ཀ་ཟི།, i. e. the *Dulvá* class, the *Ká* or first volume, first leaf.

On the first page are seen three images representing SHÁKYA with his son on his left, and one of his principal disciples on his right, with these sentences or inscriptions below them—“*t’hup-dváng-la namo*,” salutation to the prince of *Munis*—“*Shárihi-pula-namo*,” salutation to the son of SHÁRIKÁ, *sgra-gchen-hdsin-la-námo*,” salutation to GRACHEN DSFN (OR LÁHULA, in Sanscrit.)

The titles of the great divisions of the *Káh-gyur*, and of some particular works, are frequently entitled both in Sanscrit and Tibetan, as in the example just given རྗེ་གར་སྐད་ཅུ།, *rgya-gar-skad-du*, (in the Indian or *Magadha* language, or Sanscrit *Vinaya vastu*.)—*Bod-skaddu*, and lastly in the Tibetan language *hdul-va-gzhi*, འདུལ་བ་གཟི།, “the basis of religious discipline.”

After the title of the work, follows the “salutation to the three holy ones,” in Tibetan, thus—*Dkon-Mch’hog-Qsum-la-p’hyag-Hts’hal-lo*, which in Sanscrit is expressed elsewhere thus—*Namo Ratna Trayáya*, and means exactly what is above expressed. Then follows a special salutation to SHÁKYA, in one *slóka*, of which the meaning is this—“He that has cut off entirely all bonds (of human affection), has overcome the determinists (Sans. *Tirthika*, Tib. *Mu-stegs-chan*.) and has really subdued the devil with all his hosts, he has found the supreme perfection (*Bodhisatwa*.) I adore him.”

I proceed now to take a view of the contents of the several divisions of the *Dulva* class.

The first, Tib. H, *dul-va-Q, zhi* (Sans. *Vinaya vastu!*) "basis of education," consists of several treatises on the disciplining of those religious persons who became followers of SHÁKYA, and entered into the religious order of that *Buddha* or Sage. Besides many others, seventeen such treatises are contained in the first four volumes of the *Dulva* class. The contents may be conveniently arranged with reference to the volume of the class, and the leaf of that volume, in which they are found.

ᳵ, or *first volume of the Dulva class.*

On the second leaf the subjects of the Essays in this class are expressed in two *ślokas*, the meaning of which is this—1. The entering into the religious order. 2. Confession or general supplication. 3. Prohibition or censure of immoral actions. 4. The passing of the summer at a certain place. 5. Leather, hide or skin. 6. Medicament, garments or clothes. 8. Mat. 9. *Kaushámbi*, (a city). 10. Works. 11. *Dmarser-chan*. 12. The inward man. 13. Alteration. 14. The omission or leaving off of the celebration of the feast of confession. 15. Bedding and furniture. 16. Disputing. 17. The causing of divisions amongst the priests.

The contents of the first article are thus specified—" *Sháriki-bu*," or the son of SHÁRIKÁ. *Mustegs-chan*, or *Tirthika* (a determinist?) Two young priests or monks. The murder of an *Arhan*. One with a maimed hand, &c. or all these contents are reduced thus—the son of SHÁRIKÁ (Sans. *Sháriputra*); holy order; ordination, or consecration of priests.

NYE-s, DE (Sans. UPASE'NA) and other bands of religious persons adopt the doctrine of SHÁKYA, become his disciples, and follow him whithersoever he goes.

From leaf 2 to 10 is related how the kings of *Anga* (or *Angadha*) and *Magadha*, made incursions into the territories of each other with troops composed of such as fought from elephants, horses, chariots, and on foot, when SHÁKYA was not yet descended from the paradise of the gods.

The king of *Anga* (whose capital was *Champa*) conquers PADMA CH'HEN-PO, the king of *Magadha* (whose capital was *Rájagriha*) and makes him his tributary ;—haughty expressions of the king of *Anga* in his letter to PADMA CH'HEN-PO ;—the officers of this monarch advise him to surrender to the king of *Anga*, and repeat before him a *śloka*, to this meaning—“ When one's kingdom and life are both in danger, one should have most care for one's life—for on consideration it will be evident that one may find another kingdom but not another life.” The king of *Anga* keeps afterwards *Magadha*, for several years, in subjection, and his publicans, or tax-gatherers, make great exactions there.

An earthquake and a great light are stated to occur at the descent of SHÁKYA, when he enters the womb of his mother, (*leaf 4*.) and again at his birth ;—names of the four kings in the four capitals of central India, and of their sons, that were born at the same time with SHÁKYA ;—why such names were given to those young princes, (*leaf 5*.)

In *Magadha* the young prince born to “ PADMA CH'HEN-PO ” is called in Tib. “ *Qzugs-chan-snying-po* ” (Sans. *Vimbasára*) ;—why so called ;—his eight nurses (Sans. *Dhàtrí*), two for holding him in their laps, two for suckling him, two for cleansing him, and two for playing with him. There were born in *Magadha* at the same time with this prince the sons of five hundred officers.

VIMBASÁRA, when grown up is well practised in all arts, whence his surname (*leaf 5-6*) in Tib. “ *Bzo-sbyangs*,” (Sans. *Shrenika* or *Shrenya*.)—He takes notice of the tax-gatherers of the king of *Anga*, prohibits them from collecting any further tribute in *Magadha*.—They have recourse to the father of the young prince, who permits to continue gathering the tribute or tax in the same manner as before. Afterwards the young prince, finding them again collecting the taxes, menaces them, and orders them to cease absolutely from all tax-gathering. They go to the king of *Anga*, tell him how they have been treated by the young prince of *Magadha*, and repeat before him a *śloka* of this meaning, “ As long as a tree is young it

can be cut off with the nails of the fingers ; when it has grown large it is difficult to cut it down even with a hundred axes." The king of *Anga* sends his envoys or messengers to the king of *Magadha*, and demands of him that the young prince, tied by the neck, should be sent to him ;—an answer is returned to him ;—they both prepare for war.

The king of *Magadha* appoints his son commander of the army. VIMBASÁRA summons those five hundred sons of officers that were born at the same time with him ;—acquaints them with his own circumstances ;—tells them that he is resolved to make war against the king of *Anga* ;—appoints them his officers. They all cheerfully engage in his cause, and assure him that his circumstances will be their own. The prince utters a *śloka*, of which the meaning is this : " In whose house there is renown and glory (or a sacred person) it must be defended by all means. When honor is lost all is gone ; as when the nave of a wheel is broken, the spokes are of no use." The officers assure him of their attachment to him in these words : " where your feet are there are our heads." He assembles the four kinds of troops. His father expresses his wonder at the great number of his son's army—thence VIMBASÁRA's surname " the king that has many troops." Since the king of *Anga* had yet more troops than he himself—he causes him to be slain by a stratagem. He occupies afterwards the whole of *Anga*, and takes up his residence at *Champa* till the death of his father. Afterwards he makes his residence at *Rājagriha*, and this VIMBASÁRA is represented in the *Dulva* as the king of *Magadha* in the time of SHÁKYA, whom he greatly esteemed, honored, and patronized.

From leaf 10. A young Brahman from *Magadha*, or Central India, travels towards the south of India, searching after mysteries or the *Tantrika* doctrine. He goes to a celebrated Brahman ;—is well received by him ;—general reflections on the character of the people in the east, south, west and north of India. Praise bestowed on Central India, (*leaf* 10-11.) Many wish to see it. A celebrated Brahman goes with the former to *Rājagriha* ;—pays there a visit to the king ;—desires to dispute with any one of the brahmins

in *Magadha*;—the king calls on a certain (*QNAS-LEN-GYI-BU*) brahman of *Nalada*, a learned man who overcomes him in a dispute; the king is greatly satisfied with it, makes him a donation of *Nalada*, his native place or town; (*leaf 13.*) He returns to *Nalada*;—marries;—after nine months his wife is delivered of a son, who is named “*STOD-RINGS*”—why so—is entrusted to eight nurses, (*leaf 13.*)—when grown up, is well instructed in all the arts and sciences, (*leaf 14.*) in the *Rigvèda*, *Yajurvèda*, *Sàmavèda*, *Atharvavèda*, &c. Afterwards his wife is delivered of a daughter, who having eyes like those of the *Shàriká* bird, is called *SHÁRIKÁ*—she is instructed in the letters,—overcomes her brother in a dispute.

Again, a certain Brahman desirous to be acquainted with the *Tantrika* doctrine, or with mysteries,—travels from Central India towards the south;—is instructed there in the *Lokàyata* system, by a learned Brahman “*SKAR-RGYAL*” (*Sans. TIS’HYA.*) Reflections on the characters of the people of the four corners of India, and the praise of Central India, (in the same terms as above.) This *SKAR-RGYAL* wishing to visit Central India, successively goes to *Rájagriha*,—pays there a visit to the king,—requests him for his patronage, and expresses his wish for disputing with any learned Brahman,—the king calls on “*QNAS-LEN-GYI-BU*” of *Nalada* (or *Nalanda*). *SKAR-RGYAL* defeats him in a dispute, and he is consequently deprived of *Nalada*, which village is conferred by the king to his successful adversary;—the former is much grieved, and is about to leave *Nalada*, and go to another place—when *SKAR-RGYAL* cedes one half of his income to him, that he might remain there;—he accepts of it, remains, and gives his daughter to *SKAR-RGYAL* for his wife.

*Leaf 18.* *STOD-RINGS*, the brother of *SHÁRIKÁ*, travels towards the south of India to learn the *Lokàyata* philosophical system. As a layman he is not admitted to hear that philosophy;—he enters into the religious order of the *Kun-tu-rgyu* (going every where) *Sans. Parivràjaka*,—will not cut his nails till he has learned that philosophy,—thence he is surnamed afterwards, *SEN-RINGS* (he with long nails, or the long nailed.)



*Leaf 19.* SHÁRIKÁ enters into a dispute with her husband, SKAR-RGYAL: she is overcome. She becomes pregnant with a child of wonderful character,—her dreams,—explication of her dreams. She disputes again with her husband—now she overcomes him; this is attributed to the wonderful child in her womb;—she is delivered of that child;—it has several tokens on his body of being imbued with extraordinary qualities. After the name of his father, he is called NYE'-RGYAL, (Sans. *Upatis'hya*); after that of his mother, SHÁRIKÁ's son (Sans. *Sháriputra*, Tib. *Shárihi-bu*) (*leaf 20.*) His qualifications in all the branches of science, and the practices of the brahmans. He excels his father in understanding the true meaning of the text of the ancient brahmanical works, (*leaf 21.*)

From *leaf 22.* The history of MOHUGAL-GYI-BU, or *Mōngal-gyi-bu* (Sans. MAUGALYANA). His father's name, residing place and rank. He (the father) marries,—desirous to have a son,—addresses his prayers to all sorts of gods:—at last he obtains one:—sagacity of women with child in distinguishing whether that child be a male or female;—precautions which the minister takes with respect to the diet of his wife,—tastes and savours of meat and drink enumerated:—she is delivered of a child with a perfect body;—the child is called "*Lap-born*,"—why so? and also "*Mōngalyana*," and why so? Hence he is called sometimes, Tib. *Pāng-skyés*, *Lap-born*, Sans. "*Kolita*," sometimes Tib. *Mohugal-gyi-bu*, Sans. *Mōngalyana*, one of the *Mōngol* family or race. His nurses, his education, his qualifications in all the sciences and practices of the brahmans, (*leaf 24.*) He surpasses his father in understanding the true meaning of the ancient works. He is entrusted with the instruction of 500 young brahmans in reading the brahmanical works. How they pass the time when they are not reading. The two masters or teachers NYE'-RGYAL (Sans. UPATIS'HYA) and PANG-SKYES (Sans. KOLITA) acquire great renown by their disciples,—they are desirous to see each other. The first is very ingenious or intelligent, the latter very rich. Their parents will not permit them to go and see each other. They meet at the occasion of a festival at *Rājagriha*, whither they

were sent by their parents. They sit near to each other. Their behaviour during the several exhibitions of spectacles;—their mutual addresses, after the shows are over;—their answers, each in a single stanza, (*leaf 28.*) They acquire an affection for each other; eager to acquire knowledge, they resolve to enter into some religious order. PANG-SKYES begs his parents to permit him to take the religious character; he is not permitted. His parents, his relations, his coetaneous friends use several arguments to dissuade him from his purpose; they cannot prevail on him. He will absolutely not partake of any repast until he is permitted. At last he obtains his parents' leave, goes to *Nalada* to meet there "NYE'-RGYAL," who very easily obtains his parents' leave to take the religious character;—reflections thereupon by PANG-SKYES (*leaf 33.*) They proceed together to *Rájagriha*, where about that time there are supposed to have been six celebrated teachers, the masters of six schools of different principles (whose names both Sanscrit and Tibetan are on record). Successively they go before each of them, address them each in these terms: "Master? (*shes-ldan*, knowing) what is the method of your doctrine? what advice do you give to your pupil? what is the fruit of an honest life? (or of good moral practices) what are the benefits thereof?" Each master addresses them thus: Brahman-sons! and each tells them his own opinion or principles:—they are with none of them satisfied: they make on each their reflections in the same terms, in one stanza, the meaning of which is this: "He is an ill minded, wrong teaching, and mean fellow, although he is celebrated for a master: if his own professed principles are such, what are those which he does not profess." They leave them with disdain or contempt, on account of their gross atheistical principles. (The names and philosophical principles of those six teachers or masters may be seen, from *leaf 33 to 40* of the १, or first volume of the *Dulva.*)

*Leaf 40.* They become afterwards the pupils of "YANG-DAG-RGYAL-VA-CHAN." He entrusts them with the instruction of his five hundred disciples. In his sickness, these two young brahmans make every effort

to assist him. The one attends on him, the other seeks after medicaments. The cause of his smiling once. He tells them the birth of SHÁKYA, and that he has become a saint or *Buddha*. He advises them to become his disciples, but not to mention their caste and family name, but leaving off every pride, to practise good morals before him, if they wish to find the food of immortality (Tib. *Bdud-rtsi*, Sans. *Amrita*.) *Leaf 41*. A stanza on the instability of human things: "All gathered treasures will end in want; the end of those on high is downfall; the end of meeting is separation or parting; the end of being alive is being dead (or is death)."—He dies—they burn his body decently, and mourn for him. They are convinced that their deceased master has been a sage, and that he had found the food of immortality. They regret much that he has not communicated it to them. They both make a law among themselves, that whichever should find first the *amrita* should communicate it to the other. The circumstances of their afterwards becoming disciples of SHÁKYA. He declares them the first pair of his principal disciples,—NVE'-RGYAL (SHÁRIHI-BU, or SHÁRADWATI) "the chief of the ingenious or intelligent," and PÁNG-SKYES (MONGAL-GYI-BU, or MOHUGAL-GYI-BU, Sans. *Mongalyana*) "the chief of those that make miracles or prodigies or illusory spectacles."

*Leaf 42*. SHÁKYA declares that his privation and austerities, during the course of six years, were to no effect; he could not find what he sought for. He refreshes himself with substantial food, recovers his vigour, gives himself to meditation, and arrives at perfection, or becomes a *Buddha*. On the request of BRAHMA, the god, he goes to *Varánasi*, performs there his first religious course, teaches his doctrine first to five men, who had been formerly his attendants. Afterwards he disciplines there fifty young persons of high descent;—ordains and consecrates them, (*leaf 43*.) At other different places he finds many other disciples;—goes to *Rájagriha*. The king of *Magadha* (VIMBASÁRA) offers him a residing place in a grove (called འོད་མའི་ཚྭ་ཅུ་མ་ལན་དུ་གཤི་བཞག་, *hod-mahi-ts'hal.byakalan-*

*da-kahi-gnas.* Sans. *Vēnu-vanam Kalandakā nivāsa.*) It is there that the above described NYE'-RGYAL and PANG-SKYES become his disciples.

*Leaf 44-45.* Enumeration of several qualifications of SHĀKYA—his seeing and knowing all things. The method he used in bringing to his doctrine or faith the before mentioned two young brahmans;—farther circumstances thereof, (*leaf 45-50.*)

Having been told by one of SHĀKYA's disciples that he teaches in this manner: "What things are they that arise from causes, and what are the causes of their existence and of their cessation?"\* these young brahmans are much pleased with, and go to, him, to become his disciples, *leaf 50.* Rumours at *Rājagriha* upon hearing that the two principal disciples of YANG-DAG-RGYAL-VA-CHAN have become the followers of SHĀKYA.

*Leaf 51.* KUNTU-RGYU SEN-RINGS (a brahman learned in the *Lokāyata* philosophical system) pays a visit to SHĀKYA;—is very impatient at first,—afterwards, being convinced by SHĀKYA of his wrong principles, he yields, and begs him to receive him into his order, *leaf 57.*—Terms used by the new comer and by the master at entering and at receiving one into the religious order.

*Leaf 58-65.* On the enquiry of the priests, how it came that "SHĀRIHI-BU possesses such admirable talents?—SHĀKYA tells them his religious and moral merits in his former generations. *Leaf 65.*—Likewise, he tells them those of MOHUGAL-GYI-BU.

*Leaf 68.* SHĀKYA commits to the assembled body of the priests the power of receiving neophytes into his religious order, and to ordain priests when qualified. Many inconveniences arising from there being no Head or President in the congregation of the priests;—regulations for electing two principals (*Mk'han-po*), and five sorts of teachers (*Slob-Dpon vulgo Lobon.*) Rules to be observed. Instruction how to perform the rites

---

\* *Ye dharmā hetu prabhavā, hetu teshān TATHĀGATO hyavadat—Teshan cha yo nirodha, evam vadi MAHĀ SRAMANAS.*—Of this formula, which is found on most of the images of *Buddha* dug up at Benares, in Tirhut, and elsewhere, a full account has been given in the *Journal Asiatic Society*, Vol. IV. page 133 and 211.

and ceremonies at the receiving and ordaining of the priests. Terms used at that occasion.

What sorts of men may be received into the religious order, and admitted to become priests. Questions to which a new comer must answer directly. Names of several diseases and sores, *leaf 79*. Persons infected with, or subject to those maladies are prohibited from admission into the order. Several rules respecting the conduct of religious persons.

*Leaf 91*. A priest should not abuse any one (in words) even when himself abused; should not become angry when irritated; should not beat when beaten; nor rail when railed.

*Leaf 92*. Enumeration of several things which a religious person or priest may not do without having previously asked the principal's and the teacher's leave.

*Leaf 102*. SHĀKYA having passed the three months of the summer in the grove near *Rājagriha*, will make a tour to the hills towards the south. He makes known to the priests, that whoever likes may go with him. Excuses of the priests, both of the old and young, for not being able to accompany him. Cause or reason why but a few disciples were now with him.

*Leaf 104*. How any *Mu-stegs-chan* (Sans. *Tirthika*) may be admitted into the religious order of SHĀKYA. Regulations thereupon.

*Leaf 108*. No priest is to be ordained that is below twenty years of age. Reasons thereof.

*Leaf 109*. No one shall be received into the religious order below fifteen years of age. Indecent conduct of two young priests or students.

SHĀKYA at *Shrāvasti* in *Kosala*. The story of two slaves or servants, who successively had been received into the religious order of SHĀKYA.

*Leaf 110-113*. No slaves are to be admitted into that order.

*Leaf 113-115*. Stories of two persons who, being in debt, had taken the religious character. SHĀKYA prohibits the admission into the religious order of any one who is in debt.

*Leaf 115.* The story of a young man who, having run away from his parents, had entered into the religious order. SHĀKYA refuses to admit any one into that order without the consent of his parents. Regulations thereupon.

*Leaf 116.* The story of a young person who had been received into the religious order of SHĀKYA by a high priest. Resolution—not to receive any one without the consent of the whole congregation of the priests.

*Leaf 118-121.* The story of a sick person; no sick man is to be received into the religious order. Every new comer to be questioned as to the state of his health.

*Leaf 121.* SHĀKYA in the *Nyagrodha Vihar*, near *Capila* (*Ser-skyā*, in Tibetan.) Great lamentation of the women of *Capila*, upon their fathers' husbands, brothers, &c. taking the religious character and leaving their houses. ZAS-GTANG-MA'S (Sans. *Sudhodāna*, the father of SHĀKYA,) complaint before SHĀKYA. He again prohibits their receiving any one into the religious order without the consent of his parents, and orders that they should always ask first whether a candidate has leave from his parents, except in cases of those, who have come from a far country. *Leaf 123.*

*Leaf 123-127.* The story of KUN-DGAH-VO'S (Sans. *A'NANDA*) sister's two children. How they were encouraged to read and study diligently.

*Leaf 127-133.* Several births according to one's moral or religious merits, described by SHĀKYA,—applied to the beforementioned students or young monks.

*Leaf 133.* The wonderful effects of SHĀKYA'S smiling. Reasons thereof. Order prohibiting the seduction of nuns or of priestesses by the monks or priests.

*Leaf 136.* A man passing clandestinely some time amongst the priests, without having been admitted regularly, is made acquainted with their doctrine and religious practices. His reflections thereupon. Scandals arising therefrom. SHĀKYA'S order for ejecting or expelling him, and not to suffer afterwards any one to cohabit clandestinely with the priests. *Leaf 138.*

*Leaf 138-139.* SHÁKYA at *Mnyan-yod* (Sans. *Shrāvasti*, in *Kosala*). Several kinds of men of doubtful sex, or of hermaphrodites (Tib. *Máning*). Prohibition against receiving any such into their religious order. They should always ask when receiving a newcomer whether he is a *Máning*.

*Leaf 139.* SHÁKYA at *Shrāvasti*. The story of an illusory serpent. (Tib. *Klu*, Sans. *Nága*).

*Leaf 142.* Prohibition against receiving into the religious order any illusory man (*Sprul-pá*.) Thenceforth they shall always ask when admitting one into the religious order, whether he is a *Sprul-pa*.—Five kinds of natural *Nágas*;—the rest all illusory ones.

*Leaf 143-145.* Good services rendered by an illusory *Nága*, to several religious persons. The priests should distinguish an illusory monastery from a real one, and not resort to such places.

*Leaf 147.* SHÁKYA forbids the giving religious instruction to any one, unless asked; except when one is invited to a public entertainment.

*Leaf 147-163.* The story of *DGE-HDUN-HTS'HO*. His birth—his beautiful body—his becoming the attendant of SHÁRIHI-BU—his accomplishments—his accompanying five hundred merchants to the sea—his great services and religious instructions to many. Marvellous stories of *Nágas*, &c.

*Leaf 163.* The way of the ancient sages discovered by SHÁKYA, illustrated by a parable. Description of that way or method.

*Leaf 167.* *DGE-HDUN-HTS'HO* returns to SHÁKYA—presents his converts, they are received by him into his religious order—the great perfection they acquire afterwards by their assiduity and earnest endeavour.

*Leaf 168.* At the request of *DGE-HDUN-HTS'HO*, SHÁKYA relates what have been the actions in former lives of several individuals whom he had found deficient in virtue, and monsters of iniquity.

*Leaf 170.* Again, on the request of the priests in a body, SHÁKYA relates the religious and moral merits of *DGE-HDUN-HTS'HO*.

*Leaf 172.* The story of “*KLU-GZHON-NU-SPRUL-PA-HOD-SRUNG*” (Sans. *KĀSHYAPA*). An ancient *Buddha*, living at *Varānasi*, instructs his disciples where to perform their meditations; and advises them to live such a chaste and pure life that they may not repent it afterwards. The disciples of *SHĀKYA* will imitate those of *KĀSHYAPA* in performing their meditations—they commit many excesses;—restrictions and prohibitions thereupon.

*Leaf 175.* *SHĀKYA* at *Mnyan-yod* (Sans. *Shrāvasti*) A *Mu-stègs-chan* monk (Sans. *Tirthika*) once, on the 14th of the month, on the confession day of the Buddhists, enters into their *Vihar*, admires their furniture and the mode of living, and says: “The Buddhists excel us in furniture (or household stuff) and in good fare; but we excel them in religion and good morals.”—To enjoy both in their proper places he purposes to make profession of both religions;—is detected and expelled. A rule is established, that thenceforth no one shall be admitted into the order, who had become formerly a *Tirthika* (*Mu-stègs-pa*, in Tibetan) or a brahmanist in general.

*Leaf 177.* *SHĀKYA* at *Mnyan-yod* (Sans. *Shrāvasti*.) The murder of a mother;—the circumstances preceding and following it:—various advice given to the matricide by the *Tirthikas* (that he should throw himself into fire,—take or swallow poison,—precipitate himself from a steep place, or strangle himself by a rope.) In his confusion, he takes refuge in the monastery of *SHĀKYA*’s disciples; hears there accidentally from the mouth of a priest reading, that “he who opposes good actions to a committed crime, may shine even in this world like the sun and moon, after having escaped from a cloud.” He repents, and, that he may yet efface the horrors of his crime by good actions, he resolves to take the religious character:—he does so, and, in a short time by his earnest application, he arrives at great perfection. *SHĀKYA* is informed by the priests of his being a matricide, orders him to be expelled, and makes a rule that no matricide is to be admitted into that order; and that thenceforth they should always



ask a new comer whether he is a murderer of his mother. The farther adventures of the same matricide related ;—his death and his new birth, first in hell, (*leaf* 179,) and afterwards in heaven amongst the gods.

*Leaf* 183 to 188. The murder of a father ;—circumstances that preceded and followed it, (told in the same manner, and nearly in the same words as above, in regard to the murder of a mother.)

*Leaf* 188. SHÁKYA at *Mnyàn-yod* (Sans. *Shrāvasti*.) The edicts of the kings of *Magadha* and *Kosala* (when they adopted Buddhism) that in their realms no robbery should be committed. Robbers, if detected, are to be expelled from their country, and restoration of damage to be made from the king's treasury. Robberies and murders committed on the confines of *Magadha* and *Kosala* :—some traders, that have escaped, go to the king of *Kosala*, and inform him of the event :—the king sends his troops ; the robbers are defeated ; some escape ; some are killed ; sixty taken alive and brought to the king, together with the things and effects found with them. The examination of the robbers by the king—their answers. They are put to death, one escapes when carried to the place of execution, takes his refuge in a monastery of the priests of SHÁKYA, enters into the religious order. He is found afterwards to have been a robber, and the murderer of an *Arhan* (Saint.) The circumstances of that detection ;—a rule is made that thenceforth no murderer of an *Arhan* shall be received into the religious order, and that they shall ask of every new comer whether he is a murderer of an *Arhan*.

*Leaf* 190. NYE'-VÁR-HK'HOR (Sans. UPÁLI) asks of SHÁKYA whether one, who has caused divisions amongst the priests, is to be received into their religious order. No such shall be admitted :—likewise, no one shall be received into the order, who with an ill intention to a *Tathágata* has shed blood ;—nor any that may previously have fallen off, by having committed any of the four great crimes.

*Leaf* 191. All such persons as have any defect in their body, members or limbs, are prohibited from admission into the religious order of

SHÁKYA. They are thus specified: one with a maimed hand or foot, one without lips, one having a cicatrized body, too old, too young, lame or cripple, blind, having maimed fingers, crooked, a dwarf, having a goitre, dumb, deaf, leaning on a staff in walking, creeping or crawling, having swollen feet with corrupt matter in them, effeminate, broken under burden or by much travelling, &c. *leaf* 193.

With this concludes the subject of entering into the religious order of SHÁKYA, entitled in Tib. the རབ་ཏུ་བྱུང་བའི་གཞི *rab-tu-byung-vahi-Gzhi*, Sans. *Pravrajita vāstu*.

From *leaf* 193 to 335, inclusive, is occupied with the description of the གསེས་བྱུང་ *Gso-sbyong*, confession or self-emendation, and general supplication. SHÁKYA at *Rājagriha*. The celebration of the confession, or general supplication at the end of every half month, i. e. at every new and full moon:—occasion of its being ordained,—preparations thereto;—rites and ceremonies thereof, *leaf* 195. Explanation of the term *hdug-pa*, འདུག་པ་, sitting, and meditating, or abstract meditation, (རྣམ་འཕྲུལ་ *rnal-hbyor*.) The priests of SHÁKYA carry to excess the giving themselves to abstract meditation. *leaf* 201. Five sorts of *ghantis* (plates of mixed metal to be struck instead of bells)—for what use. *leaf* 202. Praying and the recitation of the *Pratimoksha Sūtra*, or *So-sor-t'har-pahi-mdo*.

The great court-yard for the celebration of the feast of confession. CAPINA, a brahman. His scruples about whether he should go or not to that festival. On the exhortation of SHÁKYA he goes there. Designation of the place for the reception of the great congregation. The officiating priest. The terms he uses in addressing the priesthood. Garbs or garments which the priests are permitted to take with them into the congregation. Description of the smaller court-yard or enclosure, *leaf* 219. Instructions for reciting the *Pratimoksha Sūtra* (or the tract on emancipation). How to intercede for any priest who may have been arrested or taken, on this day, by the king, by the robbers, or by the enemy. Then follow several instructions, how to celebrate this great day

of confession elsewhere, *leaf* 335. And thus ends the second part of the *Vinaya vāstu*, on confession or general supplication.

From *leaf* 335 to 357 is the *Dgag-dvyéhi-Gzhi* དགག་དབྱེའི་གཞི།. The enumeration of immoral acts or faults. Censure thereof. Reproof and prohibition of immoral actions. A reprover or censor is elected for that purpose. Several instructions given, how to perform the office of a reprover or censor of manners, rites and ceremonies.

From *leaf* 357 to 378 is the *Dvyar-gyi-Gzhi* དབྱར་གྱི་གཞི།. On summering, or passing the summer. SHÁKYA at *Mnyán-yod* (Sans. *Shrāvastī*). The occasion of establishing the custom of making a vow for passing the three months of the summer at a certain place, without leaving it even for a single night—for what purpose it was ordained. Several instructions, concessions, restitutions, and exceptions. The manner in which they passed that season. Mutual compliments after the return of the priests to their respective colleges or monasteries. Several questions and answers how they have passed the summer.

From *leaf* 378 to 408, or the end of this volume, and in the beginning of the next volume (from *leaf* 1 to 10), contained the *Ko-lpags-kyi-Gzhi*, མོ་ལཔག་གྱི་གཞི།, or, the subject of leather or skin.

The story of GRO-BZHIN-SKYES, his birth, his growing up, his voyage at sea:—is received into the religious order by KÁTYĀNA (residing at ར་ཇན་ *Rdo-chan*);—arrives at great perfection, (*leaf* 396.) Several sorts of skin or leather are enumerated. His private audience at SHÁKYA'S. KÁTYĀNA'S complimentary address to SHÁKYA, presented by him:—SHÁKYA'S answer thereto, *leaf* 405. Permission (to the disciples of SHÁKYA) to use a vehicle or carriage;—the occasion or circumstance of that permission;—excesses in the use of carriages;—they are prohibited, except to the old, the weak and the sick.

*Leaf* 406. Leave (to the disciples of SHÁKYA) to acquire a practice in swimming;—occasion of that leave being given;—excesses made in that practice. Indecencies committed in the *Ajirapati* river. They are

prohibited from touching any woman ;—they may not save even one that has fallen into the river ;—modification of the former prohibitive precepts.

*Leaf 407.* They are prohibited from seizing a cow by the tail, in swimming over a river ;—occasion thereof. They may seize the tail of a fine elephant, fine horse, bull, buffalo, and yák, but they must at the same time make use of a leather bag (glove?) Improperities committed with the leather bags. They are prohibited from wearing wooden shoes (*shing-gimch'hil-lham*) ;—occasion of that prohibition. They are permitted to wear them in their own houses ;—what was the reason thereof. What to do with the wooden shoes presented (or offered) to them by the people. *Leaf 408.*

The first volume of the *Dulvá* terminates here. Note: The scenes of the transactions it contains, and indeed of the whole *Dulvá*, are represented to have been, with a few exceptions, *Rájagriha* in *Magadha*, and *Shrávasti* in *Kosala*, or more properly the groves near those cities.

#### THE 𑖀 (*Kha*) OR SECOND VOLUME OF THE *Dulvá*.

This volume contains 563 leaves. It is divided into 30 parts or books (བམ་པོ་ *Bam-po*) or from the 25th to the 54th book inclusive.

From *leaf 1* to 10 is the continuation of the *Ko-lpags-Gzhi* མོ་ལྷ་པོ་ལ་ཞུ་བའི་ of the first volume, or the treatise on leather or hide ; or, in general, on the priests being allowed to wear shoes. In the Index, the subject of the whole volume is said to be on medicaments. But there is very little on that subject, except from the 10th to the 40th *leaf*.

From *leaf 1* to 10. Several sorts of shoes (*Mch'hil-lham*) of the religious class are enumerated, together with the stories of their being brought into use and prohibited afterwards by SHÁKYA. Such are those made of reed leaves (*smyug-lo*) ; of the fibres of the *munja* grass ; of thread or yarn (*srad-bu*), &c.

From *leaf 10* to 19. SHÁKYA in the grove near *Shrávasti*. On medicine and drugs prepared from the roots, stalks or stems, leaves, flowers, fruits or nuts, juices or sap, and gums of certain plants and trees. Nuts of an

acid taste, as that of the *Amra* tree, *Arura*, *Skyurura*, and *Parura*. Kinds of salt. Stories of particular diseases and maladies. What sort of medicament was prescribed by the physicians for each disease;—how such medicaments were permitted by SHÁKYA to be used. Permission given by SHÁKYA to his disciples to keep always with them a certain quantity of medicine (previously consecrated or blessed.) What gave occasion to that leave. Medicaments to be used daily, at a certain period of the day, for seven days, through one's whole life:—diet in meat and drink. *Leaf 15*; medicament for the eye. The story of a madman. Stories of particular meat or flesh having been used by the disciples of SHÁKYA, in the time of famine. Prohibitions against such practice.

*Leaf 19.* SHÁKYA enters from *Káshi* into *Varánasi*. The story of a Tribune's (headman's) wife there—her piety and her former moral merits.

*Leaf 27.* The king of *Magadha* (SHRENIKA VIMBASÁRA) pays a visit to SHÁKYA in a grove near *Rájagriha*, and begs his acceptance of an entertainment for three months with every thing necessary for him and his train or suite.

*Leaf 30.* The story of a priest suffering from hemorrhoids (piles) Haughty and malignant behaviour of the king's physician to that person, though he was sent by the king to cure him;—he called SHÁKYA also the son of a female slave. His punishment.

*Leaf 33-34.* Names of the six remarkable places or capitals in Central India, as 1. Tib. *Mnyan-yod*, Sans. *Skrávasti*. 2. Tib. *Gnas-Bchas*, Sans. *Sáketána*. 3. Tib. and Sans. *Varánasi*. 4. Tib. *Yangs-pa-chan*, Sans. *Vaishali*. 5. Tib. and Sans. *Champa*. 6. Tib. *Rgyal-pohi-k'hab*, Sans. *Rájagriha*.

*Leaf 34-35.* What sort of medicament was employed by KUN-ÐGAH-VO (A'NANDA) in curing SHÁKYA in a disease. The story of GANG-PO, *leaf 40*.

*Leaf 80 to 87.* The king of *Magadha* (LUS-HP'HAGS-MAHI-BU-MA-SKYES-DGRA) invites SHÁKYA into *Rájagriha*. With what solemnity he receives

him. The procession of the sage thither together with his train; the order thereof, and to what things it has been likened. Several miracles or prodigies that happened at his entrance into that city.

*Leaf 83.* The king of *Magadha* afterwards pays a visit to SHÁKYA and begs him to accept of an offer of entertainment for himself and suite during the three months of the winter, with all things that should be required (with dresses, a religious garment, meat and drink, beddings, medicaments and utensils.)

*Leaf 83.* SHÁKYA is invited afterwards (on the occasion of an epidemic malady) to *Yangs-pa-chan* (Sans. *Vaishali*, hod. *Allakabad*). A chief man in that city, in a dream, is admonished by the gods, that they should implore the aid of GAUTAMA. They consult about it, and send an embassy to him. At the request of the envoys from *Vaishali*, the king of *Magadha* permits SHÁKYA to visit their city, provided that they shall treat him in the same manner as he has been treated in *Rájagriha*; form of salutation or compliment used by the envoys from *Vaishali*.

*Leaf 120 to 132.* Upon SHÁKYA'S arrival at *Yangs-pa-chan* he is, first of all, invited and entertained by AMRA-SKYONG, a rich courtesan, whose residence was without the city, in a grove. Afterwards he is entertained by the citizens, who were of the *Lichabyi* race; (they seem to have been republicans.) Their splendid dresses, horse furniture, carriages and chariots, &c., &c. This city is frequently compared by SHÁKYA to the residence of the gods, where Indra presides. KUN-DGAH-VO (A'NANDA) directed by SHÁKYA, advancing to the gate of the city, solemnly utters several mantras or set of forms of charms (in Sanscrit) for purifying the city from all evil spirits, and causing to cease the epidemic malady. The charms begin thus: "*Vasirata*" (four times repeated)—"*Munchata*" (twice)—"*Nirgach'hata*" (four times)—&c., and are followed by benedictory verses for the prosperity of the city.

*Leaf 132.* On quitting that city, SHÁKYA passes through several other places in his peregrination, and relates to KUN-DGAH-VO (Sans.

ANANDA) their ancient history—makes several reflections on them, and in many places gives instructions to those that visit him.

From *leaf* 155 to 192, is contained the story of the meeting of PADMA SNYING-PO with SHĀKYA. This celebrated brahman hearing of SHĀKYA'S being in the neighbourhood on his peregrination, sends to him one of his principal disciples (MA-SDUG), of great acquirements, with several old brahmans of respectable character, to learn through them, whether it be true what is rumoured respecting the accomplishments of GAUTAMA, and whether he has really all the characteristic signs of a sage. The conduct of MA-SDUG, and his conversation with SHĀKYA or GAUTAMA. He calls those of the SHĀKYA race upstarts, or such as are known but of late ཏཱ་བྱུང་ *da-byung*,) *leaf* 160. SHĀKYA tells him the origin of the SHĀKYA race, as also that of the family of MA-SDUG. He is much ashamed, and cannot return any answer to SHĀKYA; but is comforted, and afterwards begs for instruction. Then the teacher tells him the tenor and contents of the doctrine of a Buddha; and the several moral duties both of the Brahman and the Bauddha priests, which they should observe and perform religiously. He afterwards relates many superstitious customs, and declares that every true Brahman and Bauddha priest should desist from all such.

After the return of MA-SDUG, PADMA-SNYING-PO hearing of his having been unable to answer GAUTAMA, was so much displeased that he smote him with his shoes on the head, and would have gone immediately himself to GAUTAMA, had it not been too late in the evening. The next day mounting a carriage, and taking with him many prepared victuals, he visits GAUTAMA, is much satisfied with his conversation, and arranges a mode of salutation and return whenever they should happen to meet in the street; He assigns as the reason thereof, that courteous ceremonies are a mode of maintaining respect and renown amongst their followers.

*Leaf* 192. Terms of salutation; those in which men of quality or rank send their compliments, and ask after a friend's health by their messengers or servants. A full enumeration of the terms is given,

in which the King of *Kosala*, GSAL-RQYAL sends his compliments to GAUTAMA. (The catalogue occurs many times in the KA-GYUR, and is also introduced into the Sanscrit and Tibetan Vocabulary.)

*Leaf 193.* The King of *Kosala*, GSAL-RGYAL, pays a visit to GAUTAMA—asks him about several things:—what difference there is between the four castes? GAUTAMA replies to the King so as to lead his own mind to the conclusion, that there is really no difference between the four castes. He asks him afterwards whether there exist gods,—whether the god BRAHMA does really exist?—The answer contains several modifications, and declares, if the king means such gods as have fleshly passions, and which delight in injuring and hurting others, there are none of that kind.

From *leaf 201.* In *Rájagriha*, and in several other places, at different occasions, SHÁKYA gives many moral instructions, citing instances or parables.

From *leaf 214.* The story of YUL-RK'HOR-SKYONG—how he enters into the religious order—his reflections—moral instructions to his parents.

*Leaf 240.* SHÁKYA, accompanied by GNOD-SBYIN-LAG-NARDORJE converts many in the North of India.

*Leaf 290.* Account of DGAH-VO, a neatherd, with five hundred others entering into the religious order.

*Leaf 302.* SHÁKYA, visiting several places, tells to KUN-DGAH-VO their ancient history, and whence they derived their names.

*Leaf 303.* The king GSO-SBYONG-HP'HAGS (Sans. *Utpshadha*) born at Gnas-Bchas (Sans. *Saketana*.)

*Leaf 306.* Terms for expressing great joy (by comparison.)

From *leaf 327 to 390.* Fragments of history of several universal monarchs, (Sans. *Chakravartti*.)

*Leaf 390.* The story of NOR-BZANGS, a royal prince, and of YID-HP'HROG-MA (the heart ravishing) his mistress. This contains many fine poetical descriptions and ingenious verses expressive of an affectionate mind : it is a kind of romance or fairy story.



From *leaf* 408. Several anecdotes are told by SHÁKYA, to show the fruits and consequences of the merits and demerits of several individuals in former generations. He relates to the king of *Kosala* his own acts—how he arrived at *Bodhisatwa*, and the many benefits he afterwards endeavoured to bestow upon all animal beings. This division abounds in judicious sayings, and moral maxims :—apologues or moral tales—their application,—virtue and vice depicted in lively colours.

From *leaf* 496. On the request of KUN-DGAH-VO (A'NANDA,) his principal attendant, addressed to him in verse, SHÁKYA relates (also in verse,) the acts which he has performed from a very remote age to arrive at the state of a *Bodhisatwa*.

*Leaf* 505. SHÁKYA, together with 500 Arhans, visits, in a miraculous manner, the great lake *Ma-dros* (*Manassarovára*) in the north.

*Leaf* 506. The four great rivers that take their rise there :—the *Ganga*, *Sindhu*, *Pakshu*, and *Sita*.

From 508 to 563, or to the end of the volume, as also from *leaf* 1 to 20, in the next or 3d volume. On the bank of the *Ma-dros* lake. SHÁKYA, and 36 persons of his principal disciples, tell (in verse) the course of their lives in former generations—or the consequences of good and bad actions. End of the 2nd volume.

THE 3RD (OR 4) VOLUME OF THE *Dulvá*,

*Comprising 478 leaves, from the 55th to the 82nd book or section, inclusive.*

*General Contents.* The latter part of the subject of “medicaments” in the 2nd volume. On garbs or garments—mats, spreading cloths; *Kau-shambhi*; works or moral actions—*Dmar-ser-chan*, the inward man, or man-alteration (regeneration). Omission or the leaving off, of the celebration of the confession, or general supplication. Dispute or quarrel :—the first part of the subject “of causing divisions amongst the priests.”

From *leaf* 1 to 20. The continuation of SHÁKYA'S narration of his former births. The story of *BZANG-MO* and *PADMA-BTSA-LAG*, a cour-

tezan and her gallant, in the time of the king TS'HANG-SBYIN (Sans. *Brahmadatta*) in *Varánasi*, cited by SHÁKYA and applied to himself. He tells his disciples, why he mortified his body for six years ;—what was the cause thereof in his former lives. His disciples ask him several things, whence comes such and such a blemish or misfortune in his present life—he tells them his former immoral actions, and says that they are the consequences of these. The story of DGAH-SKYONG, an ascetic, a good moralist, leaf 14.

*Leaf 20.* SHÁKYA, after his return from the *Ma-dros* lake to *Skrá-vasti* together with the 500 Arhans, is invited and entertained by SA-GA, (RI-DAGS HDSIN-GYI-MA) a lady. His instructions to her at that occasion.

*Leaf 21.* On his peregrination in *Kosala*, SHÁKYA is invited and entertained by the Brahmans and landholders of the town *Thigs-pa-chan*. The request of 500 *Yidags* (fancied beings representing the condition of a miser) made to him. His answer to them—their excuses. His reflections (in verse) on the wrong judgments of men—that “men are ashamed of those things of which they ought not to be ashamed, and vice versâ.” He takes them with him to the entertainment, and afterwards makes his benediction to his hosts for the future prosperity and happiness of those *Yidags*.

*Leaf 23.* Dispute amongst the citizens of that place, whether GAU-TAMA and his disciples are covetous or not. They are tried by an entertainment, and are found to be moderate in their wishes and temperate in their living :—afterwards, by the same person, the Brahmanists also are invited and tried ; but they are found to be the contrary of the former.

*Leaf 24.* The use of *puram* or *buram* (molasses) is permitted to his disciples. How SMRA-HDOD-KYI-SEN-GE was enlightened and became an Arhan. He is declared by SHÁKYA to be the chief of those who are enlightened by using agreeable things. *Leaf 25.*

*Leaf 25.* From *Spong-byed*, SHÁKYA goes to *Yangs-pa-chan*, (Sans. *Vaishali*) and takes up his lodgings without the city in a house on the bank of the *Ape-pond* (Tib. *Spréhu-rdsing-gi-Hgram.*) The citizens make

a law that none of them shall invite SHĀKYA privately to a dinner, but they shall treat him publicly ; since he will not remain long enough there, to be invited by them successively. NOR-CHAN, a rich citizen, having no notice of that established law, invites SHĀKYA privately. The same do also his wife, his son, and his daughter-in-law, on the three next following days—*leaf* 26 to 31. The citizens wish to punish him—how he obtains their pardon—his riches—he, and his whole family, take refuge with *Buddha*, or adopt *Buddhism*. Their former religious and moral merits; *leaf* 32. The story of ME'-TOG-P'HRENG-BGYUD-MK'HAN, at *Varānasi*, applied to NOR-CHAN and his family.

*Leaf* 35. On the occasion of a famine, the priests of SHĀKYA are permitted to cook for themselves :—difficulties about where to cook. The ten places in which they may not prepare their victuals. What the physician prescribes to a sick priest. How permission is obtained from SHĀKYA, and how he makes use of the medicament—*leaf* 36-37. How a proper place is chosen and rendered fit for cooking for a priest.

*Leaf* 37-38. SHĀKYA at *Yāngs-pa-chan*. The use of flesh, with what restriction it is permitted to his disciples.

*Leaf* 38. At *Shrāvasti*, in the time of a famine; the *Bauddha* priests suffering from hunger are much dejected. Several concessions granted to them by SHĀKYA.

*Leaf* 40. At *Mnyan-yod* (Sans. *Shrāvasti*) the Brahmans and the laymen complain, that the priests of SHĀKYA will not accept of several things which they are willing to offer them, to acquire moral merits for their future happiness—SHĀKYA gives them permission.

*Leaf* 40-41. The sickness of SHĀRIHI-BU—the physician's prescription—MAUGAL-GYI-BU's endeavour to procure that medicine.

*Leaf* 42 to 45. The story of LUG and BZANG-BYED—their happiness—family—their great qualities :—SHĀKYA is proceeding to visit them—the malice of the *Mu-stegs-chan*, (Sans. *Tirthika*) sect, SHĀKYA's enemies, to prevent his entrance :—by what means he enters into that place.

*Leaf 48.* How a priest may give his benediction to any quantity of physic for seven days, to be used by such persons as are pure of life. Several concessions from SHĀKYA to sick persons, in their diet.

*Leaf 50.* Several anecdotes that happened at *Varānasi*, in the time of a famine, that was foretold to continue for 12 years, on account of there being no rain.

*Leaf 53.* The wonderful effects of alms-giving to a holy man or *Rishi*, or the consequences of religious and moral merits in former lives. SHĀKYA is in a place called *Uduma*. His lectures to the (fabulous) four great kings, residing on the *Ri-rab* (Sans. *Sumeru*, or *Meru*.) He recommends his doctrine to the care of those four great kings or gods, and to that of *Hod-srung*, to defend it after his death. They all promise him that they will defend it, *leaf 57*. He tells his disciples the former moral merits of those four great kings or gods.

*Leaf 59-60.* SHĀKYA is presented with eight sorts of liquor or drink, by a *Rishi*, called KENAHI-BU (the son of KENA,) he tells his disciples the use and medical virtues of them. RIVO, a *tran-srong* or hermit (Sans. *Rishi*) together with his 500 pupils, becomes the disciple of SHĀKYA. The son of KENA also having entertained SHĀKYA and his disciples (with a dinner) enters into their religious order, together with his pupils. To whose care these young pupils are committed by SHĀKYA for instruction, how they are qualified in a short time, *leaf 62*.

*Leaf 64 to 71.* Eulogium on SHĀKYA's qualities by KENAHI-BU, *leaf 71*. The story of two monks, (or religious persons) father and son, formerly barbers, at *Kāshi*.

*Leaf 72.* SHĀKYA, from *Gyad-yul*, goes to *Sdig-chan*, is invited and entertained there publicly, according to the measures the citizens had taken previously in his behalf.

*Leaf 74-75.* Stories of several entertainments to SHĀKYA and his disciples. *Leaf 76.* The story of a man bitten by a snake, how he is cured. The *Bidya Mantra* also is exhibited; (it seems to consist of significant Sanscrit

words,) in three lines. Ancient fables are told and applied to present circumstances.

*Leaf 78.* Here ends the subject on medicaments, and commences that on the garments of the priests.

The story of DUM-BU, a minister (of state) and his king HPHAGS-SKYES-PO, in *Lus-Hp'hags*; (Sans. *Vidèha*.) DUMBU escapes to *Yangspa-chan* (*Allahabad*) and settles there. He first declines to give his advice in the assembly of the people there, but afterwards renders them great service by his prudent counsel.

*Leaf 80 to 83.* Three tribes of the *Lichabyis* at *Yangspa-chan*: marriages prohibited between different tribes. The beforementioned DUMBU is made chief tribune there, (*Sdè-Dpon*), and after his death his second son. His elder son retires to *Rájagriha* in *Magadha*, to VIMBASÁRA. This king marries, on his recommendation, the daughter of his brother at *Yangspa-chan*.

*Leaf 87.* The story of AMRA-SKYONG-MA, a celebrated harlot at *Yangspa-chan*. *Leaf 90 to 92.* VIMBASÁRA'S amours with her—a son is born, and sent afterwards to the king to *Rájagriha*—he is named GYHON-NU-HJIGS-MED (the intrepid youth.)

*Leaf 92.* VIMBASÁRA commits adultery with the wife of a chief merchant at *Rájagriha*—the circumstances thereof—a son is born and sent to him—he is called “HTSHO-BYED-GZHON-NUS-GSOS”. *Leaf 94.* The education of the two natural sons of VIMBASÁRA. They wish to learn some art or handicraft.—HJIGS-MED learns carpentry, and HTSHO-BYED studies physic. The latter after having made great progress in his art, goes to *Rdo-Hjog* (Sans. *Taxashílá*, the *Taxila* of Ptolemy ?) to learn there the opening of the cranium (*Klad-pahi thod-pa hbyed-pahi dpyad*, མཎ་པའི་ཐོད་པ་འབྲེ་པའི་དཔྱད) from a celebrated physician—his genius and great abilities—several instances of his dexterity and learning, his integrity and great experience in the art of physic. *Leaf 104.* He acquires great renown by treating several diseases successfully:—is declared, at three

different times, the prince of all the physicians, by the king of *Magadha*.  
*Leaf* 107-108. Medical science:—his meeting with SHÁKYA—his improvement in curing the diseases both of the body and of the mind.

*Leaf* 111 to 114. The disciples of SHÁKYA are permitted to wear three pieces of religious clothing of a dark red colour, for distinction's sake:—what gave occasion to that permission—instruction how to prepare those garments.

From *leaf* 114. The story of SA-GA-MA, a young girl from *Champa*, married afterwards to the son of a chief officer at *Shrāvasti* in *Kosala*. Her modest and prudent conduct:—description of modest and of impudent women; she is represented as the model of modest, prudent, wise, frugal, and in many respects accomplished women. Her mother's enigmatical instruction to her with respect to her future conduct, when about to be married.

*Leaf* 124-125. Explication of those enigmatical terms. Her father-in-law expresses himself thus: "Your mother has been wise in having given you such enigmatical instructions, but you are more wise than she in having understood and practised her enigmatical advice."

*Leaf* 126. SA-GA-MA is proclaimed the mother of RI-DAGS-HDSIN and the sister of GSAL-RGYAL, the king of *Kosala*. A *Vihar* is founded in her name;—she is delivered of thirty-two eggs, from which thirty-two young boys come forth:—their adventures—they are destroyed by the king of *Kosala*, and their heads sent in a basket to SA-GA-MA their mother.

*Leaf* 129 to 131. SHÁKYA's lessons to the king of *Kosala* on that subject, SA-GA-MA's former moral and religious merits, as also the demerits of her thirty-two sons, told and applied by SHÁKYA.

*Leaf* 133. The story of RI-DAGS-MGO, an astrologer. His ill-grounded prognostication—he becomes a disciple of SHÁKYA—is convinced of the absurdity of his astrological predictions.

*Leaf* 135. SA-GA-MA at *Shrāvasti* invites and entertains SHÁKYA with his suite. Among other offerings she presents some pieces of cotton cloth, for the monks and nuns (or male and female religious persons) to make bathing clothes of them, since she had been informed that they bathed naked.

SHÁKYA at *Yangs-pa-chan*—recommends to his disciples to be clean in their bedding and clothes, and to make a proper use of the offerings made to them by their faithful followers or hearers.

*Leaf 141.* They are ordered to keep clean mattresses (or couches to sit and lie on)—excesses in;—restrictions;—itch, leprosy—how to treat such priests as are infected by those diseases.

*Leaf 142.* What sorts of religious garments are permitted by SHÁKYA to his disciples. Some of them wish to wear such and such garments, of such and such colours: to wear turbans; others to go naked. SHÁKYA tells them the impropriety and indecency of the latter and prohibits it absolutely; and, rebuking them, adds, that such a garb, or to go naked, is the characteristic sign of a *Mu-stegs-chan* (Sans. *Tirthika*.)

*Leaf 143 to 147.* A moral tale on impudence; several prohibitions respecting the dress of the priesthood; gifts must be divided equally among the priests—exceptions—many impostures committed.

*Leaf 147 to 152.* The story of two foolish old monks—how they were deceived by a certain NYE-DGAH (Sans. *Upa-nanda*) illustrated by a moral tale characterising the idiot and the crafty or impostor, *leaf 153.* Other stories of UPÁ'NANDA'S imposture.

*Leaf 162.* The death of NYE-DGAH, (Sans. *Upa-nanda*.) His immense riches. Measures taken by the king to secure for himself part of that treasure. He renounces afterwards every pretension, hearing of SHÁKYA'S representation to him, made by KUN-DGAH-VO, (Sans. *A'nanda*.) The whole substance (thirty thousand *srang* or *tola* of gold,) was divided at first amongst the whole body of priests at *Shrávasti*, but afterwards the priests of all the six cities of Central India, (as, of *Sáketána*, *Varánasi*, *Vaishali*, *Champa*, and *Rájagriha*) having alleged their claims, were admitted all to share with them, *leaf 164.* The ceremony with which it is divided, *leaf 165.* A moral tale on covetousness, told by SHÁKYA and applied to the above described NYE-DGAH.

*Leaf 166.* How to divide the effects of deceased religious persons; several stories on the subject—intermixed with moral tales, mostly relating to *Shrávasti*.

*Leaf 185.* Here ends the subject "on the garbs or garments of the religious persons" (*Gos-kyi-Gzhi*), and follows that "on mats and spreading cloths" (*Sra-Brkyang*.)

*Leaf 186.* Several religious persons after having passed the three months of the summer at *Sáketána* (Tib. *Gnas-Bchas*), go to *Shrávasti* to pay their respects to SHÁKYA, who had summered there. They went thither much tired on account of the *jangal*, morasses, and great heat on their road, and were covered with dust. The use of *Sra-Brkyang* (any cloth or thing to spread on the ground, for sitting and lying on, or a mat) is permitted by SHÁKYA. Several ceremonies; of what, how to prepare, and how to use them, *leaf 200*.

From *leaf 200 to 219*. *Kaushámbhi* (a city); (SHÁKYA in the *Dvyangsdan-gyi-kun-dgah-rá-va*, or Sans. *Ghos'havatyávráma*); several priests at *Yangs-pa-chan*, well read or versed in the *Hdul-va*, *Mdo*, and *Ma-mo*, go to *Kaushámbhi* and dispute with the priests of that place, who were likewise well versed in those scriptures; thence many disputes and quarrels upon various points, for twelve years;—they are rejected by the citizens, on account of their conduct. They will no longer give them alms. They repair to SHÁKYA at *Shrávasti*, are ill received by him, and not admitted till they have repented, confessed their faults, and have begged pardon for them.

*Leaf 219 to 229*, Stories of the misconduct of some religious persons; discussions on what is lawful and unlawful, (or against religious discipline,) in the common practices of the priests.

*Leaf 229 to 272*. Stories of several priests, that had violated the established rules of discipline—the proceedings of the priesthood against them; several priests of the *Dmar-ser-chan* band at *Shrávasti*—the cause of many quarrels and disputes among the priests. SHÁKYA's orders, how such persons are to be admonished of their misbehaviour, and treated by the community. *Leaf 235 to 239*. LEGS-LDAN, a priest, on account of his several faults, is rebuked solemnly in the congregation—begs pardon, and obtains it—the circumstances thereof. *Leaf 239*. The faults of two other priests (*HGRO-MGYOGS*, and *NAP-SO*) are enumerated: they are



rejected from the community;—under what conditions may such again be received. The story of *HCH'HAR-KA* a dissolute priest.

*Leaf 272 to 291.* The *Gang-zag-gi-Gzhi* or “on the inward man.” The recollection of any committed fault or sin, the confession of it to any priest. Alteration or self-emendation—time granted for one’s repentance by the congregation of the priests. The rites and ceremonies of obtaining pardon for one’s smaller sins or faults. Several instances of committed, and afterwards confessed, sins or faults.

*Leaf 291 to 298.* The *Spo-vali-Gzhi* “on the changing of one’s self,” after committing sins or faults, and on repentance; how to ask the priests’ forgiveness.

*Leaf 298 to 306.* The *Gso-sbyong-Gzhag-pa* the putting aside or leaving off the feast of the confession. (There are several passages descriptive of the general degeneration and corruption of the priests.)

*Leaf 306 to 365.* The *Gnas-mal-gyi-Gzhi* on lodging and bedding (or dwelling place, utensils, furniture, &c.) The circumstances of several establishments (called in Tib. *Gtsug-lag-k'hang*, Sans. *Vihar* or *Bihar*) being made for SHÁKYA and his disciples, especially a large one at *Shrávasti*, in *Kosala*, by a rich landholder. Many rules and instructions respecting religious discipline.

*Leaf 365 to 418.* The *Rtsod-pahi-Gzhi*, on disputes and quarrels of the monks—several instances thereof, with their circumstances.

*Leaf 418 to 478.* To the end of the volume is the *Dgè-hdun-Dvye-pahi-Gzhi*, “the causing of divisions among the priests,” (as the general subject is stated on the 418th leaf; but there is nothing to be found of that kind.)

*Leaf 418-419.* Is a specification of the names of the persons whose histories are about to be mentioned. Names of several (fabulous) universal monarchs (*Chakravartti*) in ancient India..

From leaf 419 to 446. The (fabulous) history of the SHÁKYA race, told by MAUGALYANA. The circumstances thereof (SHÁKYA being at a certain

time in the *Nyagrodha Vihar*, near *Capilavastu*, the inhabitants of the *Shaka* race, desirous to know the origin and history of their nation, go in great number to him, and request of him to acquaint them with the history of their origin, that they may satisfy others on the subject. SHÁKYA directs MAUGALYANA, one of his principal disciples, to tell them their origin, in an instructive manner, and he himself lies down to sleep during the narration.) MAUGALYANA addresses the inhabitants thus: "Descendants of GAUTAMA! (Tib. *Gohutama-tag*)," and commences his narration by telling them, how the world was renewed after its former destruction. How the animal beings were successively propagated. The origin and causes of the different kinds, sexes, colours, qualities—their degeneration. The origin of property, laws, magistrates, universal monarchy, their descendants till the time of SENGEHI-HGRAM, the grand father of SHÁKYA. Here ends the narration of MAUGALYANA. SHÁKYA much approves it, and recommends to the hearers to keep it in their memory. The rest of the volume, from leaf 446 to 478 contains the circumstances of the birth and education of SHÁKYA. His bodily and intellectual accomplishments:—his several acts or performances; his marriages; his leaving his father's house to live an ascetic life. Here ends the 3d volume of the *Dulvá*.

THE 4TH (OR 5<sup>th</sup>) VOLUME OF THE *Dulvá*,  
 Containing 470 leaves, 27 parts or books, from the 83d to the 109th book,  
 inclusive.

*Subjects* :—From leaf 1 to 22. The continuation of the circumstances that determined SHÁKYA to take the religious character. His reflections on old age, sickness, death and religious state. His seeing the wretched condition of the agriculturists, or labouring class. A miracle with the shadow of a tree (the *jambu* tree). His marriages with SA-ETS'HO-MA, GRAGS-HDSIN-MA, and RI-DAGS-SKYES. The circumstances thereof. His

earnest desire to take the religious character. The precautions which his father takes to prevent him from leaving the court—his wife's and other dreams. His being exhorted (in verse) by INDRA, BRAHMÁ, and by other gods, to renounce the world: his replies—his exit or departure—the circumstances thereof. His discourse with his groom (HDUN-PA)—his fine horse (*Rta-mch'hog-Bsnags-ldan*), leaf 22.

*Leaf 23.* He commences his ascetic life. *Leaf 24.* He arrives at *Rájagriha*, the king (VIMBASÁRA) observes his conduct, is much pleased with it: sends some of his men to see who and what sort of man he is—they make their report. Afterwards the king himself with his officers pays a visit to him:—their conversation (in verse). SHÁKYA tells him, that “there is in the neighbourhood of the *Himálaya* (or *Kailásha*, Tib. *Gangs-ri*) a country called *Kosala*, full of riches and grain or corn, inhabited by the SHÁKYAS, the descendants from PURÁM SHING-PA (Sans. IKSHWAKU, of the *Surya vansha* or *Angirása*): that he is of the royal tribe, and that he has renounced all worldly desires, leaf 25.

*Leaf 26.* He quits *Rájagriha*, goes to the *Griddhrakuta* hill, and successively visits several hermits of different principles: is easily admitted by each, but seeing the absurdity of their tenets and practices, he leaves them soon: he out-does them all in their mortifying practices, hence he is styled *Dge-sbyong-ch'hen-po*, the great priest (Sans. *Mahá Sramana*.)

*Leaf 29.* The manner in which he gives himself to meditation, and performs his mortifications, on the banks of the *Nairanyjana* river, leaf 38-39. He finds great delight in meditation, but, perceiving privation to be hurtful to his mental faculties, he resolves to make use of nourishing foods:—he is presented with a refined milk-soup by two maids. He is deserted by his five attendants on account of his new mode of living.

*Leaf 43.* He proceeds to *Rdo-rjé-Gdan* (Sans. *Vajrásan* near the modern *Gáya*), gives himself to meditation, overcomes the devil, and finds the supreme wisdom—becomes a saint or Buddha; great joy in his father's court upon hearing of his exalted state; why such names were given to

RAHULA and A'NANDA, his son and cousin, at *Capilavástu*, who were born on the same night he became a saint, *leaf 51-52*.

*Leaf 59.* On the exhortation of BRAHMÁ, the god of the universe, he resolves to communicate his doctrine to others also, according to their capacities. He goes to *Varánasi*. Those five attendants, that had left him lately, on account of his welfaring, being convinced of his perfections, first of all become his disciples. Afterwards the number of his followers rapidly increases. All sort of ascetics ; men of different tribes and professions go over to him and adopt the Buddhistic doctrine. There are in this volume several detailed accounts how such and such persons, at such and such places, have adopted his doctrine. Instructions. Compliments. The four truths.

*Leaf 106.* The birth place of SHÁKYA near the *Himálaya*, on the bank of the *Bhagirathí* (Tib. *Skal-ldan-shing-rta*), not far from *Capilavástu*, (Tib. *Ser-skya-Gzhi*.)

*Leaf 107-8.* The king of *Magadha*, VIMBASÁRA SHRENIKA, offers to SHÁKYA and his priests a support in all necessary things, as long as he shall live.

*Leaf 109.* The five insignia of royalty (of VIMBASÁRA)—1. An ornamented pillow or throne. 2. An umbrella or parasol. 3. A sword. 4. A chowrie of cow-tail, the handle beset with jewels. 5. Particoloured shoes.

*Leaf 123.* Terms for rousing or calling on the domestics, and giving them orders for making ready breakfast.

*Leaf 128.* The history of a religious establishment of several large buildings (Tib. *Gtsug-lag-k'hang*, Sans. *Vihar* or *Bihar*) in a grove near *Shrávasti*, in *Kosala*, by a rich landholder. *Leaf 137.* SHÁKYA is invited thither—his journey—miracles that happened there at his arrival.

*Leaf 142.* The king of *Kosala*, GSAL-RGYAL, in a letter informs the king, ZAS-GTSANG-MA (Sans. SUDHODANA) the father of SHÁKYA, that his son has found the food of immortality, with which he is recreating all men. His father, desirous to see him, sends several messengers to invite

him; they all enter into his religious order—not one returns even to give intelligence. At last, CHAR-KA, his minister, begs leave to go himself, and bring intelligence to him. He promises that, in every case, he will certainly come back. With a letter from the king he repairs to SHÁKYA at *Shrāvastī*. He too becomes a convert to Buddhism, but he is permitted to go back, as a priest, to inform the king of these events, and to predict that in seven days he should see his son at *Capilavástu*. SHÁKYA'S instructions to CHAR-KA how he should behave himself at *Capilavástu*, and answer the king's inquiries, *leaf 144. Leaf 144.* Comparison of great and small things. Preparations for the reception of SHÁKYA.

*Leaf 146.* Orders from the king to his officers, to build in the *Nyagrodha* grove, sixteen large and sixty smaller rooms. SHÁKYA, with several of his disciples, goes to meet his father at *Capilavástu*.

*Leaf 149.* Description of their meeting—their mutual compliments and conversation (in verse), *leaf 150 to 152.* Religious instruction:—the *Shákya* race adopts his religion, and from every family or house one person takes the religious character. The stories of several individuals of the family of SHÁKYA. *Leaf 164,* NYE-VÁR-HK'HOR, a barber of the *Shákyas*, enters into that religious order—acquires great perfection—he is the pretended compiler of the *Dulvá* class.

*Leaf 171.* The history of KOHUDINYA, one of the principal disciples of SHÁKYA, as also that of others.

*Leaf 242-3.* KUN-DGAH-VO (Sans. A'NANDA) is made the chief disciple of SHÁKYA.

*Leaf 341.* LUS-HP'HAGS-MAHI-BU MA-SKYES-DGRA causes his father's (VIMBASÁRA'S) death. By whom he is comforted in his great troubles or anxieties.

*Leaf 349.* LHAS-SBYIN or LHAS-BYIN, one of SHÁKYA'S cousins—his great hatred and malice towards SHÁKYA. Several instances quoted, and many moral tales told by SHÁKYA, and applied to himself and to this

LHAS-SBYIN,—or to any other individual : for under the name of LHAS-SBYIN (Sans. DEVADATTA), is frequently understood any malicious character, or wicked man.

*Leaf 392.* The circumstances of LHAS-SBYIN'S proceedings to cause divisions among the disciples of SHÁKYA. Several stories are told and applied to LHAS-SBYIN and to MA-SKYES-DGRA, the king of *Magadha*, to show the ill consequences of bad morals.

*Leaf 417 to 449.* SHÁKYA'S moral instructions to the king of *Magadha*, MA-SKYES-DGRA ; (many of them nearly in the same words as above, in the 2nd volume of the *Dulvá*, to MA-SDUG.)

*Leaf 449.* LHAS-SBYIN'S further plots for injuring GAUTAMA (SHÁKYA). Several stories and instructions.

*Leaf 470.* Here ends the subject of “causing divisions amongst the priests;” which terminates also the general subject of “religious discipline” Tib. *Stdul-va-Gzhi*, Sans. *Vinaya Vástu*.

These four volumes of the *Dulvá* collection were translated from the Indian or Sanscrit language in the 9th century of our era, by SARVAJNYÁ-DEVA, VIDYA KARA PRABHA, and DHARMAKARA, learned Pandits; the first and the third from Cashmir, the second from India; and by the Tib. *Lotsáva*, *Bandè DPAL-GYI-LHUN-PO*. They were afterwards corrected and set in order by the Indian Pandit VIDYAKARA PRABHA, and the Tib. *Lotsáva*, *Bandè DPAL-BRTSE'GS*.

In the next four volumes of the *Dulva* class, (from the 5th to the 8th inclusive, marked by the letters ३, ४, ५, ६) is an enumeration of the several laws or rules, (*Khrims*) 253 in number, respecting the conduct of the priests (*Dge-slong*), and an explanation of those rules, in several detailed stories or parables.

In the beginning of the 5th (or ३ *Cha*) volume, from *leaf* 1 to ३0, is the treatise on emancipation. (Sans. *Pratimoksha Sūtra*, Tib. *So-sor-thar-pahi-M,do*.)

*Contents of the Treatise on Emancipation.*

Adoration of the All-knowing, or salutation to *Buddha*—Praise and importance of this *Sûtra*.—The several blessings arising from the practice of good morals.—Celebration of the confession (*Gso-sbyong*), on every new and full moon.—Rehearsal of the established rules or precepts, pronounced by the chief (or other officiating) priests.—Exhortation to the priests to examine themselves and to confess their sins with a loud voice, if they have any.—The compendium or sum of the *Buddhistic* doctrine in one *slòka* thus, in Tibetan:

ཨོ རྗེ་ཡ་ཅི་ཡང་མི་བྱ་ཤིག །	“ No vice is to be committed,
དགེ་བ་རྣམ་པར་སྤྲོད་པ་ཡི་ཡིག །	Virtue must perfectly be practised,—
རང་གི་སེམས་ཅི་ཡོད་པ་ལྷུ་གུ་ལ།	Subdue entirely your thoughts.
འདི་ནི་སངས་རྒྱལ་གྱི་ཡོན་ཏན་ལོ།	This is the doctrine of <i>Buddha</i> .”

On leaf 30th. Commendation of the *Bauddha* faith, in the following two *Slòkas*: in Tibetan: (vol. 5, leaf 30.)

1. ཨོ། བརྩམ་པར་བྱ་བའི་འཇིགས་པར་ལྷོ། ། སངས་རྒྱལ་གྱི་ཡོན་ཏན་ལོ། །
- འདས་ལྷོ་ལྷོ་ལྷོ་ལྷོ་ལྷོ་ལྷོ་ལྷོ། ། འཇིགས་པར་བྱ་བའི་ཡོན་ཏན་ལོ། །
- གང་གིས་རྩལ་ལྷོ་ལྷོ་ལྷོ་ལྷོ་ལྷོ། ། འཇིགས་པར་བྱ་བའི་ཡོན་ཏན་ལོ། །
- ལྷོ་ལྷོ་ལྷོ་ལྷོ་ལྷོ་ལྷོ་ལྷོ། ། ལྷོ་ལྷོ་ལྷོ་ལྷོ་ལྷོ་ལྷོ། །

In English:

“ Arise, commence a new course of life—turn to the religion of *Buddha*. Conquer the host of the lord of death (the passions), that are like an elephant in this mud-house (the body), (or conquer your passions like as an elephant subdues every thing under his feet, in a muddy lake); whoever has lived a pure or chaste life, according to the precepts of this *Dulva*, shall be free from transmigration, and shall put an end to all his miseries.”

An assertion follows that the *Pratimohsha Sûtra* has been recommended by each of the seven last *Buddhas*, who are styled here the seven *Bauddha* champions (Tib. *Dpah-vo*, Sans. *Vira*, Eng. Champion or Hero.) The names of those seven *Buddhas*, on the 30th leaf, are thus given in Tibetan: 1. *Rnam-par-Gzigs*, 2. *Gtsug-tor-chan*. 3. *T'hams-chad-skyob*. 4. *Hk'hor-va-Hjig*. 5. *Gser-t'hub*. 6. *Hod-srung*. 7. *Shákya-t'hub-pa*.

They correspond to the Sanscrit: 1. *Vipashyi*. 2. *Sik'hi*. 3. *Vishwábhu*. 4. *Kakutsanda*. 5. *Kanaka-muni*. 6. *Káshyapa*. 7. *Shákya Muni*.

From the 30th leaf of the 5th (or 3 *Cha*) volume to the end of the 8th (or 9, *Nya*) volume, is contained the "explanation of the religious discipline," (Sans. *Vináya vibhanga*, (better *Vibhága*,) Tib. *Hdul-va-rnam-par-Hbyed-pa*.)

In these four volumes, are several stories of immoral actions, committed by some one of the religious persons belonging to the disciples of SHÁKYA. The crime, generally, becomes divulged amongst the people, who blame the conduct of the priests. SHÁKYA is informed afterwards of the fact. The delinquent is cited before the congregation; confesses his fault; and is rebuked by SHÁKYA: who then explains the immorality of the act, makes a law thereupon, and declares that whoever shall violate it, shall be treated as a transgressor.

The stories, in general, are of little importance, and many of them too indecent to be introduced here.

The two hundred and fifty-three rules to be strictly observed by the priests (*Dgè-slong*) are of five kinds, (or there are five kinds of sins or faults provided against in those rules.)

1. There are some for the violation of which they are expelled from the order. Such are the laws or rules against adultery or, in general, fornication; robbery or stealing; murder or destruction of animal life; and the giving out (or selling) of human doctrine as a divine revelation.

2. By the violation of a second class of rules, they become outcasts from the priesthood, or are degraded. Such crimes are—the emissio seminis; indecent behaviour; immodest talk; the causing of divisions amongst the priests; the blaming of the secular state, &c. &c.

3. In the 3rd class are reckoned thirty faults;—as the keeping or wearing of more clothes than is permitted—neglecting to wear religious garments—the deposition of them at any place, &c.—prohibited materials for clothes, &c.



4. In the 4th class are enumerated ninety faults.

5. The 5th kind of faults or sins are such as must be confessed. Besides these rules, are numerous instructions regarding decent behaviour, dress—attitude or posture of the body—manner of eating and drinking, and when giving religious instruction to others.

On *leaf* 30 to 32. Praise of religious discipline in general, (in verse.)

From *leaf* 33 to 74. Several stories on fornication or adultery. *BZANG-BYIN*, a priest, commits adultery. *SHĀKYA* is informed of the fact. He is cited—rebuked—and expelled. A rule is made that thenceforth all adulterers shall be expelled. The circumstances of this story may be seen, *leaf* 33 to 40, together with the terms *SHĀKYA* used in rebuking the guilty.

From *leaf* 74. On stealing or robbery.

Anecdotes—kinds and modifications of theft—several instances of cheating, tricks and frauds in eluding the duties at custom-houses, &c.

*Leaf* 105. There are likewise several instances, how traders have defrauded the custom-houses, in putting some of their precious things into the bags of the monks.

*Leaf* 155 to 166. The consequences of lust and theft—fabulous history of the origin of evil in the world.

From *leaf* 162 to 239. Several stories of suicide and poisoning amongst the monks, or of causing themselves to be slain or deprived of life, out of grief or despair, upon hearing of the various kinds of miseries or calamities of life. *SHĀKYA* prohibits discoursing on the miseries of life, so as to bring others to desperation thereby.\*

*Leaf* 270 to 274. Pretended supernatural knowledge attributed to the communication or inspiration of any divinity. Terms for rebuking such pretenders.

---

\* For a similar story, see Ainsworth's Dictionary under *Hegesias* in the *Index Nom. prop.*

"HEGESIAS, a philosopher of Cyrene, who displayed the miseries of life with such eloquence, that several slew themselves to be out of them; for which reason he was commended by Ptolemy to discourse no more on that subject."

*Leaf 306.* Several women of respectable families, at *Shrāvasti*, visit the *Vihars* (colleges and halls) in a garden near that city, conducted by CH'HAR-KA a priest, who tells them whose *Vihars* and halls they are, with some biographical notices. His immodest behaviour. The stories of several immoral actions, by which a priest loses his character or rank, and becomes an outcast from the priesthood. On making dissensions amongst the priests.

There are thus in this volume 439 leaves, the 30 first of which are occupied by the Treatise on Emancipation, in two books, 700 *Ślōkas*. The rest of the volume contains the first books of the "Explanation of Religious Discipline."

THE 6TH (OR ३ *Ch'ha*) VOLUME,  
Containing twenty-one books, or 431 leaves.

Continuation of the subject (begun towards the end of the 5th volume) on causing divisions amongst the priests. LHAS-BYIN's endeavours to seduce the disciples of SHĀKYA to his party.

*Leaf 34.* SHĀKYA visits *Kaushambhi*, and takes his lodgings in the *Gdangs-chan-gyi-kun-Dgah-ra-va* (Sans. *Ghos'havatyārāma*):—stories of discontentment. The disciples of SHĀKYA, on account of their being of different tribes, families, houses, &c., are likened to an assemblage of all sorts of leaves fallen from the trees, in autumn, and brought together by the wind.

*Leaf 57 to 61.* The priests of SHĀKYA are said to have so many clothes that for each business they make use of a different suit; and that, through dressing and undressing themselves, they have little leisure to read and study. They are prohibited from keeping superfluous garments or clothes. Several rules concerning superfluous clothes and other utensils of the priests. As also, rules concerning the wearing, and omitting religious garments, and depositing them or utensils at any place.  
*Leaf 61 to 93.*

*Leaf* 93 to 143. Rules concerning the washing of clothes. Several stories told of the uncleanness of the priests. The birth of SHÁKYA. Correspondence between GSAL-RGYAL, the king of *Kosala*, and ZAS-G'TSANG the father of SHÁKYA. *Leaf* 102. A letter from ZAS-G'TSANG to SHÁKYA—his life—he is invited—he visits his father. Dialogue (in verse) between them. *Leaf* 110-111. Description how the *Shákya* race adopted *Buddhism*. *Leaf* 131. Expressions of enthusiasm, devotion and joy uttered by five hundred of the relations of SHÁKYA, upon their being instructed in his doctrine.

From *Leaf* 325 to 431, or the end of the volume, are several stories on hoarding or laying up stores,—on lying and falsehood,—and on ridiculing or despising others.

THE 7TH (OR ॠ *Ja*) VOLUME OF THE *Dulva* CLASS.

*Containing twenty books, (from the 43d to the 63d) and 446 leaves.*

In this volume is the continuation of the stories of several faults or slight crimes committed by the priests. Such faults are reckoned ninety in number. The same are introduced into the Sanscrit and Tibetan dictionaries; but, since they are of little importance, it is unnecessary to specify them in this place. The Sanscrit generical name for this class of faults, is *Shuddha práyash chittakah*. Tib. *Ltung-byed-Hbah-zhig*, English: "what are mere faults, or venial faults". The volume commences with stories on abuse or foul language (*Hp'hyá-va*.) and ends with narratives regarding culpable priests, that had been ordained (or made *Gélongs*) before they had reached the age of twenty.

THE 8TH (OR ॡ *Nya*.) VOLUME OF THE *Dulva* CLASS.

*Containing 21 books, (from the 63rd to the 83rd inclusive,) and 417 leaves.*

This volume is filled with the continuation of stories on faults or slight crimes of the same kind with those in the preceding volume. It

commences with the narration of a fault committed by digging the ground, and ends with anecdotes on the adjustment and quelling of quarrels and disputes.

THE 9TH (OR 7 *Ta*) VOLUME OF THE *Dulva* CLASS, in 483 leaves.

This volume regards the nuns or female religious persons of the *Bauddha* faith. The subjects are the same as those of the last four volumes, for the priests. And the stories are told in the same terms, with the exception of some additions and applications.

From *leaf* 1 to 36, in 2 books, is the treatise on emancipation, for the priestesses (*Gelongma*), Sans. *Bhikshuni pratimoksha Sutra*, Tib. *Dge-slong-mahi-so-sor-t'har-pahi-Mdo*. (See the beginning of the 5th volume).

From *leaf* 36 to 483 or to the end of the volume, in 28 books, is the "Explanation of the religious discipline of the priestesses," Sans. *Bhikshuni Vinaya vibhanga*, (or *Vibhāga*) Tib. *Dge-slong-mahi-hdul-va-rnam-par-hbyed-pa*; in the same manner, order, and in the same words, as in the former four volumes; with the exception of some stories, and a few instances not mentioned there.

*Leaf* 61. MA-SKYES-DGRA, (SANS. AJĀTASHATRU) the king of *Magadha*. How and by whom he is comforted after he had caused the death of his father VIMBASĀRA.

*Leaf* 78 to 87. Stories of several religious persons having put an end to their lives, out of despair. *Leaf* 85. Several kinds of robbers.

*Leaf* 108 to 109. SBOM-DGAH-MO, a priestess or nun, the pattern of a lewd, cunning and wicked woman. There are several stories under her name, in this volume.

*Leaf* 193. LHAS-BYIN, one of SHĀKYA's cousins, the model of a malignant and rancorous person. How he endeavours to acquire the knowledge of the magical art, or of performing prodigies. He applies to SHĀKYA—and, upon his refusal, to his principal disciples. They all refuse to instruct him. He is advised by each of them first to acquire true and useful

knowledge. He endeavours to excite dissensions, and to make divisions among the priests—as also among the priestesses, through *SBOM-DGAH-MO*.

*Leaf 216.* Stories on the multiplicity of clothes and garments of the female religious persons. Prohibitions against them by *SHÁKYA*.

*Leaf 272.* The king of *Kalinga* sends to *G̃SAL-RGYAL*, the king of *Kosala*, a piece of fine linen cloth, as a present. It comes afterwards into the hands of *G̃TSUG-DGAH-MO*, (a lewd or wicked priestess) she puts it on, appears in public, but, from its thin texture, seems to be naked. The priestesses are prohibited from accepting or wearing such thin clothes.

*Leaf 282.* Mention is made of the four *Vedas* of the Brahmans. *Leaf 284-5.* Several terms peculiar to the loom, and to other mechanical arts, are enumerated. Defects in the body of a nun. Censure of others.

*Leaf 286.* Moral tales on secret slander.

*Leaf 302.* Several parts of the *Dulvá* class enumerated.

*Leaf 331.* *Kun-tu-rgyu*, “going every where,” (Sans. *Parivrājaka*) is said to be the same with *Grangs-chan*, (Sans. *Sínk’hya*).

*Leaf 362.* Names of several diseases. The rest of the volume is occupied with stories respecting the conduct of the nuns. Several rules to be learnt and observed. The scene of all these stories is, in general, *Mnyan-yod*, (Sans. *Shrāvasti* in *Kosala*).

The five last volumes (marked with the letters ཨ, ས, ས, ཨ, and ཨ of the Tib. alphabet) were translated from Sanscrit into Tibetan, first, (in the 9th century) by *JINAMITRA*, a pandit of *Cashmir*, of the *Vaibhashika* philosophical sect, and by *KLUHI-RGYAL-MTS’HAN*, a Tibetan *Lotsáva*, or interpreter. Other translators also are mentioned.

TENTH AND ELEVENTH ( ཨ *T’ha*, AND ཨ *Da*) VOLUMES OF THE *Dulvá*,

In 60 books, of which the 10th volume contains 17, or 324 leaves—and the 11th, 33 books, or 708 leaves.

These volumes are entitled in

Tibetan :—*Hdul-va-p’hran-ts’hegs-kyi-Gzhi*. Sanscrit :—*Vináyā Kshu-draka Vastu*.

English :—“Miscellaneous minutiae on religious discipline.”

The 10th volume, after the title of these two volumes has been expressed, commences by—"reverence to the All-knowing." The subject is then set forth in three stanzas, as—things relating to the discipline and conduct of the religious persons of the *Buddhist* sect, and the manners and customs of the people of Central India, the scene of the several acts described in the *Dulva*.

*Leaf 2.* SANGS-RGYAS-BCHOM-LDAN-HDAS (SHĀKYA,) at *Yangs-pa-chan* (Sans. *Vaishali*, or *Vishali*, *Pryāga* of the ancients, the modern *Allahabad*). That city is inhabited by the *Lichabyi* race. Descriptions of its gardens or orchards, music, gymnastic exercises, baths. The disciples of SHĀKYA incur scandal there by rubbing themselves with tiles or bricks with too great a noise. They are prohibited by SHĀKYA from rubbing themselves with tiles, except their feet.

*Leaf 5.* SHĀKYA at *Mnyan-yod* (Sans. *Shrāvasti*). Forbidden to rub themselves with fish-gills, instead of tiles or bricks;—to anoint themselves with fragrant substances, except when prescribed by the physician. What to do with the fragrant substances that are offered them by their pious followers.

*Leaf 7.* Mention is made of some fanes or chapels, (Sans. *Chaitya*, Tib. *Mch'hod-rten*) where the hair or nails of *Buddha* are deposited, and revered as sacred things.

*Leaf 11.* Seals are permitted to the priests—excesses in regard to seal-rings (Tib. *Sor-Gdub-rgya*). They are forbidden to have them of gold, silver, or precious stones. They are prohibited from wearing rings. But they may keep seals or stamps made of copper, brass, bell-metal, ivory, horn—excesses in regard to the figures cut on them.

*Leaf 12.* A man of the religious order must have on his seal or stamp, a circle with two deer on opposite sides, and below them the name of the founder of the *Vihara* (Tib. *Gtsug-lag-khang*). A layman may have either a full length human figure or a head cut on his signet.

*Leaf 25.* Predictions by SHĀKYA and by a gymnosophist, of a child that was to be born. Its miraculous birth. It is named "fire-born" (*Me-skyés*). His education and adventures.

*Leaf 28.* The veracity of a *Buddha* is expressed thus :—“the moon, together with the hosts of stars, may fall down ; the earth, together with the mountains and forests, may lift itself up into the void space above ; the vast ocean may be dried up ; but it is impossible that the great hermit (*Mahá Sramaña*) should tell a falsehood.”

*Leaf 58 to 61.* Several false charges or calumnies at *Yangs-pa-chan*, especially that of *Lichabyi-ck'hen-po*. The priests of SHÁKYA were wont to put under ban or interdiction any person, or family, according to the following ceremony :—In their congregation, after having been informed of the facts, they turned an alms-dish or goblet, with the mouth downwards ; declaring by that act, that thenceforth none should have communication with him or his house, (according to the text, no one should enter his house, neither sit down there, nor take alms from him, nor give him religious instruction.) After reconciliation had been made, the ban was taken off, by replacing the alms-dish.

*Leaf 64 to 66.* SHÁKYA prohibits his disciples from learning music, dancing and singing, or visiting places where they are exhibited. Several stories are told of the practices of the religious persons.

*Leaf 105.* The use of garlick is interdicted to the priests, except when prescribed as a medicine—how to be used there.

*Leaf 111.* Permission to keep umbrellas. Excesses regarding, by using too costly stuffs,—adding too many trimmings,—or adorning the handles of them with gems, pearls, and precious metals.

*Leaf 141 to 144.* The king of *Kosala*, *Gsal-rgyal*, being dethroned by his son, *Hp'hags-skyes-po*, goes to *Rájagriha*, to *Ma-skyes-dgra*, king of *Magadha*,—alights in a grove or garden near that city, belonging to the king, and sends him intelligence of his arrival. The king of *Magadha* orders preparations for receiving him solemnly. But in the mean time he dies in the garden, suddenly, from indigestion, caused by an immoderate use of turnips and fresh water. His funeral. SHÁKYA's instruction to the king of *Magadha*.

*Leaf 145 to 160.* HP'HAGS-SKYES-PO, the king of *Kosala*, at the instigation of MALA QNOD, makes frequent attacks on the *Shákya* race at *Ser-skya* (Sans. *Capila*) at last he takes their city and massacres many of them. Those that escaped, dispersed themselves in the hills; many of them are said to have gone to *Nepál*. During that war, a certain *Shákya*, SHÁMPAKA is banished from *Capila*. At his parting request, SHÁKYA grants him, in an illusory manner, some hairs of his head, some nail-parings, and teeth. He goes to a country called *Bagud* or *Vagud*, is made king there, and builds a fane or chapel (San. *Chaitya*, Tib. *Mch'hod-rten*) for those holy relics, called afterwards the fane or chapel of SHÁMPAKA, *leaf 149-150*.

*Leaf 160.* The death of HP'HAGS-SKYES-PO, caused by a conflagration. Relation of the circumstances that preceded it.

*Leaf 182-183.* GAUTAMI' (SKYE'-DGUIH-BDAGMO-CH'HEN-MO) and 500 other nuns die. Earthquake and other miracles that accompanied that event. A moral tale upon their former religious merits told by SHÁKYA, *leaf 185*.

*Leaf 202 to 248.* SHÁKYA gives to DGAH-VO (Sans. NANDA) instructions and lessons on several subjects, especially on the state of existence in the womb, and the gradual formation of the human body.

*Leaf 273.* Instruction how to build and cover a fine house. After which to the end, or to *leaf 324*, there are many short stories, respecting the conduct, dress, victuals, &c. of the religious persons.

#### ELEVENTH (OR ५ *Da*) VOLUME OF THE *Dulva*,

*In 708 leaves and 33 books, counting from the 18th to the 60th inclusive.*

*Subject:—*The title of this and of the preceding volume (miscellaneous minutiae on religious discipline) evinces the nature of the materials to be found here. They are of little consequence, except a few allusions to events, persons, customs, manners, places or countries. These volumes are mostly filled up with religious instructions, rules for the conduct



of the priests, and their several transgressions. NYE'-VÁR-ER'HOR (Sans. UPÁLI), the supposed compiler of the *Dulva* collection puts questions to SHÁKYA how he is to act in such and such cases and receives his instructions thereon.

*Leaf 1-2.* DGAH-VO (Sans. NANDA), a priest with SHÁKYA at *Mnyan-yod* (Sans. *Shrāvasti*), receives from his former wife, BZANG-MO, from *Ser-skya* (Sans. *Capila*) several finely bleached clothes calendered or glazed with ivory.

*Leaf 53.* When wood is not procurable to burn a dead body, neither is there any river to throw the corpse into, it may be buried.

*Leaf 61.* The death of SHÁRIHI-BU. SHÁKYA'S reflections on him. A *Mch'hod-rten* (Sans. *Chaitya*) is built over his remains by a rich landholder at *Shrāvasti*, and an anniversary festival established in his memory. The king of *Kosala* orders that, at the celebration of those festivals, merchants, who come from other countries, shall pay no duties or taxes, *leaf 68.*

*Leaf 126-127.* KATYÁHI-BU (Sans. KÁTYÁYANA) becomes the disciple of SHÁKYA, who tells him how other philosophers are in two extremes, and that he (SHÁKYA) keeps a middle way. He acquaints him with some of his principles, especially with the four great truths, and the twelve casual concatenations.

*Leaf 130.* KÁTYÁYANA, with 500 other priests, is sent by SHÁKYA to convert to his doctrine the king of *Hp'hags-rgyal\** (GTUM-PO-RAB-SNANG)† together with his consorts, son, and officers. He passes on his way through *Kanya-kubja*, a place where he had an acquaintance, a Brahman, who was dead at that time. The story of that Brahman's daughter, with the beautiful hair. His arrival, how he was received by the king. His successes there. How the king afterwards married the damsel. Anecdotes regarding. *Leaf 194.* He erects *Vihars* and makes several donations to the companions of KÁTYÁYANA. *Leaf 197 to 207.* Many witty sayings (in verse). *Leaf 207 to 209.* The ten powers of Bauddha.

\* Sans. *Ujjayani* or *Oujein*, in *Málava*.

† Sans. *Rájá Pradyota*; (called the passionate or cruel.)

*Leaf 227* Various defects of the human body are enumerated in verse. Such as have them, prohibited from being received into the religious order of SHÁKYA.

*Leaf 230 to 253.* Account of the great prodigies exhibited by SHÁKYA, at *Shravasti* in *Kosala*. The six *Mu-steps-chan* (Sans. *Tirthika*) teachers, being discontented with the treatment they meet with from the king, the officers, the brahmans, and the people in general, (who all show much favour to GAUTAMA and his followers,) so that they can hardly gain their livelihood, endeavour to vie with GAUTAMA in exhibiting prodigies, to show their skill and power. They are defeated :—for shame some of them put an end to their existence, others retire to the hills on the north of India. *Leaf 248*, the great astonishment of all at the miracles of GAUTAMA,—their applause.

*Leaf 253 to 307.* The story of BSKYED-PA a king in *Lus-hp'hags* and other tales ( Sans. *Vidéha*) told by SHÁKYA,—political intrigues. The farther history of the before mentioned six teachers.

*Leaf 276.* The story of SMAN-CH'HEN, the son of GANG-PO in a town of *Purna kachha* a hilly country. *Leaf 321 to 325.* SHO-SHUM-PA, a cunning woman. Ingenious stories of female craft. *Leaf 326.* Mention made of the *Hbal-gumata* river, on the banks of which the priests of SHÁKYA used to exercise themselves.

*Leaf 326.* SHÁKYA in the *Nyagrodha* grove (near *Ser-skya* Sans. *Capila*). GAUTAMI', with 500 other women of the SHÁKYA race, goes to SHÁKYA, and begs of him to receive them into the religious order. He will not permit it, and recommends to them to remain in the secular state, to wear clean clothes. They will not desist. They follow him afterwards in his peregrination through the *Brija* country to *Nadika*. They beg him again and again to receive them. At last, on the request of KUN-DGAH-VO, (Sans. A'NANDA) he permits them to take the religious character. Several rules and instructions respecting the order of nuns. Various stories of these females that happened mostly at *Mnyan-yod* (Sans. *Shrávasti*).

*Leaf 488 to 524.* The story of PADMA-SNYING-PO, a celebrated Brahman, at *Hdod-pa-hi'hun-pa*, in *Kosala*. (This is repeated from the *K'ha* volume of the *Dulva*, leaf 155 to 192, whence the general tenor may be gathered.)

*Leaf 581.* SHÁKYA in his peregrination proceeds to *Gyad-yul*, the country of the Champions, and at *Rtsa-chan*, (the grassy, so called from the *kusha* grass,) the modern *Cámrú* or *Kámarupa*, in *Assam*, anciently the residence of the great king KUSHA-CHAN, stays for a certain time, under two *Sála* trees.

*Leaf 591.* The circumstances that preceded the death of SHÁKYA.

*Leaf 635 to 636.* The death of SHÁKYA. The principal acts of his life enumerated by HOD-SRUNG to VYAR-BYED, an officer of the king of *Magadha*, who instructs him how to inform the king of his decease (by representing, in pictures, the several scenes of his life.) Reflections on life, by several gods. The funeral raises disputes among eight tribes or cities, on account of the relics (*Shu-Gdung*) of SHÁKYA. They are pacified by having each their share. Chaityas are built for those relics.\*

*Leaf 667.* After the death of SHÁKYA, HOD-SRUNG, (Sans. KÁSHYAPA) becomes head of the sect. By his direction, five hundred accomplished priests, (Sans. *Arhan*, Tib. *Dgra-Bchom-pa*,) assemble in a place called the cave of the *Nyagrodha* tree, near *Rájagriha*, and make the first compilation of the doctrine taught by SHÁKYA. The *Mdo-sdé* or *Sútra* class, is compiled by KUN-DGAH-VO, (Sans. A'NANDA) The *Dulvá* (Sans. *Vindya*,) by NYE'-VÁR-HK'HOR (Sans. UPÁLI), the *Ma-mo*, or *Ch'hos-Mñon-pa-Mdsod* (Sans. *Abhidharma*) by HOD-SRUNG (Sans. KÁSHYAPA.) He presides over the sect for several years, appoints KUN-DGAH-VO his successor, and dies on the *Bya-gag-rkang* hill near *Rájagriha*. *Leaf 679.*

*Leaf 684.* KUN-DGAH-VO (Sans. A'NANDA) after having been for many years the head of the Baudha sect, intrusts the doctrine of SHÁKYA to

---

\* See my MS. Translation of *The death of SHÁKYA*.

SHANAHI-GOS-CHAN, appoints him his successor, and dies in the middle of the Ganges (on an imaginary island) between *Yangs-pa-chan* and *Magadha*. His body is divided into two parts. The one is taken by the *Lichabyi* race at *Yangs-pa-chan*, who erect a Chaitya to contain it: the other part by the king of *Magadha*, who likewise builds a Chaitya, at *Skya-snár-bu* (Sans. *Páataliputra*) over his share of relics.

*Leaf 687.* NYI-MAHI-GUNG is received into the religious order by KUN-DGAH-VO; is ordained and instructed how to introduce the faith into *Cáshmir*, as it had been foretold by SHÁKYA, *leaf 688.* How he civilized the Serpent race and their chief HULUTA:—how he planted and blessed the saffron there, and how he laid the foundation of the Bauddha religion in the *Cáshmir* country, one hundred years after the death of SHÁKYA, who had mentioned that country, as a suitable place for dwelling and contemplation.

*Leaf 690.* SHANAHI-GOS-CHAN intrusts the Bauddha doctrine to NYE'-SBAS;—he to DHITIKA;—he to NAG-PO—and he to LEGS-MT'HONG.

One hundred and ten years after the death of SHÁKYA the priests at *Yangs-pa-chan* violate in many respects his precepts.—Many disputes about trifles.—At last, seven hundred accomplished priests (Sans. *Arhan*, Tib. *Dgra-bchom-pa*) make a new compilation of the Bauddha works, to which was given, (something similar to our *Septuagint*,) the name of *Bdun-Brgyas-yang-dag-par-Brjod-pa*, “that has been very clearly expressed by the seven hundred” (accomplished priests.)

Thus ends the 11th volume, translated (in the 9th century) by VIDYAKARA PRABHA, and DHARMA SHRI PRABHA, pandits from India, and by the Tibetan *Lo-tsáva* (interpreter) BANDE-DPAL-HBYOR. On the three last leaves, from 706 to 708, are some remarks on the defects of these two volumes (by a Lama, NAM-MK'HAH-GRAGS in the monastery of *Snar-thang* not far from *Teshi-Lhun-po*) such as obsolete terms, bad translation, incorrect text, repetition of stories told before, &c. He advances several reasons, why the sacred volumes have been left in this state by the ancient reviewers.

TWELFTH AND THIRTEENTH (OF ३ *Na*, and ५ *Pa*) VOLUMES OF THE *Dulvá*.  
*The first has 458, the last 473 leaves. There are in the two volumes 64 books.*

*Title, Sans. Vináya Uttara grantha. Tib. Hdul-va-Gzhung-blama.*

*Eng. "The chief text-book (or last work) of religious discipline."*

*Subject, NYE-VÁR-HK'HOR (SANS. UPÁLI) the supposed compiler of the Dulva collection, puts to SHÁKYA several special cases, as to which class of transgressions particular faults or sins should be referred; or whether it be lawful to do or use such and such a thing. And SHÁKYA answers him as to each. He addresses SHÁKYA, by the term *Btsun-pa*. "Reverend!"*

NYE-VÁR-HK'HOR, in this last volume, is always mentioned by his Indian name UPÁLI, except in the eleven first books, which form a distinct work. At the end of this volume are the words *Upalis-kun-dris-pa rdsogs-so*,—"all the queries of UPÁLI are ended or finished."

The names of the translators or pandits of these two volumes are not mentioned. It is merely stated that they were translated in the time of KLUHI-RGYAL-MTS'HAN, a celebrated interpreter.

*Calcutta, 4th September, 1831.*

---

I may here close my Analysis of the *Dulvá* collection, from the tenor of which may in some measure be judged what is to be found in the remaining eighty-seven volumes of the *Kahgyur*. Of the whole of this voluminous compilation I have, however, prepared a detailed Analysis with occasional translations of such passages as excited curiosity, particularly the relation of the Life and Death of SHÁKYA. The whole are deposited in manuscript among the archives of the Asiatic Society, and will at any time be available to the scholar, who may also consult the first volume of the Society's Journal, page 375, for a general view of their contents by the late Secretary, Professor WILSON.

*20th October, 1835.*

## III.

---

---

ON THE

## ADMINISTRATION OF JUSTICE

## IN NEPÁL,

WITH SOME ACCOUNT OF THE SEVERAL COURTS, EXTENT OF THEIR  
JURISDICTION, AND MODES OF PROCEDURE.

---

By B. H. HODGSON, Esq.

*British Resident in Népal.*

---

THIS subject is one that possesses much interest whether for the legislator, the historian, or the philosopher. In Hindustán we look in vain for any traces of Hindú legislation or government. The Moslem conquerors have everywhere swept them away, and substituted their own practices and doctrines for those of the conquered. Even in Rájputána, it may be doubted whether we have the pure and unmixed practices of Hindu legislators and judges, or whether their necessary connection and intercourse with Muhammedan governments have not more or less modified their notions on these subjects, and introduced changes more or less considerable. But in Nepál at least we may be sure that nothing of this kind has occurred. Separated till very recently from any intercourse with Hindustán, shut up within their mountain fastnesses, the Nepálese have been enabled to preserve their institutions in all their Hindú purity; and undoubtedly, if we wish to enquire what are the features of the Hindú system of jurisprudence, it is in Nepál we must seek for the answer.

Mr. HODGSON is the first who has enabled us to obtain something like a precise and practical view of this complex subject. He has acquired his knowledge by dint of painful perseverance in submitting repeated written interrogatories to individuals who had either previously filled, or were then filling, the first judicial situations in Nepal. These individuals gave written answers to his inquiries; and from various motives they might be presumed to speak out fairly. One of these persons presided for many years with a high reputation for ability over the Supreme Court of Justice at Kathmándu. Another was the present *Dharmádhikári* of Nepal, a Brahman of great and various acquirements, and, from his situation, familiar with the legal administration of the country.

The information thus obtained was recorded by Mr. HODGSON, and transmitted by him to the Governor General in the form of a literal translation of the questions and their answers; to which were added, at separate times, several supplementary papers containing the result of his own local observation and research. The Governor General deemed the information collected by Mr. HODGSON of sufficient interest and importance to authorize its publication.

In attempting to arrange these valuable materials in a more connected and systematic form, any alterations or omissions in the original text have been scrupulously avoided, which might perhaps hazard the correctness of the details, or by taking from their freshness diminish their chance of interest with the earnest enquirer.

Some of the more remarkable features of the Hindú system of jurisprudence seem to call for notice in these preliminary lines, if only for the purpose of drawing the reader's attention to the subject, and furnishing him with an inducement, perhaps, to enter on an enquiry that promises well to reward any attention bestowed upon it.

The judicial system of the Nipálese appears to differ from our European system in having no separate jurisdictions or modes of proceeding for criminal trials and civil suits. Of the four Central Courts, as well as of

those of the provinces, each is competent to the dispatch of either business, and in the forms established there appears little distinguishable. Another feature of difference, and a highly important one, is the application of the trial by ordeal to the decisions of civil suits, where there is a want of evidence both oral and written. A third feature in which it differs from that of Europe is, the compelling the convicted criminal to confess; he being subjected to the torture of whipping till the desired result is obtained, without which he may not receive the full punishment of his offence. But the most peculiar feature of the system is that which belongs to it as the code of a Hindú people, I allude to the great importance attached to questions of caste, the cognizance of these being restricted to the highest Court (the *Inta Chapli*), in whatever part of the kingdom the subject matter originate. It may be doubted whether the system followed in all these Courts might not be improved by a closer approximation to European practice, but of some of the peculiarities which distinguish it, as compared at least with English jurisprudence, there can be as little doubt that we should do well to take a lesson from them.

Thus, the Nipálese are not so averse to receive proof of a criminal's guilt as we are. Provided he be *proved* guilty, they are not very particular as to the means. They consider in fact that the business of a judge is not to screen a criminal, but to convict him, and they deem the most satisfactory conviction of all, the voluntary confession of the criminal. Another particular which we might with great advantage adopt from them is, the celerity of their proceedings. No delay is ever suffered to take place as soon as a complaint is made, or information given; the parties with their witnesses are sought for, and, as soon as produced, the investigation proceeds at once to a conclusion. A third point worthy of our imitation is, their reception of each party's story in civil suits as told by himself, or of the prisoner's defence in criminal cases, without allowing a third person by his studied glosses to come between the judge and the truth. They appear to be sensible that manner as well as matter are to be



regarded, when we desire to judge of the good faith with which a statement is made.

In other particulars the Nepálese system appears to partake of the excellencies and defects of our own. Thus the prisoner in criminal cases has always the privilege of confronting his accusers, and of cross-examining them ; while on the other hand, in civil suits they have (considering the poverty of the country) as excellently graduated a scale of picking the pockets of both plaintiff and defendant, as is to be found in the practice of our own "reason-made-perfect" system.\*

There are other valuable peculiarities of the Nepálese system which deserve to be particularly noticed. Thus, it will be remarked, that the Courts seek in the first instance to reconcile parties, or to refer matters in dispute to arbitration. This natural and highly advantageous system, only recently made the practice of the English Courts, has prevailed in Nèpál for ages. Again, there are no rules of exclusion in regard to evidence. All is taken and rated only for what it is worth. Neither is there any restriction against parties becoming witnesses in their own causes,—speaking under similar penalties for false evidence as ordinary or external witnesses.

Oaths are very sparingly used, and in general rather as substitutes for evidence than as a means of validating it. This indeed is the most ancient and almost the universal acceptation of testimony on oath. It prevents as a consequence, in regard to witnesses, the adventitious crime of perjury or oath-breaking, leaving the more simple crime of false-witness in its place. But one of the chief practical benefits of the system lies in the sparing employment of records, which are never used for trivial objects. This is a chief cause of the quick dispatch of business which signalizes the Nèpál Courts, and effectually prevents arrears of business :—a marked contrast to our own Indian system wherein an over-weaning attachment to record is the source of dreadful expence and delay of justice.

---

\* Law is the perfection of reason.

The Nèpál Courts again are always sitting. They have neither vacations nor terms. This, too, and the extreme simplicity of the forms of procedure, which are full of reason and of efficacy, are principal causes of the quick dispatch of business.

The peculiar constitution of the Nepálese *panchayet* might furnish useful hints for its introduction under our Government, where hitherto it has not been found to work well; nor does the extension of the jury system to the Mofussil Courts promise to meet so clearly the habits and ideas of the people, as this simple and primitive organ of the administration of justice.\*

---

## ADMINISTRATION OF JUSTICE IN NÉPÁL.

### I. COURTS AT THE CAPITAL.

There are four courts of justice (*Nyáya Sabhá*) at Kathmandú. The first and chief is called *Kot Singh*; the 2d *Inta Chapli*; the 3d *Táksár*; and the 4th *Dhansár*:

#### § 2. Jurisdiction.

“† There are no regular limits placed to the jurisdiction, personal or local, of these courts, nor indeed of any court in Nèpál. Offences, however, involving the loss of life or limb, or confiscation of a man's whole substance, can be decided only in the *Inta Chapli*, whereto they must be *at once* transferred, for trial as well as sentence, if they originate in any

---

\* The above remarks were for the most part penned by the late Captain HERBERT, into whose hands the voluminous MSS, were placed by Mr. Secretary SWINTON, in order to be condensed and prepared for publication. They were afterwards arranged, and the interrogatory style broken down in order to save space, by the late Mr. G. M. BATTEN, Deputy Secretary to Government in the Political Department, and were finally submitted to the author for his approval and correction before publication. Mr. COLEBROOKE's account of Hindú Courts of Justice, in the *Trans. Roy. As. Soc. II.*, had not then appeared. J. P. Sec. As. Soc.

† Inverted commas denote where the author's manuscript is directly followed.

shape, in any other court of the Capital or its environs\* as they must be referred to it, prior to and for sentence, if they originate in any court of the mountains or of the *Taráí*. But all other causes of a criminal or quasi criminal nature, (such as trespass, assault, battery, slander, reviling, &c. which in Nèpál are punished by whipping, petty fines, and short imprisonment, and for which the plaintiff can never have a civil action of damages) may be heard in any of the four courts of Kathmandú, or in any court of the provinces—as may all civil actions whatever without limitation.”

§ 3. *Officers attached to the courts and their several functions.*

All the four courts are under the control of one, and the same supreme judge, called the *Ditha*.

There are two *Bicháris*, or judges for each of the three courts, *Kot Singh*, *Taksár*, and *Dhansár*, who conduct the interrogation of the parties and ascertain the truth of their statements. Subordinate to the *Bicháris* are the following executive officers :

For the *Kot Singh* or supreme civil court—

1 <i>Khardár</i> ,	1 <i>Jemadár</i> ,	2 <i>Amaldárs</i> , and
1 <i>Major</i> ,	2 <i>Havildárs</i> ,	40 <i>Sipáhís</i> .†

“The *Bicháris* are, originally and properly, the judges. They were so every where before the conquest. They are so still, except in the metropolitan courts. The *Ditha*, or president extraordinary of all the courts,

\* The great valley, and its immediate neighbourhood naturally form the peculiar domain of the Metropolitan Courts, but *definite legal* bounds of jurisdiction are unknown to the system and alien to its genius and character. The rivers *Dúd Cesi* and *Trisúl Ganga* are the eastern and western limits respectively of the local jurisdiction, in the first instance, of the Courts of the Capital. H.

† These military terms, current below, prove nothing against what has been noted above, as to the absolute independence of the civil institutions of Nèpál upon Moslem models. The *Gorkhas* borrowed their military system entirely from below, but from us not from the Moghels. Here and there indeed the Mussulman name of a civil functionary has crept into use of late, but is “*vox et præterea nihil*.” The *sipáhís*, are not regulars, but a sort of militia or provincials, exclusively attached to the courts. H.

is a badge of conquest; and his function, though by use now understood, is anomalous. Where he is not personally present, the *Bicháris* are judges. Where he is, they share his judicial functions as assessors; but chiefly enact at present, the part of our barristers. So the *military* menials of the court are excrescences and badges of conquest. The original ministerial agents were the *Mahun Naikiahs* and their *Mahániahs*—the *Tól-mals*, &c. &c., as set down under *Inta Chapli*.”

In each of the courts *Taksár* and *Dhansár*—

1 <i>Khardár</i> ,	2 <i>Amaldárs</i> ,
1 <i>Jemadár</i> ,	and
2 <i>Havildárs</i> ,	25 <i>Sipáhis</i> .

These officers serve processes\* in civil suits; see to the forthcoming of unwilling\* defendants and witnesses in such suits; and carry into execution the court's judgment.

The following officers belong to the *Inta Chapli* or supreme criminal court—

1 <i>Bichári</i> or Judge,	40 <i>Sipáhis</i> ,	16 <i>Kótwáls</i> ,
1 <i>Arazbègi</i> ,	2 <i>Mahánaikiahs</i> ,	2 <i>Kumhal-naikiahs</i> ,†
2 <i>Khardárs</i> ,	128 <i>Mahániahs</i> ,	1 <i>Tólpradhán</i> ,‡
2 <i>Jemadárs</i> ,	15 <i>Tól-mals</i> ,	1 <i>Pasalpradhán</i> ,
4 <i>Havildárs</i> ,	24 <i>Chokí-mahániahs</i> ,	2 <i>Tehvildárs</i> , and
4 <i>Amaldárs</i> ,	1 <i>Kotwál-naikiah</i> ,	6 <i>Bahidárs</i> .

The *Arazbègi* is the superintendent of the jail, and sheriff presiding over and answerable for executions. Immediately under him are the *Mahánaikiahs*, or superintendants of *Mahániahs*§ who search for and apprehend criminals, and execute almost all processes§ and sentences in civil and

\* See preceding note touching the *military* executive of the courts. H.

† The *Kumhal-naikiah* is head of the craft of potters; each craft has a head, but none has any special connection with the court. H.

‡ The *Tólpradhán* is not, properly, a judicial functionary: his duty is to levy the fixed tax of 1½ rupees upon each *Newár* merchant returning from *Bhote*. H.

§ See preceding remark. Here is plain proof that the military are accessory and mere badges of conquest, all functions being provided for *without them*. H.

criminal causes, carrying into effect the sentences of the courts, whether whipping or other. The *Máhánaikiah*s are always in attendance ; the *Máhániah*s attend by turns. They do not perform watch and ward ; that duty belongs to the military : but in case of disturbance actually commenced or hue and cry of theft, or other crime committed or attempted, being raised, they apprehend the offenders. There is a *Tol-mál* to or superintendent of each *Tól*, or ward of the city. If the presence of any person is needed in court, it is the *Tol-mál*'s business to identify the said person, and point out his residence to the *Máhániah*s, whose duty it is to secure him.

The *Choki-máhániah*s are the guards of the jail.

The *Kótwdls*, under their *Naikiah*, perform various kinds of menial service for the *Ditha* and *Bicháris* during their sitting in court. They attend by turns four at once. The *Tehvildár* has charge of all monies paid into the court on whatever ground. The *Bahidár* keeps the accounts of all such monies. The *Khardár* writes the *Kailnámah*s and *Rázínámah*s in each cause.

The judges and others attached to the courts receive salaries from the Government and take fees also.

The above courts sit for all the twelve months of the year, with the exception of a week or fortnight at the great autumnal and vernal festivals, *Dasahara* and *Diwáli*, when only they are closed.

They are always fixed, nor do any of the judicial authorities of *Kathmandú* make circuits : but the *Ditha* has the power of sending to any part of the kingdom special judges (*Bichári*.) to investigate official malversation and other particular cases when such occur.

“The *Ditha*, or supreme judge, personally presides over the *Kot Singh* and *Inta Chapli*, constantly and habitually, these two being in fact his own courts for the despatch (as we should say, though the term, as we shall soon see, would not actually pourtray the process,) of civil and criminal business respectively, and as well originally, without limit,

as by way of appeal in the last resort. The *Ditha* also sometimes goes to preside personally in the *Taksár* and *Dhansár* when any grave matter therein arising calls for his presence."

The subordination of the *Taksár* and *Dhansár* courts to the *Ditha* is illustrated at length by Mr. HODGSON in the following manner:—"The *Bicháris* of those courts hear, to a conclusion, all civil causes of whatever amount, that plaintiffs choose to bring before them. They also hear, to a conclusion, all complaints of wrongs done and suffered, save only such as entail a punishment touching life or limb, or involving total confiscation. But at the close of each day they are obliged to go to the *Ditha* and report, verbally merely and summarily, that such and such cases have come before them, and been heard, and that in their opinion such and such awards should be made. The *Ditha* may assent; and then the awards are made accordingly by the respective *Bicháris* next morning in the *Taksár* and *Dhansár* as the cases may have originated. Or the *Ditha* may dissent and direct in any case another decree, and *that* without desiring to know more of such case than is thus verbally set before him by the *Bichári* concerned. The *Bichári* may, in this event, if he please and be acute, argue the topic and perhaps convince the *Ditha* he is right and the *Ditha* wrong. Then again the award proposed by the *Bichári* will hold; else, the *Ditha* will either *immediately* direct another award; or he will do so, *after examining* any documentary evidence adduced in the cause and brought to him for perusal by the *Bichári*. But if neither the *Bichári's* verbal report of the case, nor the documents produced by them for summary examination by the *Ditha* afford him satisfaction (as however in 90 cases out of 100 they do) the *Ditha* will proceed to such *Bichári's* court and hear the cause anew,\* presiding himself in that court for the occasion. Such is the mode of the *Ditha's*

---

\* There is no want of leisure on the part of the *Ditha* to prevent his doing this, so often as may be necessary. Arrears of business are unknown to the courts of Nipál, and the current affairs of every court leave its judges at all times abundance of spare time. H.

ordinary control over the *Taksár* and *Dhansár* in cases where both parties assent to the judgments given in those courts. If either party dissent, then there is an appeal from the *Taksár* and *Dhansár* to the *Ditha* in the *Kot Singh*, and herein consists another step and degree of subordination in those courts to the *Ditha*. In appeals, as there are, now at least, no records or next to none (formerly recording to a small extent was in use) in any court of primary or superior jurisdiction, the original parties and witnesses must all proceed to the superior court. In regard to the *form* of the references which are necessarily made by the inferior courts of *Kathmandú* in all cases (and by the provincial courts, in all cases touching life or limb or the substance of a man's property) to the *Ditha* for his sentiments as to the award, even though there be as yet no appeal to him, judgment not having been in fact had, such references are made by the *Kathmandú Bicháris* by word of mouth simply and summarily, as above narrated; these *Bicháris*, moreover, in all cases, civil as well as criminal, necessarily producing at the same time the written acknowledgment or confession of the losing or offending party, signed by such party. This document has always a principal weight in settling the affair in the *Ditha's* opinion; but it will not bar the loser's or criminal's appeal to the *Ditha's* own court, either being allowed to allege and prove in appeal undue threats or violence in extorting such acknowledgement or confession."

The *Bicháris* of the *Taksár* and *Dhansár* cannot send any person to jail or put him in irons. They may only detain him in court pending the decision on his case, when if it be necessary to put him in irons or send him to jail it must be done with the sanction of the *Ditha*. They can, in general, fine to any extent by their own authority, but if they please they may refer a grave fine to the *Ditha* or *Bhárádár Sabhá* (Council of State.)

The *Ditha* in *Inta Chapli* can imprison a man for any number of months that may elapse from his confinement up to the annual ceremony called *Sráddh-páksh*, at which period the *Ditha* must report to the *Bhárádár Sabhá*, or Council of State, and take their sanction for each case of

further imprisonment. In general, the *Ditha* in *Inta Chapli* can fine to any extent without sanction of the *Bhâradâr Sabhâ*. Now and then a very grave case may be carried by the *Ditha* himself to the *Bhâradâr Sabhâ*, which then usually awards the fine suggested by him.

But the *Ditha* cannot inflict any punishment touching life or limb, or extending to total confiscation without first summarily reporting to and obtaining the sanction of the *Râj Bhâradâr Sabhâ* or *Râja* in Council.

#### § 4. *Other Courts at Kathmandû.*

Besides the four courts above described, there are two Courts of Registry—that for houses is called the *Chi-bhandêl*—and that for lands, the *Bhû-bhandêl*. All deeds of transfer of houses and lands are registered in these courts; and copies, with the *Lâl mohr* or State seal attached, furnished to the parties. No sale of house or land is valid till this copy is had. There is another court of special jurisdiction called the *Dafter-khâneh*, in which the disputes of the soldiery relative to the lands assigned to them for pay are investigated.

None of the above courts has criminal jurisdiction, and whatever penal offences may issue out of soldiers' claims, and claims relating to lands and houses, are carried to the *Inta Chapli*.

The *Bangya-baithak* or *Kumâri Chok*, at *Kathmandû*, is not a court of justice but the general record office of the fisc. A separate *Ditha* presides over it.

The whole of the courts of *Kathmandû* are situated within eighty or ninety paces of each other.

“The territorial limits of the metropolitan courts are the *Dûd Cosi*, East, and *Trisul Ganga*, West: but *Bhatgaon* and *Patan* have their own courts: and every where there are village courts. Its *inaccurate genius* is the chief characteristic of the *Nèpâl* judicial administration, as of that of the whole of Asia, and indeed of Europe until late years.”



## II. JUDICIAL ADMINISTRATION OF THE INTERIOR.

§ 5. *Local Courts.*

The valley of Nèpál being assumed as a centre, the interior or mountain districts are divided for judicial purposes into *Eastern* and *Western* parts, each of which is sub-divided, or liable to sub-division. At present to the eastward there is only one grand section, called from its boundaries the section of the *Mèchi* and *Dúd Cosi*. To the westward there are two large sections; the former of which is denominated the division of the *Káli* and *Bhèri*, and also the *Káli-pár* division: the latter is called the section of the *Káli* and *Marsyángdi*, and it is also known as the *Mánjh-khand* circuit.

Two *Bicháris*, acting together, preside over each of the greater divisions above laid down. Their courts are frequently ambulatory, but there are fixed judicial residences for them. In the greater eastern division there are two, one at *Mánjh-khand*, the other at *Chayanpur*. To the westward there are four:—two for the *Káli-pár* arrondissement, at *Báglung-chour* and at *Bèni*, and two for the *Mánjh-khand*, at *Pokhara* and at *Tárkú*.

The administrators of the *Tarái*, or low lands, appoint their own judicial authority (called *Faujdár*), who transacts with other business the administration of justice upon the old Moghel model. The *Faujdár's* appointment must be ratified by the *Darbár*.

For all the *Tarái* there are six *Súbahs* or general administrators; and under each *Súbah*, sometimes two, sometimes one, *Faujdár*.

For the division of *Morang*, there are one *Súbah* and two *Faujdárs*; for *Sabtari-Mohotari*, the same number; for *Bára Parsa*, the same; for *Routahat*, one *Súbah* and one *Faujdár*; for *Chitwan-Bèlvan*, the same; for *Botwál*, the same; for the *Doti-Tarái*, one *Faujdár*; for *Salliána*, the same. Each of the above divisions is independent of the rest.

The powers of the Provincial,\* or local, courts are always the same, not being regulated with reference to the rank of the Governor of the Province for the time being. But, in cases touching life or limb, or involving confiscation, breach of the laws of religion and loss of caste, every court of the interior must forward a *written* report with the offender's confession to *Kathmandú* to be laid before the Government which refers them to the *Ditha*. The *Ditha* reports the customary proceeding in such matters, and according to his report a royal command is transmitted to the local court to award such and such punishment, or to send the offender and witnesses to *Kathmandú*, as the case may be. No governor of a province or judge of a district court has power to decide cases involving loss of life or limb, or status, or substance of property, (*ját* and *páni*): to the decision of all others they are competent.

Military officers, fiscal officers, "courtiers," and others of whatever profession, are eligible to judicial situations in the provinces, if they have the confidence of government and are men of respectability and capable of the charge.

"The village courts of the interior are presided over by one *Prajá-naikiah* and four *Pradhán-Prajás*, popular chiefs of the spot, who now act in subordinate co-operation with a government agent or *Dwáriah*. Above them come the hill *Bicháris* of the two divisions already named:— and, instead thereof, in *Pálpá* and *Dúti*, the sudder court of the *governor*, and in the *Tarái*, that of the *Sabhá* or revenue administrator.

The *basis* of the judicial system in the interior is to be recognized in the village courts, composed of a *Naikiah* and 4 *Pradháns*: the *Dwáriah* is merely a badge of conquest.

---

\* The term Provincial rather implies a court of a vice-regal ruler of a large tract: there are none such in Nèpál save the Governors of *Dúti* and *Palpa*, and the *Súbahs* of the low lands. H.

§ 6. *Appeals.*

The supreme ordinary appeal court is the *Kot Singh*, but those who are dissatisfied with its decision can apply through the *Ditha* to the *Mahárája*, who in such cases directs the matter to be investigated in the *Kósi* or *Bhárádár Sabhá*, (Council of State). The result of this investigation when completed is reported through the chief minister to the prince who issues definitive orders on the case, which are usually such as the report suggests. On such occasions, if the case should be a grave one, relating to loss of *caste*, and such like, the *Bhárádárs* are assisted by the *Ditha* and *Bicháris* of the *Kot Singh*; and, if need be, by the *Dharmádhikári* also.

No one is at liberty to carry his complaint in the first instance to the *Bhárádár Sabhá*.

The appeal from the local courts of the interior lies in the first instance to the *Kot Singh* and thence to the *Bhárádár Sabhá* in the manner above described. But "the circumstance that in appeals from the provinces the parties and witnesses must all repair to *Kathmandú*; the extreme difficulties of the way; and lastly the impression naturally produced by the known fact that the local court (in all those grave cases wherein alone appeals might be resorted to) has already referred its judgment for sanction to the supreme court, all conspire to render appeals to the supreme tribunal very rare."

The inhabitants of *Dúti*, and those of *Pálpá* and *Salliánah*, (which form two large provincial governments, always held by the first subjects of the state with authority to nominate their own judicial functionaries) must first appeal to the sudder courts of their provincial governors, and revenue administrator respectively. In the mountains eastward of the great valley and westward too, with the above exceptions, the people's first appeal from their local courts is to the hill *Bicháris*, their second to the *Ditha* of *Kathmandú*.

Then there lies an appeal to the *Kot Singh* at *Kathmandú*, and finally to the Raja in Council: there is no separation of executive and judicial functions of government.

§ 7. *Courts of Bhatgaon and Patan.*

There are separate courts for the cities of *Patan* and *Bhatgaon*. Both places lie within the great valley, the former at the distance of two and the latter of eight miles from the capital.

The *Múl-Sabhá* or chief court of *Patan* and that of *Bhatgaon* cannot try the *Panch-khata*, or great crimes, involving peril of life or limb, or confiscation of a man's whole substance; but only offences punishable by trifling whippings or fines. Their local jurisdictions are equivalent with the limits of the lands attached respectively to the towns in question. There is an appeal from these courts to the chief court at *Kathmandú* and important cases are often referred by them in the first instance to the supreme court of the capital.

The officers attached to the *Múl-Sabhá* or *Pali-Sabhá* at *Patan*, are as follows: the *Dwáriáh* like the *Ditha* of *Kathmandú* is a supernumerary imposed by conquest over the head of the *Bichári* or true judge, and the *Pradháns* or chief townsmen, his assessors.

1 <i>Dwáriah</i> , who presides.	20 <i>Mahániahs</i> .
1 <i>Bichári</i> .	2 <i>Kotwál naikiahs</i> .
4 <i>Pradháns</i> .	24 <i>Kotwáls</i> .
1 <i>Bahídár</i> .	14 <i>Potadár Jaisís</i> .
1 <i>Patwári</i> .	8 <i>Pot Mahániahs</i> .
1 <i>Goshwára Tehwíldár</i> .	1 <i>Chaudarí</i> .
2 <i>Mahannaikiahs</i> .	1 <i>Si-chandèl</i> .

The constitution of the *Lám Pati* or chief court at *Bhatgaon*, does not materially differ, except in a few of the titles, as *Jua-Pradháns*, *Thecha Pradháns*, *Tuèr-naikiahs*, &c. The functions of the judicial officers have

been mostly described in § 3. The remainder belong to the fiscal. These courts being not merely seats of justice, but the centres of general administration.

The court of *Patan* called *Túsaal* resembles the *Bhu-bhandèl* of *Kathmandú*, and that called *Kund-bali Sabhá* answers to the *Chi-bhandel* of *Kathmandú*. They are, properly, courts of registration merely, but small actions relative to the boundaries of lands and houses, or to easements attaching to them, and small actions of debt also are tried in them.

The *Túsaal* court at *Bhatgaon*, like that of *Patan*, answers to the *Bhu-bhandel* of the capital, and that called *Karmi-Sabhá* to the *Chi-bhandel*. When land is transferred by sale, or mortgage, its limits are laid down by the professional measurers attached to the *Túsaal*, and the deed of sale is registered in the court, and a copy given to the buyer. As the boundaries of all lands are thus recorded in this court, disputes relative to them are referred to it, at least in the first instance.

It is unnecessary to particularize the establishments of these revenue courts which differ little from those above given.

There is a court at *Bhatgaon* called *Bandya-Pradhán* which has the exclusive cognizance of all disputes between the *Bandyas\** of that city, and their disputes alone can be heard in it.

#### § 8. *Police.*

There is no civil establishment of watchmen in the cities of *Nèpál*, but the military patrole the streets throughout the night. Night brawls and disturbances in the city are reported to the *Ditha* in the *Inta Chapli*.

The police of the villages is vested in the judicial officers described in § 4, the *Dwáriah*, 4 *Pradháns* and from 5 to 10 *Mahániahs* for each village, according to its size.

---

\* *Bandyas* are the *tonsured* and *regular* followers of the *Bauddha* faith.

The *Dwáriah* assisted by the *Múkhiah* or head villager\* also collects the revenues and settles all the village disputes. He is in fact the principal source of justice in the villages. His cognizance extends over all cases not included in the *Panch-khat*, nor touching life or limb, or the substance of a man's property. He cannot capitally condemn, maim, mutilate or confiscate. He can imprison, and punish with the corah, and fine. The extent of his local limits is not fixed : sometimes he presides over several villages ; sometimes over only one, if it be large.

The *Múkhiah* is the representative of the community, the *Dwáriah* of the government, both in matters of revenue and justice. The latter is the responsible person, but he acts with the assistance and advice of the former.

### III. FORMS OF PROCEDURE.

#### § 9. *Practice of the Courts.*

In civil suits, if the plaintiff be not forthcoming he is searched for, and if not immediately found, bail is taken from the defendant to appear when wanted, and he is let go ; but no decision is ever come to in such circumstances. If the defendant be the absent party, he is not on that account cast. He must be searched for, and until he is found, no decision can he come to.

The parties almost invariably plead *vivá voce*, but the plaintiff sometimes begins his suit with a written statement. They also almost universally tell their own tale ; but instances of a pleader (*Mukshár*), being employed have occurred, usually a near relative, and only when the principal was incapable. Professional or permanent pleaders are unknown. So

---

\* The head villager is called by the *Párbattiahs* the *Gaon Mukhiák* ; by the *Newárs*, *Naikiah* and *Pradhán Prajá* ; in the *Tarái*, the *Jèth ráyat*. The ryots are called *Prajás* in the hills both by *Párbattiahs* and *Newárs*. The *Dwáriah* is a title of the new dynasty. The duties of this officer and of the *Pradhán Praja* belong rather to the head of " Courts of Justice." H.

likewise are professional informers and public prosecutors. There are none of either. The casual informer is sole prosecutor. Evidence of oral testimony, of writings, of decisory oaths and oaths of purgation and imprecation, is admitted in all the four courts of the capital. Ordeal is only resorted to in grave cases, when oral and documentary evidence are wanting, but in such case the cause must be removed to the *Inta Chapli* if it should not have originated there.

The proceedings of each court remain in that court, excepting the accounts of the receipts on behalf of the state from the decision of suits; these are transferred periodically to the *Kumári Chok*.

“The first great object of the courts of Nèpál, when litigants come before them, is not trial, but reconciliation. The parties and witnesses all clamorously urge what occurs to them (never upon oath), and try their strength against each other. The general result of this apparently uncomely but really effectual procedure, is to bring the parties to an understanding, which the court takes care that the loser shall abide by. But if the court cannot thus succeed in bringing the parties to reconcile their difference or to submit it to the court’s summary arbitrament, upon a view of the animated exhibition just described, then, and then only, the trial in our sense begins: the first step of which is to bind the parties to the issue: for that is the meaning of *tháping* the *bèrí*, a ceremony which then takes place, and here, first, oaths are permitted; which very generally are used, *instead* of evidence, *not* to *confirm* evidence. If the testimony of external witnesses is readily forthcoming, it is taken and preferred. But in general, the parties themselves must look to that point well, for the court seldom cares to delay or to exert itself, in order that witnesses may appear. Neither the people nor the judges deem external witnesses the one thing indispensable. If such are not readily forthcoming to give decisive testimony, the court and country are agreed as to the propriety of at once resorting to other modes of proof; with which, though we were once familiar with them, justice is now deemed by us to have little connection. These

are,—decisory oaths of the parties, in civil causes, either party taking the oath at their pleasure ; purgatory oaths of the accused in *some* penal causes ; ordeals of various kinds, both in civil and criminal matters ; and lastly, *Pancháyáts*, chiefly applied, but not exclusively, to civil actions.

§ 10. *Course of a Civil Suit.*

Whoever has a complaint to make goes into court : the *Bichári* asks him against whom his plaint is, where the defendant is, and of what nature the plaint may be. The plaintiff explains, and then asks for a runner of the court to go with him, to whom he may point out the defendant. The *Bichári* gives the necessary order to the *jemadár*, the *jemadár* to the *havildár*, and the *havildár* to the *sipáhs*. The *sipáhi* ordered to go immediately demands 8 annas from the plaintiff ; which paid, he goes with him and arrests the defendant where the plaintiff points him out.

On the arrival of the defendant in court, the *Bichári* interrogates the parties face to face, and usually brings them to such an understanding as prevents the necessity of going to trial, in which case *pán phúl*, or some small fees only, are charged to them.

For instance, in a claim advanced for debt ; if the debtor, when called on by the court, acknowledges the debt, and states his willingness to pay as soon as he can collect the means, which he hopes to do in a few days—in this case, the *Bichári* will desire the creditor to wait a few days. The creditor may reply that he cannot wait, having immediate need of the money ; if so, one of the runners of the court is attached to the debtor, with directions to see the producing of the money in court by every means. The debtor must then produce money, or goods, or whatever property he has, and bring it into court. The *Ditha* and *Bicháris* then, calling to their assistance two or three merchants, proceed to appraise the goods produced in satisfaction of the debt, and immediately satisfy the debt, nor can the creditor object to their appraisal of the debtor's goods and chattels. In matters thus settled, that is where the defendant admits the cause of



action to be valid, from five per cent. to ten per cent. of the property litigated is taken (see § 14) and no more.

But if the parties cannot be brought to an understanding and persist in positive affirmation and denial, the plaintiff is commanded by the *Bichári* formally to pledge himself to prosecute his claim to a conclusion in the court wherein he is and no other. The words enjoining the plaintiff thus to gage himself are these, *béti\* thápo*, and the act consists in the plaintiff's taking a rupee in his hand and striking the earth with the closed hand, saying at the same time "my claim is just and I gage myself to prove it so." The defendant is then commanded to take up the gage of the plaintiff, or to pledge himself, similarly, duly to attend the court to the conclusion of the trial, which he does by formally denying the claim made against him, and upon this denial he likewise strikes the earth with his hand closed on a rupee. The rupee of the plaintiff and that of the defendant are deposited in court. The next step is for the court to take the fee, called *karpan*, of five rupees from either party. Both *béti* and *karpan* are the perquisites of the various officers of the court, and do not go to the government.

The giving of *karpan* by the parties implies that they desire to refer their dispute to the decision of the ordeal: and accordingly, as soon as the *karpan* is paid down, the *Ditha* acquaints the Government that the parties in a certain cause wish to undergo the ordeal. The order for them to undergo it is thereupon issued from the *Darbár*, but when it has reached the court, the *Ditha* and *Bicháris* first of all exhort the parties to come to an understanding and to seek the settlement of their dispute by *Pancháyat* or other means than ordeal, which if they will not do, the trial by ordeal is directed to proceed. (See § 15.)

---

\* *Béti* means a chain; the act of "tháping the *béti*" obliges the parties to persevere to a decree, and prevents them from withdrawing the action: the proceeds go to the *Bichári*. H.

§ 11. *Form of Procedure in a Criminal Cause.*

The process in a criminal suit may be illustrated by the following example :

If any one come into court and state that a certain person has killed such another by poison, sword, dagger, or otherwise, the informer is instantly interrogated by the court thus ; how ? when ? before whom ? the *corpus delicti* where ? &c. &c. He answers by pointing out all these particulars according to his knowledge of the facts, adducing the names of the witnesses, or saying that though he has no other witnesses than himself to the fact of murder, he pledges himself to prove it, or abide the consequences of a failure in the proof. This last engagement when tendered by the accuser is immediately reduced to writing to bind him the more effectually ; after which one or more *Sipáhis* of the court are sent with the informer to secure the murderer, and produce him and the testimony of the deed in court, which, when produced accordingly, is followed by an interrogation of the accused. If the accused confess the murder, there is no need to call evidence : but if he deny it, evidence is then gone into, and if the witnesses depose positively to their having seen the accused commit the murder, the accused is again asked what he has to say, and if he still refuse to confess, he is whipped into a confession ; which, when obtained, is reduced to writing and attested by the murderer. The murderer is then put in irons and sent to jail. Thus theft, robbery, incest, &c. are tried in Nèpál, and the convicts sent to prison. Each prisoner receives a daily allowance of a seer of parched rice and a few condiments.

§ 12. *Jail Delivery.*

“ The necessity of lustrating the city at the *Dasahara*, has had the casual consequence of causing a jail delivery to be held at that period. The jail (which is situated within the city,) must then be emptied at all events ; and it is usual to empty it judicially, disposing of the convicts who happen to be collected in the jail.

But this is neither the principal nor only delivery held during the year. In fact, the idea of *periodical* jail deliveries belongs to a system of migratory courts not always sitting, as that of *regular* deliveries does to an accurate system. The Nèpálese system of judicial administration is neither ambulatory nor accurate: but it has few and trivial delays, and offenders are speedily dealt with by judges who are always at their post, neither having vacations nor making circuits.”

When they amount to twenty or thirty, the *Ditha* makes out a calendar of their crimes, and adds thereto their confessions and statements of the customary punishments inflicted in such cases. This list the *Ditha* carries to the *Bhàradár Sabhá*, (Council of State) whence it is taken by the Premier to the Prince, after the *Ditha's* allotment of punishment to each convict has been ratified or another punishment substituted. The list so altered or ratified in the Council of State and referred by the Premier to the Prince is, as a matter of form, sanctioned by the Prince—after which it is re-delivered to the *Ditha*; who makes it over to the *Araz-bégi*—the *Araz-bégi* taking the prisoners and the *Mahán Naikiahs*, and some men of the *Pórya\** caste with him, proceeds to the banks of the *Bishenmoti*, where the sentence of the law is inflicted by the hands of *Póryas*, and in presence of the *Araz-bégi* and *Mahán Naikiahs*. Thus are grave offences involving the penalty of life or limb treated.

#### § 13. *Fees, Costs and Fines.*

No fee is taken from a plaintiff on the occasion of his commencing his pleading, or exhibiting a document. In civil causes, wherein the plaintiff's ground of action is not denied by the defendant and consequently it needs only to compel the latter to liquidate a claim of which he does not dispute the justice, *dasond-bisonnd*, or five per cent. to ten per cent. according to circumstances of the amount of property, as has been explained in the description of the procedure of a civil cause, is taken from the parties,

---

\* The vilest of the vile.

Where there is affirmation and denial by the parties and the trial of right must be had, then the charges called *bēri* and *karpan*, which have also been explained, attach ; and beyond these there are no other expenses attendant on the prosecution of civil suits.

The tax called *jītauri* means what is paid to the government in actions of debt and right from the winner ; and what is paid from the loser is called *hārauri*. *Jītauri* is ten per cent. upon the property litigated, and *hārauri* five per cent. ; *dasond-bisonḍ* and *jītauri-hārauri* are therefore nearly identical expressions ; the manner of their application requires more detailed illustration. In matters of debt and contrast in which the defendant (*Asāmi*) does not persist in denying the plaintiff's (*Sāhu*) claim, but only pleads present inability to pay, the Court, after the adducing of the plaintiff's books of account and other documentary evidence, takes *dasonḍ*, or ten per cent. of the property disputed from the plaintiff, and *bisonḍ*, or five per cent. from the defendant, on the settlement of the cause in court. If the debtor deny the debt, in any form of allegation, that is, if he say he never borrowed, or that he has paid the sum, and will not recede from his denial, and the debt be proved, by evidence or ordeal, then on the decision of the cause, *dasonḍ* of the debt is levied (as before) on the plaintiff, and the defendant suffers *dānd*\* (fine) more or less, according to the obstinacy of his falsehood. If the plaintiff, persisting in his allegation of a sum due, be cast ; and it be proved that there was no debt ; then the plaintiff or false accuser (*Pulāha*) suffers *dānd*, proportioned to the mischief or iniquity of the falsehood, and the falsely accused (*Saccha*)

---

\* *Dānd* is not by itself a punishment. Punishments (*Saxāna*) are, death, maiming or mutilating, imprisonment, and whipping with nettles or the corah, a true informer or accuser is not *Pulāha* ; a false and malicious informer or accuser is alone called (after conviction) *Pulāha*. If in the case supposed the crime he proved, the informer will receive a reward from the government under the name of *jītauri*, not pay a tax under that name. But if in such case the accusation be proved false, then the accuser will suffer *dānd*.

*Dānd* is not double of *jītauri*, but half of *dānd* is *jītauri* ; that is, the amount of *dānd* is that which is first decided according to circumstances, and is that which regulates the amount of *jītauri*. H.

gets *jítaurí*\* from the government : and thus in all cases of false allegation or accusation of property being wrongfully acquired, or false accusation of other sort or misdemeanor.

In offences involving loss of life or limb, or degradation of a Brahman from his caste, neither *jítaurí-háraurí*, nor *dasond-bísond* attach : confiscation of the offender's property follows. The *Sandhuah* or convicted felon suffers corporally ; and the informer goes free.

In cases of disputes in court between sons by marriage, regarding their shares, the court after awarding equal shares to all, takes *dasond* from all alike ; neither *bísond*, nor *jítaurí*, nor *dánd* attach. If the son by wedlock give not his share to the son by concubinage, and the matter come into court, the court awards to the latter a sixth share taking *dasond* from him : *phul-pán* or a petty fee is taken from the former, and nothing else. Sons by adoption, if of equal caste with the sons begotten in wedlock, get equal shares with them ; if of meaner caste, less. *Dasond* attaches to the portion awarded ; but neither *dánd* nor *jítaurí*.

Neither *dasond-bísond* nor *jítaurí-háraurí* attach in cases of action or prosecutions for creating nuisance, or for injuring or destroying public works of utility.

In cases of slander, and assault and battery, (for which there can be no civil action of damages) the offender suffers *dánd* proportioned to his offence ; the complainant does not pay *jítaurí* or any tax whatever.

#### § 14. *Rules of Evidence.*

Both in civil and criminal cases the court compels the attendance and deposition in the usual way of the witnesses summoned by the accused. As cases are heard and decided as soon as they occur, witnesses are

---

\* This *jítaurí*, ostensible a present is in many cases actually a small fee or tax. Thus : the party receives a turban worth two rupees and pays for it five rupees. But it is sometimes really a present, when the prosecutor is poor and meritorious ; in which case it is rated to cover his expenses during the prosecution, and to afford him a small reward to boot. H.

never obliged to attend long in the court. They therefore have no allowance whatever for food or travelling expenses.

A man of rank is treated with much consideration ; but ordinarily he is required to go into court and depose like one of the vulgar. Occasionally however an officer of the court is deputed to wait on him at his house, and to procure his evidence by interrogatories.

Women of rank are privileged from attendance : if their evidence be indispensable, some person who has the entrée of the *Zenánah* is deputed to hear their evidence and report it to the court.

Oral evidence is never reduced to writing at the time of utterance, nor recorded.

Documents produced in evidence remain in the court pending the dispute, and are returned to the owners when it is over.

Parties can always be witnesses in their own cases and always speak under the same penalties for falsehood as external witnesses.

An oath is never tendered to a witness in the first instance ; but if his evidence be contradictory or dissatisfactory to either of the parties, he is then sworn and required to depose afresh on oath. If he is a *Sivamárzi* or *Brahmanical Hindu* he is sworn on the *Hari Vansa* ; if a *Buddhist*, on the *Pancha Raksha* ; if a *Musulman*, on the *Korán*.

The form of swearing on the *Hari Vansa* is thus described. The *Bichári* of the court, having caused a spot of the ground of the court to be smeared with cow dung,\* and spread over with *pípal* leaves, and a necklace of *tulsi* beads to be placed on the neck of the witness, places the witness on the purified spot of ground, and causes him to repeat a *sloka* of which the meaning is “ whoso gives false evidence destroys his children and ancestors both body and soul, and his own earthly prosperity,” holding the *Hari Vansa* all the while on his head, and thus prepared he

---

\* This solemn oath is well worthy our attention. Oaths in Nèpál are used generally as substitutes for evidence rather than to confirm it : and the Bible, &c. prove that this was the primitive notion of an oath. H.

deposes. If there be reason to suppose that a witness is prevaricating or concealing some part of what he knows, he is imprisoned until he makes a full revelation.

Perjurers\* and suborners of perjury are fined or corporally, nay even capitally, punished, according to the importance or otherwise of the case, or the extent of the mischief done, and according also to the offender's caste.

In criminal cases, if the prisoner should volunteer a confession, that confession being taken down in writing and attested by himself, entirely supersedes the necessity of his trial; no witnesses are called to prove his guilt; moreover, if the prisoner should be fully convicted by evidence, his confession must nevertheless be had, taken down and signed by himself; and before such confession under his own hand is obtained, he cannot be punished. If he be sullenly silent, he is first scolded and menaced and frightened; if these means fail, he is flogged with the *corak*, until he confesses; and then his *kail-námah* is written.

He may always demand confrontation with his accuser, and cross-examine the evidence against him.

If in penal cases, he should persist in affirming his innocence, and declare that the accuser and his witnesses are his enemies, then he may have the ordeal, but he cannot purge himself by any sort of oath (*sapat kriya*).

In cases of signed and attested bonds, &c., if the attesting witnesses are dead, or not forthcoming, and no other satisfactory evidence is procurable, resort is had to ordeal. If in a case of debt the plaintiff produce a note of acknowledgment of the debt by the defendant, and the defendant deny the note to be his, and the fact cannot be ascertained by evidence as to his hand or any other sort of evidence, the defendant is brought by threats and scolding to admit the note as his, but if he persist in a denial,

---

\* Strictly speaking false testimony, not perjury, is the object of judicial vengeance. All objections to testimony go to the credibility—not to the competency; there being no recognised exclusions of evidence. H.

resort is had to ordeal. So it is in cases where the casual writing is in the hand of a third party, and not that of the defendant; if the parties cannot agree as to the authenticity of the note, and there is no other evidence in the cause, the decision of the case is referred to ordeal.

Tradesmen are allowed to adduce their entries in their books to prove debts to them. In general all mercantile affairs are referred to a *Pancháyat* of merchants, whose judgment is decisive upon conflicting entries, &c.

### § 15. Ordeal.

The ordeal is called *Nyáya*,\* and the form of it is as follows: Upon two bits of paper the names of the parties are respectively inscribed; the papers are rolled up into balls; the balls have *púja* offered to them; and from either party a fine† or fee of one rupee is taken. The balls are then affixed to staffs of reed, whereupon two annas‡ more are taken from each party. The reeds are then entrusted to two of the *havildárs* of the court to take to the Queen's tank,§ and with the *havildárs*, a *Bichári* of the court, a Brahman, and the parties, proceed to the tank; as likewise two men of the *Chámákhak* (or *Chumár*) caste. Arrived at the tank, the *Bichári* again exhorts the parties to avoid the ordeal by other settlement of the business, the truth of which lies in their own breasts. But if they insist on ordeal, the two *havildárs*, each with a reed, proceed one to the east, and the other to the west side of the tank, entering the water about knee-deep. The brahman, the parties, and the *Chámákhaks*, at this moment, all enter the water a little way, when the brahman performs *pújâ* to *Varuna*, in the name of the parties, and repeats a sacred text, the meaning of which is, that mankind know not what passes in the minds of each other, but that all

---

\* The word "*Nyáya*," "justice, right" is technically applied solely to ordeal. H.

† Called *Góla*. ‡ Called *Narkauli*.

§ This dipping in the Queen's tank is the most popular ordeal at present: but there are many others, similar to those formerly in use below, and indeed, all over the world. H.



inward thoughts and acts are known to the gods, SURYA and CHANDRA, and VARUNA and YAMA, and that they will do right between the parties to this dispute. When the *pújā* is over, the brahman gives the *tilak* to the two *Chámákkalaks* and says to them, "let the champion of truth win and let the false one's champion lose." This said, the brahman and the parties come out of the water. The *Chámákkalaks* then divide, one going to the place where one reed\* is erected, and the other, to the other reed. They then enter the deep water and at a signal given both immerse themselves at the same instant. Whoso first emerges from the water, the reed beside him is instantly destroyed with the scroll attached to it. The other reed is carried back to the court where the ball containing the scroll is opened and the scroll read. If the scroll bear the plaintiff's name, the plaintiff wins the cause; if the defendant's, the defendant is victorious. The fine, called *jítauri* is then paid by the winner, and that called *hárauri* by the loser; besides which, five rupees are demanded from the winner in return for a turban† which he gets; and the same sum, under the name of *Sabhá siddhah* (or purification of the court) from the loser. The above four demands on the parties, or *jítauri*, *hárauri*, *pagri*, and *Sabhá siddháh*, are government taxes; and exclusive of them eight annas must be paid to the *Mahániahs* of the court—eight annas more to the *Kotwáls*—and, lastly, eight more to the *Khardár* or register. In this manner multitudes of causes are decided by *Nyáya*, (ordeal) when the parties cannot be brought to agree upon the subject matter of dispute, and have no documentary or oral evidence to adduce.

#### § 16. *Pancháyat*.

The *Pancháyats* in use are of two kinds, domestic and public, the latter being called to settle suits come before the courts; the former to settle matters never brought under the court's cognizance.

---

\* "Markat."

† The turban fee is called *Pagri*.

Domestic *Pancháyats* are very popular, especially among merchants whose wealth attracts the cupidity of the courts, and the community of whom can, on the other hand, always furnish intelligent referees or *Panch* men.

To the public *Pancháyat*, all matters may be referred (with the exception of cases of life destroyed,) at the discretion of the courts, or at the desire of the parties: but cases of battery and assault are not usually referred to these tribunals.

The *Panch* men are appointed by the *Ditha*, at the solicitation of the parties, with whom solely the selection lies. After selection of their *Panch* men by the parties, the *Ditha* takes from them an obligation to abide by the award of the *Pancháyat*. The court or government never appoint *Pancháyats* of their own motion, except when men of note are under accusation; but if parties expressly solicit it, stating that they can get no satisfaction from their own *Panch* men, and give a petition to that effect to the government, the government will then appoint a *Pancháyat* to sit on the case. But no man can sit on a *Pancháyat* without the assent of both parties.

A *Pancháyat* of this sort often acts the part of a jury when men of note are accused, the government nominating the *Panch* men. In civil actions too the parties, tired of litigating, will sometimes desire the court or the government to nominate a *Pancháyat* to hear and decide without appeal. Ordinarily *Pancháyats* are chosen purely by the parties, and half the judicial business of the kingdom is performed by them to the satisfaction alike of the parties, the public and the government. The function of the *Panch* men appears to me to be essentially that of jurors. They find the verdict, and the court, out of which they issue and in which they assemble, merely enforces their finding.

The *Pancháyats* assemble in the court out of which they issue, and officers of the court are appointed to see that the *Panch* men attend daily and fully, with a view to prevent needless delay in the decision of causes

When such, however, does occur nevertheless, the matter is taken out of the hands of the *Pancháyat* and decided by the court which appointed it.

The *Pancháyat* has no power of its own to summon or to enforce the attendance of any person, to make an unwilling witness depose, or to secure the production of necessary papers. All such executive aid being afforded by the court appointing it; and in like manner the decision of this tribunal is referred for execution to the court. The assumption of any power of their own by the *Pancháyat* would be a grave offence.

The *Panch* are required to be unanimous. Such at least is the rule, but a very large majority will suffice in certain cases.

There are no permanent or established individual *Panch* men, but in all cases wherein *Párbattiahs* (Hindus of the mountains) are concerned, it is necessary to choose the *Panch* men out of the following distinguished tribes:—1st *Arjal*; 2d *Khadal*; 3d *Pandè*; 4th *Panth*; 5th *Boharah*; 6th *Rana*; one person being selected out of each tribe; and among the *Newárs*, the tribes from which *Panch* men must necessarily be chosen, are 1st *Maikè*; 2d *Bhanil*; 3d *Achár*; 4th *Srisht*. In matters affecting neither *Párbattiahs* nor *Newárs* there is no limit as to the selection by the parties of their *Panch* men; but old, learned, honest and experienced men may be supposed to have the preference. They receive no compensation for travelling expenses or loss of time, or on any account whatever. Indeed the very idea of compensating them is abhorred.

#### IV. THE LAW.

##### § 17. *Codes applicable to the different classes of inhabitants.*

Custom or precedent is the law in many cases; the *Dharmashástra*, or sacred canons, in many more; and the decision of numerous cases depends almost equally on both.

Infringements of the laws of caste fall under the *Shástras*. Other matters are almost entirely governed by the *Dès A'chár*, or customary law of the province of *Gorkhá*.

The customs of the *Bauddha* portion of *Newárs* are peculiar to themselves ; but in general the *Newárs* and *Párbattiahs* both acknowledge and are subject to the same *Dharmashástra*, although in some points there are appropriate usages for each.

It is not indispensably necessary that the *Ditha* should be versed in the law *Shástras*, but he must be acquainted with the principles of law and justice, and be a man of high respectability.

Neither is it required that the *Bicháris* should receive a regular legal training ; but they must always be well educated, of high character, practically acquainted with the law, and conversant with the customs of the country and the usage of its various tribes. And when a *Ditha* or *Bichári* is removed by rotation, or otherwise, he cannot retire till he has possessed his successor with a knowledge of the state of the court, and the general routine of procedure.

#### § 18. *Adoption, Inheritance, &c.*

Whoever would adopt a child must do so with the consent of all his near relations, and with the permission of some court of law, to which he must proceed, and in which he must complete the act. So, if he would alienate any portion of his property, by will, in favor of such adopted child, he must obtain, first of all, the consent of his heirs and perform the act in presence of a *Pancháyat*. In neither case, therefore, can there be, or in fact ever is there, a dispute and appeal to the courts of law. If any one in adopting a son and assigning to him property at his death, hath neglected the above prescribed forms, and a dispute therefrom arise and resort is had to the courts of justice, such dispute is settled by calling together several elders of the tribe to which the deceased belonged and taking their judgment upon the usage of that tribe ; which usage governs the court's decree. No man can adopt, or devise, at his own will and pleasure.

With regard to inheritance, also, the custom of each tribe is ascertained by reference to some of its elders, and that custom so ascertained

rules the judgment-seat in all cases of application to it. Amongst the *Khás* tribe, if a person have a son born in wedlock, that son is his heir: if he have no such son, his brothers and brother's male descendants are his heirs: his married daughters, or their progeny, never. If he have a virgin daughter, she is entitled to a marriage portion and no more. If he have a son by a concubine, and after his death his brothers and descendants do not conceal the deceased's wealth, but fairly state it to the bastard son, and give him a reasonable portion, the bastard son must, in such case, take what they give him, and he can get no more in any court; but if they conceal the deceased's wealth, and put off the bastard son with idle tales, assigning him no share whatever, then the bastard son, if he appeal to the courts, shall have all the deceased's property assigned to him, to the total exclusion of the family so attempting to defraud him. In short, the son by a concubine must have a reasonable share allotted to him by the family, though the exact amount will rest with them. If a *Khás* have a son, he cannot alienate a single rupee from him by will, either of ancestral or acquired wealth, save only, and in moderation, to pious uses; neither can a *Khás* adopt a son not of his kindred and make him his heir, if he have near blood relations. His first choice lies among his brother's sons and nearest relatives in the male line; his next among his daughter's sons and their male progeny: a stranger he can never adopt.

The *Magar*, *Gurung*, *Múrmí*, and *Kairanti* tribes agree with the *Khás* in respect to inheritance, adoption, and wills.

The *Siva-Margy* section of the *Newárs* agrees mostly with the *Parbattiahs* on all these heads. The *Buddha-Margy* section have some rule of their own. Among the *Newárs* of both persuasions, the son by a concubine gets one-sixth of the share of a son born in wedlock.

When cases of dispute on these topics are brought into court, the judge calls for the sentiments of the most respectable of the tribe to which the litigants belong, and follows their statement of the custom of their tribe.

§ 19. *Crimes and Punishments.*

The great crimes (technically called *Panch khat*) are those to which some of the following punishments are applied:—1, Confiscation of a man's entire property. 2, Cutting off ears and nose. 3, Amputating hands and feet. 4, Putting out eyes and emasculating. 5, Suspending by the heels from a tree till dead. 6, Flaying alive. 7, Death by hanging or decapitation, with the enslaving of wives and family, and forfeiture of whole property.\* The above punishments can only be inflicted by the chief court of each of the three cities (*Kathmandú; Bhatgaon, and Patan.*) The lesser adálat have power to cause the "touching† of the stone," to fine, to place under restraint, to send to prison, to inflict slight corporal punishments, and so forth.

---

\* A more methodical and complete enumeration of the great punishments, (*Panch Khata*—the word *Khata* being used to express as well the assigned penalty as the offence) is the following :

1, Death. 2, Mutilation. 3, Banishment. 4, Enslaving, or making over to some vile caste, the offender's wives and children. 5, Confiscation.

Nor is this enumeration of the chief offences the technical *Sastrika* one—but the more useful and practical enumeration derived from present usage modified by the original enumeration of the sacred law books. That enumeration is as follows :

1. *Brahm-hatya* or brahmanicide.
2. *Stri-hatya*, or woman killing.
3. *Bal-hatya*, or infanticide.
4. *Gao-hatya* or cow killing.
5. *Agamya-gavan* or incest in the peculiar Hindú sense. H.

† The *Dhunga Chúayi* or touching of a stone is this: When a cause is decided the *Bichári* orders a stone (any one) to be brought, and upon it a few blades of *Dúb* grass to be put. He then commands the loser of the cause to put a rupee and four dams on the stone and to touch it, observing to him "you have committed an offence against the *Mahárája* as well as the other party: that stone is the symbol of the Rája's feet, touch it, thereby acknowledging your offence, and be freed." The rupee put on the stone is the *Bichári's* perquisite, and the four dams, that of the *Mahárája*. This usage is not observed in every cause decided, but only when it is held that sin (*páp*) is necessarily attached to the losing party, and never in cases of ordeal. Others say that the stone has the "*charan*" or foot mark of the God VISHNU graved on it, (the *Satigrám*) and this account is more in harmony, with the usage of making atonement by an offering to it, than if it represented the sovereign of the state. H.

List of the chief offences above adverted to.

1 *Kalyán Dhan*, or treasure-trove, i. e. appropriating it. 2, Patricide. 3, Matricide. 4, Killing a Cow. 5, Killing a Brahman. 6, Killing a Woman. 7, Procuring Abortion. 8, Killing a *Gúrú*. 9, Incendiarism. 10, Poisoning. 11, Theft and Robbery. 12, Taking another's land by violence. 13, Seducing another's wife. 14, Murder. 15, Destroying Houses, &c. devoted to charitable and religious purposes. 16, *Agamya-gavan* or Incest.

1st.—*Kalyán Dhan* is treasure-trove of all sorts whatever ; including new mines. Secretly appropriating any such (which all belongs to the crown) is equivalent to theft, and is punished with death or confiscation in the chief *adhlat*. If death be awarded, the *Bickári* delivers the offender to the *Mahániah* and he to the *Poryas*, who execute the delinquent ; if confiscation be the sentence, then the *Mahániahs*, and the *Mahan Naikiahs* and the *Bahídárs*, and others, going to the delinquent's house take the delinquent's own share of the whole family property (lands as well as moveables), but spare the shares of the other members of the family.

To procure conviction in these cases, as in others, an informant (*Puláha*) is necessary, and then there are two parties to the cause, the informer (*Puláha*) and the accused (*Sandhuah*) whichever of them establishes his case, gets a *khilaat* from the *sirkár*, paying *pagrí* and *jítaurí*. If the informer loses, he is obliged to "touch the stone," and is fined with reference to the offence, and his means, more or less : (it is the custom to demand publicly twice as heavy a fine as is really taken) and the victorious accused, pays to the *sirkár* as *jítaurí* half the sum paid by the loser as *dánd* or fine. In the *Panch khat*, the *Kalyán Dhan* above described is held the greatest, and the ultimate decision of cases is peculiar to the *Mahárája*.

2nd. *Patricide*.—If any one, from the wantonness of youth, or selfishness, or avarice, or the instigation of his father's women, should put his aged father under restraint or imprison him, or starve him to death, such a wretch (*Sandhuah*) must have his property confiscated, and be put to death

by the *Poryas* (public executioners); if the wretch be a Brahman, his forelock must be shaved off; his thread broken; he must have a stripe of the hair on all four sides of his head shaved off; must be crammed with all forbidden food, and, in a word, utterly defiled and degraded; paraded thus through the whole city; his infamy proclaimed; and finally he must be driven out of the country, with confiscation of all his property.

3rd. *Matricide*.—This is punished like patricide.

4th. *Killing a cow*.—Punishment the same as for patricide; and if a Brahman, also as provided above.

5th. *Killing a Brahman*.—Ditto ditto.

6th. *Killing a woman*.—If any one should kill his wife on suspicion of having defiled his bed, the *Maháns*, having seized him, bring him before the court and he is beaten till he confesses, when he is obliged to “touch the stone,” his property is confiscated, and he is delivered to the *Poryas* for execution. If he has children, his children’s rights or shares are exempted, but all the rest of his property is confiscated.

7th. *Procuring abortion*.—If any husband depart on a journey, and his wife commit adultery in his absence; or if a widow become incontinent; or if a man inadvertently marry within the prohibited degrees, and, in any of these cases, the woman prove with child, and she and her paramour procure medicine and destroy the fruit of her womb; the woman, if proved guilty, is seized and maltreated till she confesses, and when by her confession the mediciner and the paramour are known, both are severely fined.

8th. *Killing a Guru, an elder brother, or a child*.—A person committing these crimes is seized and confined, and if on investigation he be proved guilty, he is delivered to the *Poryas* who conduct him through the city, proclaiming his sin and its penalty, and warning the people; and then, taking him forth from the city, execute him. His wife and children are given in slavery to the stranger, and his property confiscated.

9th. *Arson*.—Whoso sets fire to another’s house is punished with death.

10th. *Poisoning*.—This crime is also punished with death.



11th. 12th. and 13th.—*Theft, robbery, and seduction*.—If any one by violence take the property or land or wife of another, such an one is punished with heavy fines.\*

14th. *Murder*.—If any, from avarice, kill a man of wealth (*Sahu*), he is executed, and his property confiscated, and his wife and children made over in slavery to the stranger.

15th. *Sacrilege*.—Whoso destroys the religious works of another, as a *Dharma-sála*, or well, &c., founded for the good of his soul, such an one is severely punished and fined, according to the damage done: sometimes his whole property is confiscated.

16th. *Agamyā-gavan* or Incest.†—Whoso has sexual commerce with his *Guru's* wife or mother, or his father's lesser wife, or his son's wife, his property is confiscated and death is inflicted on him.

Whoso has sexual commerce with his daughter or with his daughter-in-law, he is, first of all, heavily fined or all his property is confiscated: then the male sinner is committed to the *Poryas*, conducted throughout the city, and expelled with his penis cut off: and the female has her nose and ears and pudendum cut off, and is then expelled the city; or else, she is given to be stuprated by fifty or one hundred or more men and then expelled. Incest with an elder brother's wife in his life-time is punished with very

---

\* The Hindu prejudice (in this case salutary) disinclines most of my informants to admit the fact that theft is ever punished with death. The ordinary punishment is certainly mutilation, repeated on a repetition of the offence. But it is certain that aggravated cases of theft and robbery (between which there is no technical distinction made) are often punished with death, and this indeed is expressly admitted in the preceding part of this paper. The description of theft in this place is strange enough, as is that of murder in the next paragraph. The just inference from such descriptions of these crimes is, that among these mountaineers, who are for the most part of fierce disposition and habits, the law has been obliged to exempt too many violent takings both of property and life from the ordinary definition and penalty of robbery and murder.—H.

† One branch of this subject is treated at length in a paper published by Mr. HODGSON in the *Journal of the Royal Asiatic Society of Great Britain and Ireland*, No. I, page 45, entitled "*On the law and legal practise of Nepál as regards familiar intercourse between a Hindú and an outcast.*" SEC.

heavy fines ; after levying which the younger brother may keep, if he will, the defiled wife whom the elder has put away.

To have commerce after his death, with an elder brother's wife is no crime whatever.\* In *Agamya-gavan*, from the father seven steps, and from the mother five grades, are forbidden. If any marry within them, the man's and the woman's father, and the go-between, all are fined, and the woman must be put away.

If any *Newár* wife, in her husband's life and whilst he is within *Nepál*, go astray, she and the adulterer are fined sixty rupees ; after which, the woman may go with either her husband, or the adulterer, as she pleases. If she prefers her husband (he willing) then the court shall take *pasu pán* from him ; and if she go with the other, then he shall have a second fine levied on him and take her.

If a *Newár* go to *Bhote*, and his wife remaining at his house or at the house of her father, should elope ; or, if her protectors (father, uncle, brother, &c.) should resolve to give her in marriage to another, her husband being (as before) in *Bhote*, in either case the wife must perform "*páchula*" that is, she must go to the *Mál Sabbá* of the city she belongs to (*Kathmandú*, or *Bhatgaon* or *Palan*), and present two *supáris* and one *mohr* (six and half annas) to the judge ; † when the judge sends the two *supáris* by the hands of a *Mahan* to the house of her husband. The *Mahan* having reached the house says to the relatives of the husband, " this is the *supári* of him who is gone to *Bhote*. His wife is divorced from him, and I therefore return you the instrument of the marriage contract (i. e. the *supári*.)" Then

---

\* This seems an interesting relic of the old customary law of India, requiring or permitting a younger, " to raise up seed" to an elder deceased brother, by marriage of the widow : such a custom still prevails in Orissa.

The custom itself would appear to be a relic of the still older and barbarous usage, which made the wife of one common to all the brothers, an usage which I have heard of doubtfully as prevailing in some parts of India, but which is unquestionably prevalent in *Bhote*.—H.

† Now, under the *Gorkhas*, a *Newár* wife cannot get free without paying two, four, or six, or more up to twenty rupees, according to her means.—H.

the wife returns all the ornaments, &c. given her by her husband, or if she delays in so doing, the *Mahan* compels restitution of them. The wife is then free to do as she wills ; but, still she is liable to fine (as all others are), if she have had sexual commerce with one of lower caste than herself.

If any *Newár* commits adultery with a *Newár* woman, whose husband is gone to *Bhote*, and the woman perform not *páchuki* then, supposing the caste of the parties to be the same and no relationship within the prohibited degrees to exist between them, they shall be fined in double the usual amount, or one hundred and twenty\* rupees : and then be suffered to go free, unless the adulterer be within the prohibited degrees of relationship to the adulteress. In that case he is put to death, or his whole property is confiscated ; or his penis is cut off ; and every sort of indignity and hardship heaped on him ; or he is let off with a fine proportioned to his means : the punishment being increased or decreased according to the nearness or otherwise of the relationship.

All such an adulterer's relations are obliged to go through the whole ceremonies of purification (*prayas-chitta*), paying all the allotted fees to the *Dharmádhikári*.

If the wife or daughter-in-law of a *Brahman* is defiled by a *Kshatriya*, or other of lower degree, such an one (the male) is decapitated and all his property confiscated. The *Brahmani* cannot regain her caste by performing *prayaschitta*, but falls into the caste of him who defiled her ; and so in case of a female of the *Kshatriya*, *Vaisya*, or *Sudra* being defiled by a male of lower degree. If a *Sudra* defile the daughter, &c. of a *Vaisya*, but his caste be such that the *Vaisya* could take water from his hand, then the *Sudra* is let off with heavy fines ; his life and property, for the rest, being spared. But if the *Sudra* be so vile that the *Vaisya* could not lawfully†

---

\* Here, as on all other occasions, this is the fine awarded to be paid, but only half of which actually is levied on the party.—H.

† List of the vile classes from whom no one can take water to drink—

*Kassai, Kusalliah, Porya, Dhobé, Kami, Damai, Kulu, Chama-khalak, Phugan, Massalman, Sondár, Sarki, &c.*—H.

drink water from his hand, then in such case the *Súdra* is decapitated and his property confiscated : and in this latter case all the *Vaisyas* of the city must perform *prayaschitta*.\*

If a *Brahman* defile a *Kshatriya's* or a *Vaisya's* or a pure *Súdra's* (whose water may be drank) daughter, it is no legal offence. If a *Brahman* or *Kshatriya* or *Vaisya* or pure *Súdra* violate the daughter of one of the vile classes ; then, if a *Brahman*, his whole property is confiscated and a stripe of hair shaved off all the four sides of his head, and he is expelled the country ; and all the four castes must perform *prayaschitta*. If a *Kshatriya* or *Vaisya* or *Súdra* do so, his life is forfeited as well as his property confiscated. If any one become enamoured of a lovely girl and he give her charms or philters, and medicines whereby he comes to enjoy her ; then he shall be made to "touch the stone" and be heavily fined : and the person who sold him the medicine or made the charms for him shall be fined also.

If any one corrupt and seduce the wife of any *Parbattiah*, (whether of the Brahmanical or other caste) such *Parbattiah* shall, if the case be clearly so, himself put the adulterer to death, and afterwards cut off the nose and hair of the adulteress, and turn her adrift. The injured husband, if he prove his injury, shall do all this without question, even though the slain adulterer be a *Brahman*.

But if the woman, when her husband would cut off her nose, can escape and prove her innocence before a court of justice ; then the murderer of the pretended adulterer shall be executed, and all his property confiscated. In case the *Parbattiah* adulteress have sinned with many men, then the *Parbattiah* husband shall only slay the *first* adulterer with his wife, and no other.

---

\* When a person is ordered to perform this purification he goes to the *Dhármaadhikári* and learns from him what rites are needful to be gone through. The *Dharmádhikári* writes him a prescription for their performance, and takes usually two rupees for it.—H.

If the stroke of the injured husband fail to kill the adulterer, and he turn on the husband and slay him, the adulterer shall escape punishment, and keep the woman to boot. Such is the usage among all the *Parbattiahs* so long as they marry among the *Parbattiahs*; but if a *Parbattiah* marry a *Newární*, he shall not have the privileges above described in respect to her. If any *Parbattiah* (*Khás* or *Magar*) marry the daughter of his maternal uncle, it is well, and even obligatory on the girl's parents if the man seek it: and the parents must wait his permission to marry her elsewhere. So, also, if the father's sister's son seek the mother's brother's daughter in marriage, the latter must assent, nor can she marry elsewhere till he has declared his disinclination; if such a person there be in existence. But if any *Newár* have any sexual commerce with the daughter of his maternal uncle, it is totally unlawful (by way of marriage or not), and he shall be severely fined.

*Assault.*—If two persons disagree, fall out, and one strike the other so as to bring blood, and he who has lost blood go to the court and complain, the court in case the charge is proved, shall make the blood-drawer “touch the stone” and fine him five rupees to the *Sirkár*.

*Fraud.*—If any one, having mortgaged his land or property to a creditor, afterwards mortgage it to a second creditor, and the case come before court, the court shall award the land or goods to the first creditor; but if the second creditor agree to pay the debt of the first creditor, the second may keep the pledged land or goods till the pledge is redeemed.

*Guti Lands.*—If any pledge his *Guti*\* land for money and spend that money, in such case both giver and taker of such pledge shall be fined.

---

\* *Guti* is land consecrated to the deity, a sort of mortmain remaining in the hand of the mortmainer and his descendants, (ostensibly for the use of such deity, but really for own use; the obligation to the god being liquidated by a petty annual offering to him,) is for security from rapacity of government or the prodigality of heirs. It is deemed more sacred than “*birtha*,” which is an offering to Brahmans, not to god himself, and is an alienation too. Whereas *Guti* is only ostensibly an alienation—in fact, an entail of the strictest kind on the descendants of the *Gutiyár*. It is neither partible among heirs, nor transferable in any degree.—H.

But if the taker of such pledge upon discovery of its being *Guti*, give it up, then he shall not be fined.

*Forgery.*—If any one, claiming under a deceased person, forge a bond of debt due to the deceased, and produce the bond and witnesses in court, demanding payment of debt as the representative of the deceased, and the forgery be proved, the court shall award the forger loss of his right hand and a heavy fine, and make him “touch the stone:” and from the other party they shall take *jítaurí* for the *Sirkár*.

*Swindling.*—If any one pretending to be the owner of land, pledge it and borrow money on it, and the taker of the pledge discover the fraud and complain in court: in case the matter is proved, the giver of such pledge shall have his hand cut off; the right owner of the land shall have his own; and the acceptor of the pledge be without remedy.

*Disputed Bonds.*—If the heirs of a dead man produce an obligation for money, all the witnesses to which are dead, and the debtor deny the bond, and no other evidence can be had;—if such a case be brought before the *Adúlat*, the court refers it to a *Pancháyat* or orders an ordeal, or tenders to the parties the decisory oath. Thus, if they be *Shiva-márgy Newárs*, it orders either of them to put the *Hari Vansa* on his head, and take up the money contested at his soul's peril if it be not his; or if they be *Bauddha-márgy*, it commands either to take the *Pancha Raksha* and do likewise. The tax on such issues is ten per cent. from the winner and five per cent. from the loser, or *dasond-bisond*, see § 13.

*Nepál Residency, 29th January, 1831.*

## IV.

---

# ESSAY

ON

## SANSCRIT ALLITERATION.

---

BY THE REV. WILLIAM YATES.

---

ALLITERATION is a subject, which in different eras of the world has engaged the attention and consumed the time of men of the most powerful minds, both in the East and in the West. In the dark ages, when men retired to monasteries, hermitages, deserts and caves, taking with them all the learning of their time, it excites no surprise, that they attempted to relieve the tedium of solitude, and to whet their ingenuity, by compositions which required the most vigorous efforts of intellect. It may be lamented that they were not employed in more profitable pursuits ; but it cannot be denied, that they have afforded the strongest proofs of skill and persevering labour. Owing, however, not to any want of capacity, but rather to a deficiency even in the Latin language when compared with the Sanscrit, the recluses of the West were never able to equal the sages of the East. Their alliterations appear to be confined chiefly to letters, and not to extend, as in Sanscrit, to syllables, to words, to pádas, and to whole stanzas. The following may be taken as a specimen of their attainments in this art :—

*Inter cuncta micans igniti sidera coeli,  
Expellit tenebras e toto Phoebus ut orbe ;  
Sic cæcas removit Jesus caliginis umbras,  
Vivicansque simul vero præcordia mota,  
Solem justiciæ se se probat esse beatus.*

The letters repeated, when read downwards, form the word Jesus three times, i. e. at the beginning, in the middle, and at the end.

Among the writers of this description in Europe, ALDHELM is one of the most celebrated. He lived at the time of the Saxon Heptarchy, and was thirty years governor of the monastery of Malmsbury. He devoted much time to the study of Latin prosody and alliteration; and is said to have produced a piece, which whether read upwards or downwards, forwards or backwards, was the same, like the third example of stanzas in artificial forms occurring in this essay. There is reason however to believe, though many ingenious pieces were produced in Europe, that alliteration was never reduced to a system as in Asia; and that ALDHELM, though one of the first writers of this class there, will not bear a strict comparison with KĀLIDĀSA of this country.

It is generally believed, that the celebrated poet KĀLIDĀSA lived near the commencement of the Christian era. He was one of the nine splendid gems that adorned the court of VIKRAMĀDITYA, and by the epithet *Kōlijita*, conqueror of millions, which was applied to him, it would seem that he was the chief. He wrote the *Nalodaya* for the purpose of exhibiting his unbounded skill in alliteration. In four books, containing on the average fifty-four stanzas each, he has given such illustrations of this subject as can never be surpassed.

This work has lately been published in Europe, with a Latin translation by a continental scholar, FERDINANDUS BENARY: but from the manner in which the text is printed, the grand design of KĀLIDĀSA is completely sacrificed; and from the manner in which the translation is made, his meaning appears to be, in many instances, most obscurely expressed, and sometimes entirely mistaken. No reason can be imagined, why KĀLIDĀSA should again write the history of King NALA and DAMAYANTĪ, after it had been so elegantly written in flowing verse by VYĀSA DEVA, except that he intended in this simple story to shew forth his ingenuity in alliteration; yet as his work has been printed in Europe, no person would suppose that it contained a single instance of such ingenuity. Since then it was the particular design of



this great poet, to illustrate this subject ; it will be proper in the first place to consider the different kinds of alliteration which his work contains.

The *Nalādaya* is for the most part written in verse measured by time, but is interspersed with verses measured by the number of syllables. The verses measured by time belong to the second class, first order, first genus, and ninth species of Sanscrit poetry. The genus is called **आर्ष्या** and the species **आर्ष्यागीति**. Each line contains thirty-two instants, with the poetic pause at the end of the third foot or twelfth instant. An instant is one short syllable ; a long syllable is two instants. In scanning this metre, only trisyllabic feet must be used ; with the exception of one dissyllabic, the spondee ; and one quadrisyllabic, the proceleusmatic. The sixth foot of each line, or of the second and fourth *pādas*, must be an amphibrach or proceleusmatic. The alliteration takes place in the first *pāda* immediately after the first foot ; and in the second *pāda* at the close ; in the third *pāda*, in like manner, after the first foot, and in the fourth at the close ; or in other words, the alliteration is found in the beginning of each line after the first foot and at the end. The first verse will serve as a general specimen for the whole, as—

उ॒उ॒उ॒उ॒|—|उ॒उ॒—|—|—|उ॒—उ॒|—|उ॒उ॒—  
**हृ॒द्य॒ स॒दा॒या॒ह॒वतः॒ पा॒पा॒ट॒व्या॒दु॒रा॒स॒दा॒या॒ह॒वतः॑ ।**  
 उ॒उ॒उ॒उ॒|—|उ॒उ॒—| उ॒उ॒—|—|उ॒—उ॒|—|उ॒उ॒—  
**अ॒रि॒स॒मु॒दा॒या॒ह॒वतः॒ त्रि॒ज॒ग॒न्ना॒गाः॒स्य॒रे॒ष॒दा॒या॒ह॒वतः॑ ॥**

*O my heart ! never depart from Yādava, the father of Love, who is the fire that burns the intolerable wood of sin, and who preserves the three worlds from all enemies.*

Though the preceding is the regular structure of the verses measured by time in the *Nalādaya*, yet there are one or two exceptions in the *position* of the letters repeated. In the first book the following exception occurs :—

सं॒गे॒न॒स॒स॒मा॒ना॒ न॒स॒स॒मा॒ना॒न॒भू॒त् क॒ति॒चि॒त्पु॒रु॒षा॒न् ।  
 त्रै॒ल॒ोक॒त॒म॒स॒स॒मा॒ना॒ न॒स॒स॒मा॒ना॒न॒भू॒त् तेषा॒भे॒दः ॥

*She saw there some men bright as fire, glorious and energetic ; and in appearance so like Nala, that there was no difference between them.*

The verses in the *Nalodaya*, measured by the number of the syllables, and interspersed with the others, are of the first class and of the first order of Sanscrit poetry ; and are either of the eighth genus, अनुष्टुभ्, consisting of eight syllables to the *páda*, and the fifth species, प्रमाषिका ; or of the twelfth genus, जगती, consisting of twelve syllables to the *páda*, and of the fifth species, तोटक. In scanning these metres the only feet employed are the *Iambus* and *Anapæst*. In the verses of these metres the alliteration is sometimes the same in all the four *pádas* ; but most commonly it is different in the third and fourth *pádas* to what it is in the first and second. The position of the repeated letters in each *páda* is determined by the choice of the poet. The following examples will illustrate these remarks:—

ॐ - ॐ - ॐ - ॐ - ॐ - ॐ - ॐ - ॐ -  
 वभौ ससारसगरसकाससारसर्द्धोः ।  
 मधुः ससारसारसदाससारसर्त्तवः ॥

*While he, a sea of excellence, and she, of a loving mind, were in their glory, the warbling flowery spring returned.*

ॐ ॐ - ॐ ॐ - ॐ ॐ ॐ ॐ - ॐ ॐ - ॐ ॐ - ॐ ॐ -  
 अपि चैत्य नगानवतानवता नवतानवतास्ततरा मधुना ।  
 इह सौख्यमगोचरमाचरमा चरमाचरमा चरमाचरमा न रम्यतरा ॥

*This river side is very beautiful, free from cranes, and adorned with flowers which have been tasted by the bees. What coyness is this of yours? said one who with gentle force and flattery led away his beloved.*

In these metres KÁLFDÁSA often confines the alliteration to two of the *pádas*, in which case, instead of repeating the letters twice, he repeats them four times. In all these instances the letters repeated form complete *pádas* :—as

पिको पिको पिको पिको वियोगिनीरभर्त्सयत् ।  
वर्षाधिभङ्गमाखापन् निता निता निता निता ॥

*'Twas as if some angry cuckoo was chiding the absent fair ones, and addressing them in broken accents.'*

नवमा नवमा नवमा नवमा गममाप समीच्छ वसन्तममः ।

भ्रमद् भ्रमद् भ्रमद् भ्रमद् भ्रमरच्छतः खलुकामिजमः ॥

*Did not the lover, gazing on the vernal sky, which, from the number of sportive busy bees, appeared covered with wandering clouds, meet with the object of his heart's desire?*

Those wishing to see other examples of the kinds of alliteration that have been here introduced, have only to refer to the *Nalbdaya*, where they will find them in abundance. The work, however, being confined entirely to the kinds that have been mentioned, does not supply a full exposition of the subject under consideration. It furnishes numerous examples of the first three orders of this species of poetry, and particularly of the third ; but not extending beyond these, it leaves untouched seven other orders which are necessary to complete the system. And even in the first three orders, it does not give examples of all the genera, and much less of all the species which they contain.

The subject of alliteration, therefore, deserves in this place a more minute consideration. It forms a distinct, and what may be denominated a third class of Sanscrit poetry, and may be used, as we have seen, in metres of any description, both of the first and second class.\* The name by which it is known is यमक *Yamaka*. In compositions of this nature, it is an invariable rule, that while the syllables to be repeated are left to the pleasure of the poet, in every repetition they must be employed in a different acceptation ; and if this rule is ever violated, it is at the expense of his ingenuity.

In this class of poetry there are ten orders, and in some of them several genera, species, and varieties, which we shall now proceed to specify.

1.—The first order is called अद्यपेत. In this the letters repeated occur together without any others intervening. It has four genera, determined by the number of *pádas* in which the alliteration occurs. We shall give one specimen of each genus. Every stanza or verse is divided into four parts,

---

\* For a description of these classes, see the Prosody of the author's Grammar.

called पादः *pādas* ; if the alliteration occurs only in one of these, it is of the first genus ; if in two, of the second ; if in three, of the third ; and if in four, of the fourth.

In the first genus there are several species, which arise from the position which the reiterated letters occupy in either of the four *pādas*. They may be placed at the beginning, in the middle, or at the end of the *pāda* as well as in the first, second, third, or fourth *pāda* at pleasure ; but to belong to this genus must occur in only one *pāda* : as,

राजन्वत्यःप्रजा जाता भवन्तं प्राप्य सत्पतिं ।  
चतुरमचतुरभोधिरसनेर्वीकरयहे ॥

*The people are happy in having you for their king : you who are distinguished in receiving taxes to the extent of the four seas.*

In the second genus there are six species, arising from the repetition of the letters together in two of the *pādas* ; as in the first and second ; the first and third ; the first and fourth ; the second and third ; the second and fourth ; or the third and fourth :

राजितैराजितैर्ह्येण जीयते तादृशैर्नृपैः ।  
नीयते च पुनस्तृप्तिं वसुधा वसुधारया ॥

*' May these glorious kings conquer in the dreadful battle—by whom the earth is filled with wealth.'*

In the third genus there are four species, arising from the repetition of the letters together in three of the *pādas* ; as in the first, second, and third ; the first, second, and fourth ; the first, third, and fourth ; or the second, third, and fourth : as,

आयता लम्बुखेनास्मानकथं नकथं जिते ।  
कमलं कमलं कुर्वदस्मिद्दस्मिन्प्रिये ॥

*O beloved, we are conquered by your beautiful countenance ; and why should not the lotus which adorns the water, surrounded with bees and full of petals, prevail, though it does not speak ?*

In the fourth genus there is only one species, which arises from the repetition of the letters together in each of the *pádas* : as,

सरसां सरसां परिमुच्यतनुं पततां पततां ककुभो वडवः ॥  
सकलैः सकलैः परितःकरुषै रुदितैरुदितै रिव खं निषितं ॥

*The whole heaven resounded with the many deep pitiable and wailing sounds of the birds, quitting the surface of the lakes and flying in all directions.*

The last three genera may have several species, arising from the position which the repeated letters occupy in the *páda*, as stated in the first genus. They may be placed at the beginning, middle, or end of each *páda*, at the pleasure of the poet.

2.—The second order is called *चपेत*. It differs from the former in the repetition of the letters with something intervening. It has four genera, which are distinguished by the repetition of the same letters, apart from each other, in one, two, three, or four *pádas*.

The repetition of letters apart in only one *páda* displays no skill in alliteration : it may happen by chance ; it is therefore unnecessary to give an example of this genus.

In the second genus there are six species, arising from the position which the repeated letters occupy, as in the first and second *pádas* ; the first and third ; the first and fourth ; or the second and third ; the second and fourth ; or the third and fourth : as

आरुह्यक्रीडमैलस्य चन्द्रकान्तसखीमिमां ।  
नृत्यत्येषससचारचन्द्रकान्तः त्रिखावसः ॥

*The peacock, having a beautiful shining tail, has ascended the crystal mount of pleasure, and is dancing.*

In the third genus there are four species, determined by the position which the repeated letters occupy in the first, second and third ; the first, second and fourth ; the first, third and fourth ; or the second, third and fourth *pádas* : as

करेणवोरणेवन्तकरेण द्विषतां हताः ।

करेणवः चरद्गता भान्ति सन्ध्याघनादिव ॥

*The enemy's elephants, killed by our destroying power, appeared by their flowing blood like a dark cloud reddened by the setting sun.*

In the fourth genus there is only one species—though there may be several varieties, from the position of the repeated letters in different parts of the *pádas* :

कमलेः समकोशन्ते कमले र्थाकरं मुखं ।

कमले ख्यं करोषित्वं कमले वोन्मदिष्णुषु ॥

*Your head of hair is like the bees (for blackness,) your face superior to the lotus ; and you among your lovers, like Lakshmi, enrich (your favourite.)*

In this order the repeated letters may be placed at the beginning, middle or end ; in the beginning and middle ; the beginning and end ; the middle and end ; or in all the three parts : as

अवसितं हसितं प्रसितं मुदा विससितं हसितं स्वरभासितं ।\*

नसमदाः समदा हतसमदाः पुरहितं विहितं नसमीहितं ॥

*Joyful laughter was destroyed ; the pleasures of love were diminished ; the disconsolate women were no longer cheerful ; and the welfare of the city was neglected.*

Besides the above, there are several other varieties in this order, arising from the use of two sets of repeated letters or words ; in which case the first *páda* agrees with the second, and the third with the fourth ; or the first with the third, and the second with the fourth ; or the first with the fourth, and the second with the third : as

उदितैरन्यपुष्टानामारुतैर्मे हतमनः ।

उदितैरपि ते दूति मारुतैरपिदक्षिणैः ॥

*By the cries of the cuckoo ; by the sound of your voice, my friend ; and by the blowing of the south winds, my heart is ravished.*

\* This is called चक्रवाच.

If in this order, the alliteration occurs at the beginning of each *páda*, it is called वृत्त ; if at the end पुष्य.

3.—The third order is called अक्षपेतक्षपेत, and is a union or mixture of the two preceding orders, having the same letters repeated both together and apart. The alliteration may consist of different letters, as in the first order ; or of the same letters, as in the second : and thus two genera are produced.

In the first genus, which consists of different letters repeated both together and apart, there are three species, as when the first *páda* agrees with the second, and the third with the fourth ; or the first with the third, and the second with the fourth ; or the first with the fourth, and the second with the third : as

कालम्कालमगलक्ष्य तारतारकमीक्षितुं ।  
तारतारम्यरक्षितं कालम्कालमहाघनं ॥

*What woman can bear to see the rainy season, when the stars are hid by clouds, when the loud thunder resounds, and the clouds are black as death ?*

In the second genus there are two species, as when the same letters are repeated both together and apart, in two or in four *pádas* : as

यामयामत्रयाधीनायामयामरणं निम्ना ।  
यामयामधिषा सार्था यामयामधितैवसा ॥

*We shall die by the night lengthened into nine hours, which though I have passed, still it is not gone.*

4.—The fourth order is called सन्दृष्ट or काञ्ची. In this the last letters of one *páda* correspond with the beginning of the next : as

पिञ्चिताग्निगामनुदिशं स्फुटर्ता स्फुटर्ता अगामपरिविह्वलता ।  
ह्वलताजनेनवह्वधा चरितं चरितं महत्वरहितंमहता ॥

*The bewilderment of the Rákshases wandering in all directions was manifest, and by their great leader, when routed, many unworthy deeds were done.*

5.—The fifth order is called समुद्र. In this order a comparison is instituted between the whole *pádas*.

There are four genera. The first has six species ; as when the first and second ; or first and third ; or first and fourth ; or second and third ; or second and fourth ; or third and fourth,\* *pádas* are alike, but not the remaining ones.

The second has three : as when the first is the same as the second, and the third as the fourth ; or when the first is the same as the third, and the second as the fourth ; or when the first is the same as the fourth, and the second as the third. The third has three: as when the first, second and third ; or the first, third and fourth ; or the second, third and fourth are alike.† The fourth has one, as when all the *pádas* are the same : as

नवानरैः परिक्रान्ता महद्भिर्भोजविक्रमैः ।

नवानरैः परिक्रान्ता ददाहमगरीकपिः ॥

*He burnt the city which was not accessible to the great and powerful monkeys, and which could not be reduced by men.*

समिद्धश्चरणादीप्ता देहेलङ्कामतेश्वरा ।

समिद्धश्चरणादीप्ता देहेलङ्कामतेश्वरा ॥

*Lanká (Ceylon) devoted to Siva, and having in it beautiful fine houses ; possessing absolute authority, and being inhabited by the destroyers of the sages, was burnt.*

बभौमरत्नान्विहृतःसमुद्रो बभौमरत्नान्विहृतेसमुद्रः ।

बभौमरत्नान्विहृतःसमुद्रो बभौमरत्नान्विहृतोसमुद्रः ॥

*Hanumán with the signet shone distinguished ;*

*Indra with his mistress, having been before defeated, was pleased ;*

*Old Ocean with his inferior deities being surpassed, was angry ;*

*And the joy-inspiring wind being changed, blew.*

\* The second, third, fourth, fifth and sixth of these species are called respectively, अयुष्मपाद्, विपद्य, गर्भ, युक्पाद्, मिथुन.

† The third is not reckoned a distinct genus by native writers, but is classed with the first, and considered only as an extension of it. The three genera of which examples are given are denominated, पादाभ्यास, चर्त्ताभ्यास, and सर्त्ताभ्यास, or सर्वसमक.



6.—The sixth order is called षडक्षी. It has a certain number of syllables reiterated alternately through the whole stanza. The distinctions in it arise from the number of the syllables that are repeated. The following is a specimen of the trisyllabic kind : as

नगजानगजा दयितादयिता विगतंविगतं खलितंखलितं।  
प्रमदाप्रमदा महतामहता मरणंमरणं समघात्समघात्॥

*The fine mountain elephants were not spared;  
An entire stop was put to the motion of the birds;  
All enjoyment was perfectly destroyed;  
The disconsolate women were deeply afflicted;  
And then the brave perished, but not in battle.*

7.—The seventh order is called प्रतिश्लोम.\* It has a given number of syllables, reading the same backwards and forwards.

Four kinds of it are enumerated. First, when one half *páda* reads backwards, the same as the next does forwards. Secondly, when one *páda* reads the same backwards as the next does forwards. Thirdly, when two *pádas* or one line reads backwards the same as the next does forwards. Fourthly, when one *ślóka* or stanza reads backwards the same as the next does forwards : as

नानाजाव वजानाना राजनौघ घनैजवा ॥

*That great army by its valour triumphed in many a battle.*

वारणागगभीरावा वाराभीगगषारवा।  
कारितारिवधासेना नामैश्चावरितारिका ॥

*That fine army, defended by huge elephants, resounding with the shouts of the fearless, intent upon fighting and destroying the enemy, is irresistible.*

नादिनोमदनाधीखानमेकाचनकामिता ।  
तामिकानचकामेन खाधीनादमनोदिना ॥

*The woman whose mind is not enchanted by the peacock's voice : who is bold and unsubdued by all-subduing love, is not the woman for me.*

\* This is also called सर्वतोभङ्ग by some, and placed under the head of दुष्कर.

निभितासिरतोभीकोन्वेजतेमरषारुषा । सारतोमविरोधीनखाभाषेभरवान्त ॥  
 तनुवारभषेभाखानधीरोविनतोरषा । चारुषारमतेजन्येकोभीतोरसितात्रिणि ॥

*O immortals ; the well armed, bold, glorious and warlike enemy does not tremble at our prowess. What fine, well mailed, broad chested, bold man, is acting the hero, unmoved in the loud resounding battle ?*

The following, written over the holy water in one of the churches in Paris, is a specimen of the kind in Greek ; with this difference, that the whole reads the same backwards and forwards, and has the same meaning both ways—*νιψον ανομηματα μη μοναν οψιν*—(wash your sins and not merely your face.)

The following is a specimen of the same kind in Latin.

*Roma tibi subito, motibus ibit amor.  
 Sole medere pede, ede, perede melos.*

There are instances of a like nature in Sanscrit. The following stanza reads the same backwards and forwards, and has the same meaning both ways.

सारमानवरारोहानगेभागमनाहिया । चाहिनामगभागेनहारोरावनमारषा ॥

*Is not this a beautiful woman, whose gait is like that of a large elephant ? She is adorned with her necklace, is gone into the grove, and let her lover follow.*

8.—The eighth order is महाजमक\*. In this every *páda* must be the same, and also every part of every *páda*; so that the same letters must be reiterated as many times as the nature of the verse requires, to fill up the whole stanza. There may of course be many kinds of this, arising from the number of syllables fixed upon for repetition, and the metre employed.

As the words or syllables repeated must occur in a different sense every time they are repeated, it is difficult to find such as can be reiterated through a whole stanza, and yet make good sense. The following is given as a specimen of this kind of composition, for the explanation of which I am

\* This term is applied by some writers to the next order.

indebted to Mr. WILSON. Though a misapplication of ingenuity, it serves the purpose for which it is here adduced, of explaining the nature of this description of alliteration.

समानया समानया समानया समानया ।  
समानया समानया समानया समानया ॥

*O thou ! who participatest in my feelings, effect the union of me, with this maiden, alike unparalleled by any ; in whom loveliness and accomplishments are combined ; but who is filled with haughtiness, and is indifferent to my sufferings.*

Analysis ;—समानयास a fellow sufferer, from समान and यास ;\* मां me, अनया with this (maid) ; समानयासमानया unparalleled in beauty and accomplishments, from स, मा, नय, and असमान ; समानय bring to or with, unite, सं, आ, and णी to lead ; असमानयाससमानया indifferent to my sufferings, असमान, यास and मान ; समानया haughty, स and मान.

9.—The ninth order is श्लोकाभ्यास. This requires one whole stanza to be the same as the next in sound, but different in sense. Strictly speaking, there can be only one kind of this ; the only distinction that can be made is that arising from the varied length of the stanza. The following are specimens of this description : as,

अभियातावतुरं कुंभुभृतं रश्मिरं पुरः ।  
कर्कशं प्रथितं धामससत्सुष्करेश्वरं ॥  
अभियातावरं तु कुंभुभृतं रश्मिरं पुरः ।  
कर्कशं प्रथितं धामससत्सुष्करेश्वरं ॥

*He will go to the good, great, handsome, rough chested, renowned, virtuous, excellent, blue-eyed king, ( Rāma.)*

*And in passing to the principal, lofty, enchanting, hard, inhabited mountain opposite, his splendour will be visible, for a season, in the sky.*

10.—The tenth order is called अनुप्रासवत्. This is only partial alliteration ; it has sometimes only the appearance of it, arising from some

\* यास same as आयास ॥

similarity in the sound of certain letters ; at others there is an alliteration, but it is irregular, and can be reduced to no definite rules : as

चितिविजितिस्त्रितिविहिति व्रतरतयःपरगतयः।

उरुररुधुर्गुरुधुवर्धुधि कुरवःखमरिकुलं ॥

*The noble Kurus, devoted to the conquering and preserving of the land, firmly opposed their enemies, and made them tremble in the battle.*

Besides the preceding there is another kind of alliteration called **दुष्कर**, by means of which the whole stanza may be thrown into some artificial form. The particular form into which the verse is thrown, gives to it both its character and name, as may be perceived by the instances which follow.

1.—The **गोमूत्रिका** has the syllables of the stanza so arranged as to read the same either straight forward, or cross-ways, following the order of the lines drawn from the first syllables. These lines are supposed to present a figure something like a stream of urine passing from a cow, and hence the name by which this kind of alliteration is denominated ; as

म वृत्ते विकषडा नं वा धने ष्विषादिभिः  
  
 व वृत्ते विकषडा नं युद्धमा ष्विषाणिभिः

*When the contest commenced with loud vociferations, the juice flowed copiously from the infuriated elephants engaged in the battle.*

2.—The **अर्द्धभ्रमक** after the stanza is regularly arranged according to its four *pādas*, or component parts, has the syllables so disposed that *the whole of the first half* reads the same straightforwards or downwards ; and *the whole of the second half* reads the same beginning with the first syllables forwards and the last syllables upwards ; as

अ	भी	क	म	ति	के	ने	दे
भी	ता	न	न्द	ख	ना	त्र	ने
क	न	स्य	का	म	से	ना	के
म	न्द	का	म	क	म	ख	ति

The stanza arranged in its common form reads thus—

अभीकमतिकेनेद्वे भीतानन्दखनात्रने ।  
कानसकामसेनाके मन्दकामकमस्यति ॥

*The field of battle is enlightened by the fearless; but destructive to the pleasures of the fearful; on it the brave shout for victory, and the base are put to flight.*

3.—The सर्वतोभद्र has each *páda* the same, whether read forward or backward, or from the centre to each extremity; while all the *pádas* together read the same either downwards or upwards, whether we commence at the centre or at each extremity: as

दे	वा	का	नि	नि	का	वा	दे
वा	हि	का	ख	ख	का	हि	वा
का	का	रे	भ	भ	रे	का	का
नि	ख	भ	व्य	व्य	भ	ख	नि

The verse in its usual form stands thus—

देवाकानिनि कावादे वाहिकाखखकाहिवा ।  
काकारेभ भरे काका निखभव्यव्यभखनि ॥

*O dastards; (see where) the rutting elephants are contending, exciting the gods to war, carrying the proud foes to warlike deeds, and shining (under the conduct of those who) save the conquering and the conquered.\**

4.—The मुरजबन्ध has the syllables so arranged, that when the stanza is divided into its four component parts, each part reads the same straight forwards, or crossways, like the braces of a *drum*; whence its name.

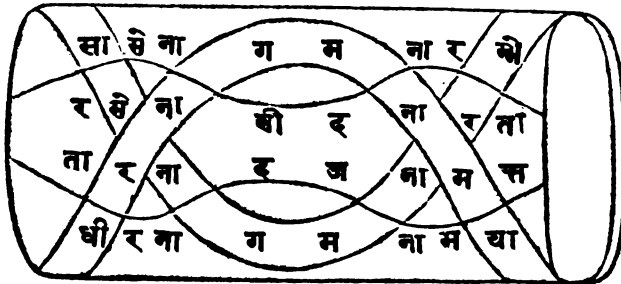

\* Literally the poor and the prosperous.

The verse in its regular form stands thus :

सासेनागमनारम्भे रसेनाधीद्वारता ।  
तारनादजनामस्त धीरनागमनामथा ॥

*The army at the commencement of the expedition was full of spirits; and with its infuriated elephants, vociferous and well conditioned.*

5. The चक्रबन्ध admits of the letters being arranged in the form of a *wheel* or *discus*, from which it takes its name. The letter that is repeated forms the axle from which the reading commences; reading first to the right, then downwards, again to the left and then upwards; afterwards from the top round the periphery. The first line of the verse forms the radii; and the second line, together with the letters at the end of each of the radii, forms the circumference; as—



The verse in its regular form reads thus—

करकुकोककुररकलहंसकरमितः ।  
सरोजकोमलोद्गारमीरसंसक्तमादतः ॥

*(A pond) adorned with deer, geese, quails and teals, and having its winds impregnated with the moist odours of the tender lotuses.*

The महाचक्र or कुलाचक्र, the *great* or *Potter's wheel*, differs from the preceding in being read from the axle along the radius upwards, then along the periphery to the left, and down the next radius to the axle. Then

commencing from the axle again it proceeds in like manner through the other three parts of the wheel—as will appear from the following example :—



राधाश्रुताखिवचना विरसाभिसारा रासाभिसारसमये विवृतापकारा ।

राकापतावृतपरायपयातमारा रामातया परमदुर्गलिताश्रुधारा ॥

*Radha hearing the words of her companions, and going joyfully according to appointment at the time of the festival, was dishonoured: and being truly devoted to her lord, was suffused with tears of grief that she was not rather killed.*

6.—The पद्मबन्ध is so composed that the stanza may be arranged in the form of a lotus, from which its name is derived. There are various kinds of it according to the number of petals assigned to the lotus. In this the syllable that is repeated forms the seed vessel, from which the reading commences towards the side E. and passing from thence (except at the cardinal points) to the next petal towards N. &c. In the petals to the cardinal points, the letters are read twice, once forwards and one backwards; as

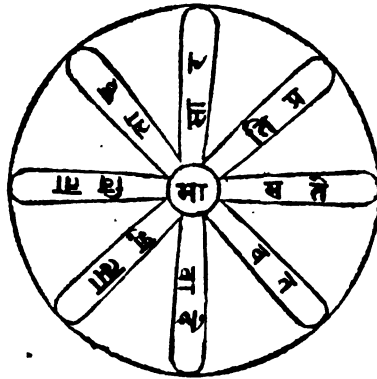

If the size of the lotus is enlarged by the admission of two stanzas into its composition, the construction is more simple, as in the following example, which is read right across according to the figures one, two, three, four. This was given me by a pundit applying for a situation as a teacher ; and the syllables beginning at one and going round to eight, form the motto *आमाके मने वरिवे* which in Bengálí means, *Forget me not.*

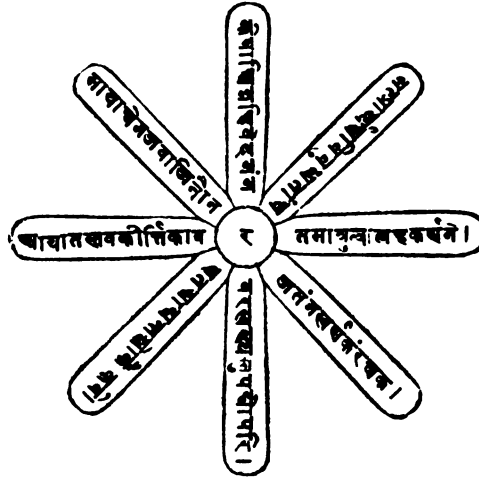

The following is the regular form of the stanzas and their rendering—

आयातस्वकीर्तिका वरतमाः श्रुत्वात्नरुक्षणं।  
 मायाचे गजवाजिनौ न रजतं न खर्षकं रक्षक॥  
 केषाञ्चिन्नहि वेदमं नरवरखस्वस्तु पद्योपरि।  
 मत्प्रार्थ्यञ्च विबुध्यतां चरणतस्याद्यन्त श्लोकैः कवे॥

*I, having heard of your great fame*

*By the hearing of the ear, have come (to see you);*

*I do not request of you either elephants or horses;*

*Neither, O Preserver! do I desire silver or gold;*

*I do not seek the infelicity of others;*

*But, Sir, your lasting prosperity.*

*You will understand, O Poet! the sum of all my desires,*

*By reading the first and last syllables of these stanzas.*



Compare with the preceding figure the stanza, which in its regular form reads thus—

मासते प्रतिभाषार रसाभाता हताविमा ।  
 भावितात्मा शुभावादे देवाभावततेषमा ॥

*O excellent for wisdom, your assembly shines distinguished for taste, full of splendour, high in spirit, expert at repartee, and divinely resplendent.*

7.—The खड्गबन्ध admits the stanzas to be thrown into the form of a sword, whence the name. The first stanza forms the blade, and the second the remaining part of the sword. Read first round the blade, and then the right, left, and central parts of the hilt.

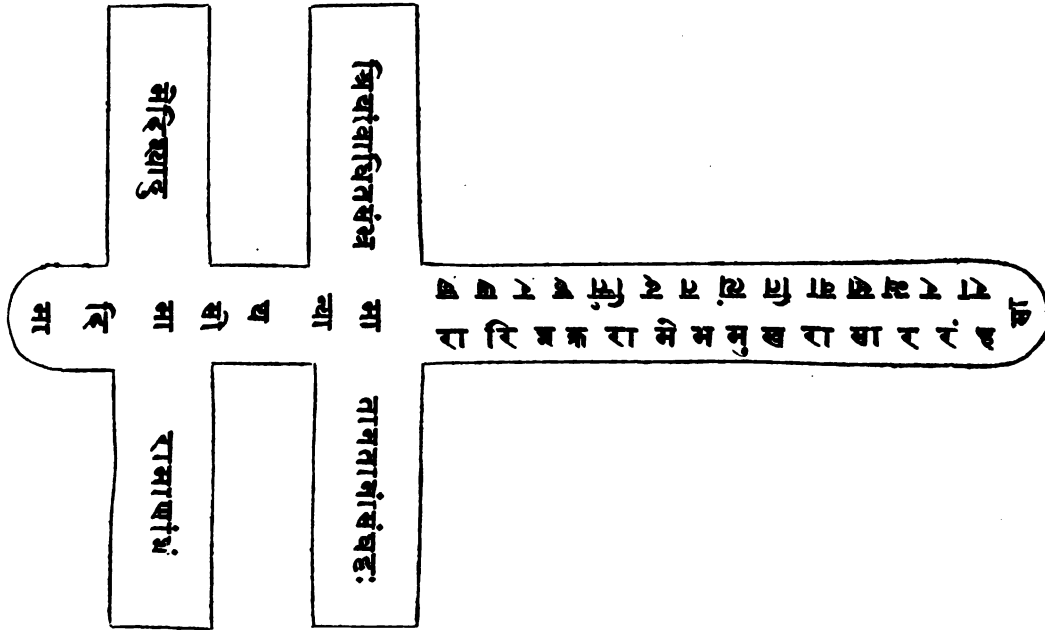

The following is the regular form of these words with their rendering:—

मारा रिरि क्रू रामे भ मुखे रा शार रं हसा ।  
 शार रं भुखे वा नित्यं तदतिहरषमा ॥  
 माता नानां संचटः मिथावाधितसभमा ।  
 मान्या य सो मा रामाणां मं मे दिश्यादुमादिमा ॥

*May the great Umā, who is continually praised in powerful strains by Siva, Indra, Rāma, and Ganesha; who is able to take away their pain; who is the mother of the devout, the*

*concentration of excellencies, the remover of fear, the venerable goddess, the glory of women, command my prosperity.*

8.—The धनुर्वन्ध presents the stanza in the form of a bow. The reading commences from the centre letter of the bowstring within the arrow, first to the right hand and then from the same letter to the left. After, from the centre letter of the bow, first to the right hand and then to the left ; as will be seen by comparing the verse which follows with the artificial form :

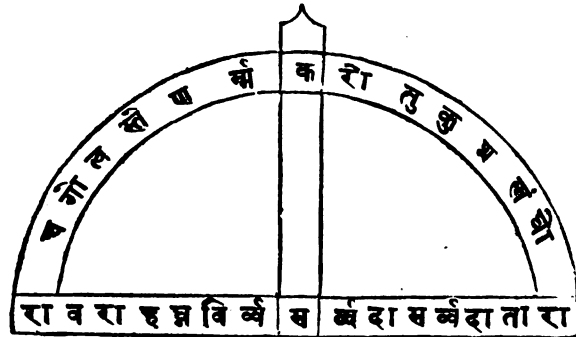

सर्वदा सर्वदा तारा सर्वविघ्नहरावरा ।  
करोतु कुशलं घोरा कर्षणखीलगोचरा ॥

*May the excellent goddess Tára, the constant giver of good and the remover of all hindrance, though tremendous and unattainable by your works, promote your welfare.*

9.—The स्रग्बन्ध is made in imitation of a necklace or rosary. The reading commences from the foremost bead, pearl, or jewel, and passing from that to the upper line goes round the string according to the figures. The letters in the first gem and all in the upper line, are read from the left to the centre, then upwards, downwards, back again to the centre and to the right, every syllable being repeated with the centre one. All in the second line from 7 to 12 are read from the right hand to the centre, then

downwards, upwards, back again to the centre and to the left, as will appear from comparing with the artificial form the stanza that follows :

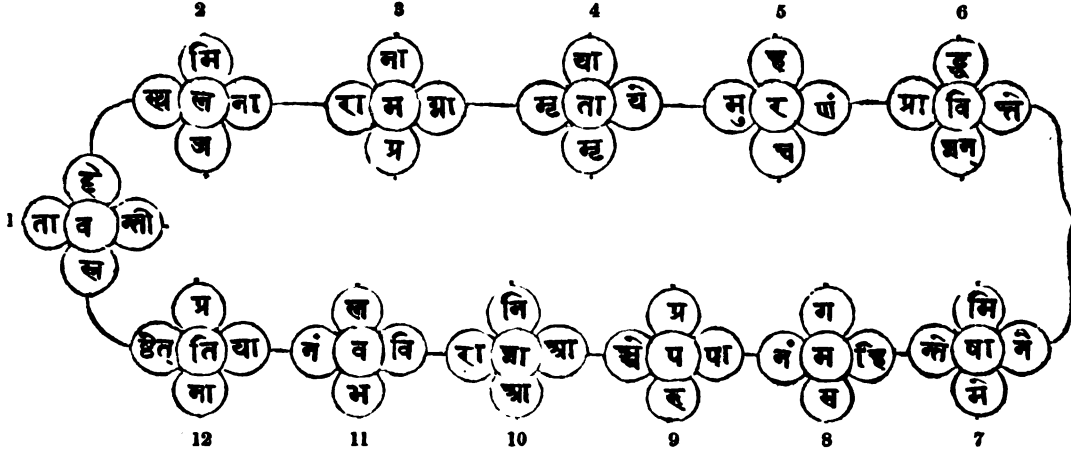

तावद्देवस्रवन्तीखस्रजस्रमिखना रामनामप्रमग्ना  
मृतायातामृता ये मुरहरचरणं प्राविष्णु विद्धु विन्ते।  
नैषामेषामिषान्ते हिमसमगमनं पापरूपप्रपद्ये  
आग्रा आग्राणिग्रा राविव भवस्रवभं चाति नातिप्रतिष्ठेत् ॥

*Know, O wise man, that those who come to the brink of the river of the gods, and repeating the name of Rāma depart to immortality, are absorbed in Vishnu ; they, like cold in winter, do not return to this sinful world ; their hope, like the horizon bright with the setting sun, obtains liberation from the world, and is no more disappointed.*

10.—The वृक्षबन्ध is of a more extensive form, and I am indebted to the Calcutta Christian Observer, August, 1835, for a specimen of it : it was composed by a pandit at Nadiya, and addressed to a Missionary. It is not quoted for the sense it contains, but as furnishing an example of a number of stanzas arranged in the form of a tree. The stem of the tree beginning from the top प, and going to the bottom ख, forms the first stanza. By taking the left hand side, and joining all the letters with the stem, other stanzas are produced, as चरनेश्वर, and so forth to the bottom of the stem.

Then अतमेश्वर, &c. &c. Afterwards by taking the right hand, and joining all those letters with the stem, other verses are produced, as चरमेश्वर and अधमेश्वर, &c. &c. In this manner thirty-four stanzas are contained in the small compass of this tree. The accompanying is the figure of the tree, copied from the original Sanscrit manuscript as nearly as it can be imitated in type.

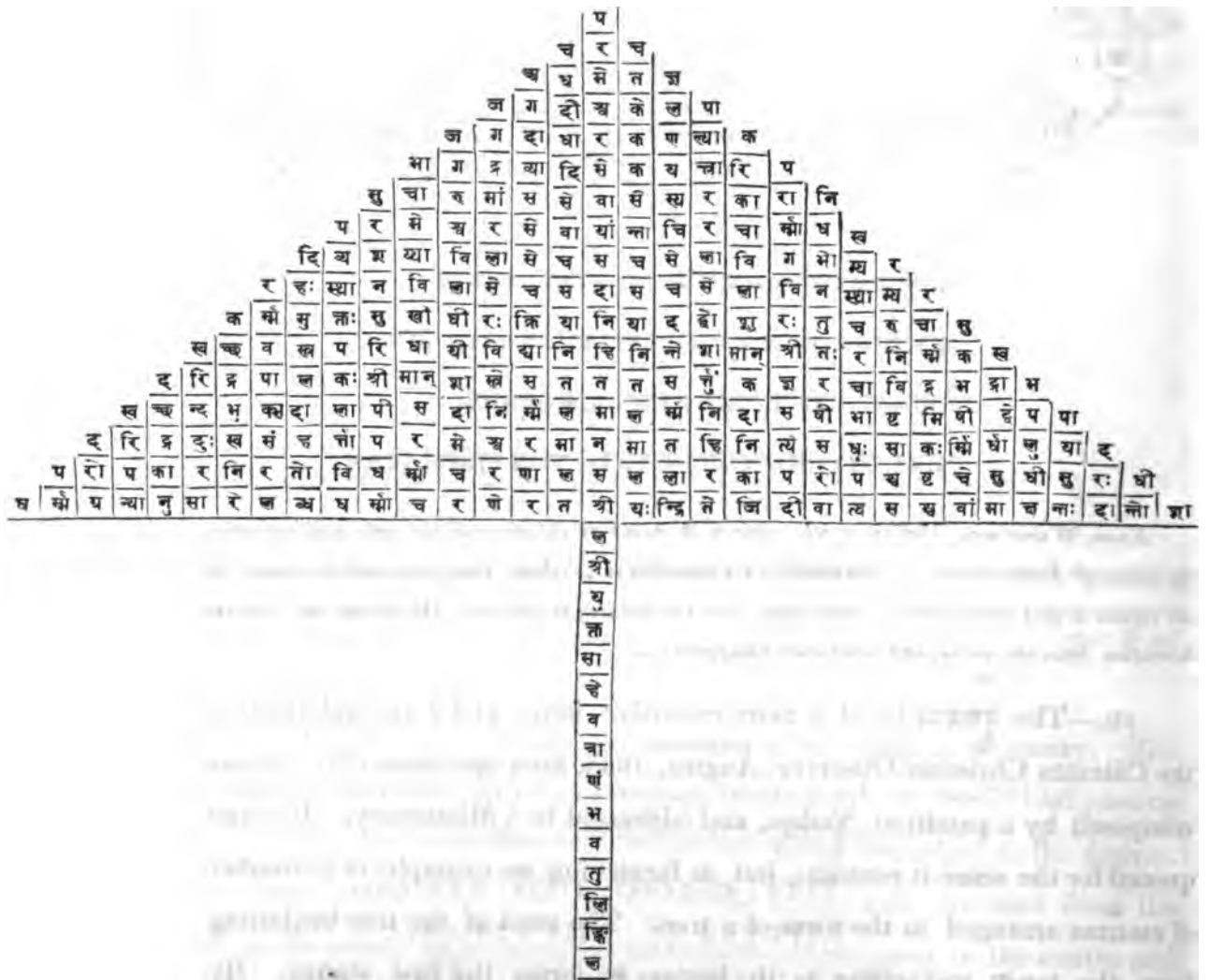

This has been literally rendered, and, as far as possible imitated in form, in the subjoined English version :—

<p>To the ultimate Being's          To the Lord of the lowliest's          To the universal Ruler's ser-          To the world-containing Deity's service          To all pleasurable delights ev-          To the enjoyment of agreeable food ever          To the worship of the Supreme Deity ear-          To reposing on beautiful couches, laudab-          To wandering in places of retirement          Full of merit, peaceful, grave, to good deeds in-          Clad in neat garments, with mind to wisdom devot-          Protector of the poor, prosperous, meditating the Shasters          Faring abundantly, right-spoken, and ever pure in          Removing the griefs of the poor, with mind fixed on God,          Delighting to aid others, slow to unbecoming behaviour, ex-          Devoted to virtue, following the instructions of the Shasters, excel-</p>	<p>To          God's          holy          ser-          vice          ev-          er          ear-          nest-          ly          in-          clin-          ed          in          heart,          ex-          cel-          lent,          and          hap-          py,          Sir!          may          Sal-          va-          tion          be          yours.          Amen!</p>	<p>Being's ultimate the To          Being's all-wise omniscient the To          ser- Deity's preserving all the To          service just good Bestower's the To          ev- Deity redeeming great the To          most Invisible the of worship the To          ear- duties proper your weigh to Maturely          just-enjoyment every of sweetness the taste To          fondly groves charming through rove To          in- compassionately upright, clever, Handsome,          dispos- meditation to happy, duties appropriate to Attached          prone ever ill and good of balancing the To          in clean ever and mild-spoken, Sin-hating          devoted, truth to, holy, righteous, Merciful,          ex- another help to slow not, diligent, intelligent, Sober,          excel- passions subdued of, truth speaking, patient, composed, Tranquil</p>
---	---	--

In addition to the different kinds of Alliteration which have been specified there is one other worthy of notice: it is that of forming stanzas with any given number of consonants. Verses are formed, from which half the letters of the alphabet are excluded, and others in which only one-fourth part of the consonants occurs. These are again reduced to three, two, and even one consonant. It might appear altogether impossible to compose an entire and intelligible verse by the aid of a single consonant; yet in Sanskrit this has been achieved. In the following stanza no consonant is used save द d, and it occurs no less than six and thirty times.

दाददो दुइदुहादी दादादो दूददीददः।  
 दुहादं दददे दुहे ददाद दददीददः॥

(Krishna) the benevolent, the troubler of the injurious, the purifier, whose arm is destructive to the impious; who gives both to the liberal and the miser, and is the destroyer of destroyers, discharged a weapon at the enemy.

In reference to the artificial specimens it may be observed, that since every form which pleases the imagination of the Poet may be selected as a kind of mould into which the verse may be cast or shaped, it is manifest that many other forms, beside those given, might be produced. Among these are commonly enumerated the flag, the dove-cot, the boat, the serpent, the earth, the door, the curls, the pond, the chain, the chariot, the sun or moon, and constellations, &c. Of all these I have not been able to obtain good specimens, and as most of them are of modern invention, and may be formed and increased at the pleasure of the Pandits, I have not deemed it of much importance to seek after them. The examples that have been supplied will be sufficient to explain the nature of this kind of poetry ; and taken in connection with the other ten orders, to shew that alliteration in Sanscrit, is a subject of no inconsiderable extent. I have not yet seen any thing in print on this curious topic ; it would be vanity therefore to suppose that I have exhausted it in this short attempt. Should what has here been advanced lead some scholar, better capable of fulfilling the task, to discuss it at a greater length, I shall consider that I have done more service to the cause of literature, and the objects of the Asiatic Society by prompting that individual to write, than by any thing I have written. The little information I have collected, has been gleaned with some trouble from different native works, there not being to my knowledge even among them a *complete* treatise on the subject.

I cannot conclude without observing, that the very ingenious specimens of alliteration which have been brought forward, must convince every unprejudiced mind that the natives of this country are by no means deficient in intellect. No nation has ever penetrated to a greater extent the

arcana of literature than the Hindus ; and no other nation has ever yet presented an equal variety of poetic compositions. The various metres of Greece and Rome have filled Europe with astonishment ; but what are these compared with the extensive range of Sanscrit metres under its three classes of poetical writing ? Whilst we thus place the Eastern sages far above all the Western bards for their skill in poetry, it must at the same time be regretted, that their attention to those parts of learning which required great ingenuity, diverted their minds from that correct and dignified style of prose composition in which the Greek and Latin writers so much excel them, and which to a nation is of far greater importance than all the embellishments of poetry.

The past ought to yield a lesson for the future. From the past the Hindus may learn that they have no reason to be discouraged in any literary undertaking, from the apprehension that they shall fail through the want of talent : only let them cultivate their minds to the extent of which they are capable, and they have nothing to fear from competition with any nation upon the earth. But for the future let them learn how much more it will be to their interest, both as individuals and as a people, to employ their talents in the noble pursuit of science, rather than in the abstruse, though ingenious parts of literature. Past experience has shewn, in the character of the English, that science can do more for a nation than literature ; and that both of them combined can work wonders. There was a time, as in the days of Aldhelm, when the English, like the Hindus, were more devoted to the recondite parts of school learning, than to the acquisition of sound scientific knowledge ; and had they continued so, they had never been what they are at the present period. Those dark ages have

rolled away, and the light of science and literature are now shining forth in their strength. That light has dawned on this land ; the Hindu youth are opening their eyes to behold its glories, and are commencing a career which will conduct them to honor and prosperity. Let them pursue their noble course with ardour and perseverance ; and may the time come, when they shall as much excel Europeans for their improvements in science, as their forefathers excelled them in the dark and deep parts of literature.

---



V.

---

TRANSLATION

OF AN

INSCRIPTION IN THE BURMESE LANGUAGE,

DISCOVERED

AT BUDDHA GAYA, IN 1833.

---

By LIEUTENANT-COLONEL H. BURNEY,

*British Resident in Ava.*

---

THE accompanying paper, (Plate I\*) is a *fac-simile* of an ancient Burmese inscription, which was discovered at *Buddha Gaya* by my brother, Captain GEORGE BURNEY, of the 38th Bengal Native Infantry, when he accompanied to that place in January 1833 the two Burmese Envoys who were lately residing in Bengal, on the part of the king of Ava. The black marble containing the inscription is fixed against the wall of the inner

---

\* The original fac-simile having by some accident been lost, Mr. V. HATHORNE, Judge of *Gaya*, was kind enough to have three more impressions taken with great care from the stone, which he states to be fixed into the wall in an inverted position. From these the present lithograph has been executed, marking the exterior margin of the letters as they now exist. This has been done with the greater care because a doubt exists as to the date on the stone; the short account given by myself in the *Journal of the Asiatic Society*, May 1834, from RATNA PAULA's reading, (without any knowledge of Colonel BURNEY's having taking up the examination of it) making it 200 years more recent than appears in the present translation.—J. P. SEC.

court of the convent of *Sanyásis*, mentioned in the 2d edition of HAMILTON'S East India Gazetteer, under the article *Buddha Gaya*. That building is called on the spot *Guru Māth*, and Captain BURNLEY was informed, that this inscription was discovered near the large Buddhist temple about forty years ago, whilst some labourers were excavating the earth for bricks with which to construct the convent, in the upper part of which lives the chief *Sanyási* or *Mahant* who now has charge of all the religious edifices and monumental relics of GAUDAMA to be seen at *Buddha Gaya*, and who receives presents and almost royal attentions from all Buddhist pilgrims.

The character in this inscription is styled by the Burmese, *Kyouk-tsa*,\* or stone letter, and it bears something of the same resemblance to the Burmese character in common use, as our own print does to our hand writing. The letters are square, whilst those of the common alphabet are round, and most of the inscriptions among the ruins of the thousands of temples in the old Burmese capital *Pagán*, as well as a remarkable inscription 183 years old, to be seen near the great pagoda of *Koung M, hoodau-gyee* opposite the city of Ava, which were supposed by former English travellers to be in the Pali character and language, are now known to be in the common Burmese language, but in this square alphabet. The following is a specimen of the difference between the two characters:—  
 တေ တေ တေ, *ta-youk*, a man, in the common Burmese writing, is တေ တေ တေ †  
 in the square character. It does not appear, that this kind of writing was ever in general use in Burmah, but there is one work now always written in a square character, slightly differing from that in this inscription. It is the *Kammua-tsa* (1), or rules for inducting a Burmese into the order of priest-

---

\* The letter here expressed by *ts* should, on analogy with the Devanágari, be written *ch*: In the same way the *th* should be *s*; the *z* should be *j*; the *y* frequently *r*; and the *d*, *t*. The author prefers the English rendering which gives the pronunciation nearest to the original, and his orthography has accordingly been preserved throughout the present paper. SEC.

† The 4th line of the inscription contains this word.

(1) Sanscrit. *Karma-váchyá*.

hood, translations from which are given in the Appendix No. 5, to SYMES's embassy to Ava, and in Dr. (BUCHANAN) HAMILTON's essay on the literature and religion of the Burmans, published in the 6th volume of the Asiatic Researches. The writing exhibited in SYMES's plate of the Burman alphabet as the Páli or religious text of the Burmans, is in the same square character; indeed, it is a sentence copied from the *Kammua-tsa*, which is usually written on plates of ivory or other substance with the Burmese varnish boiled, the plates being often gilded.\* The learned imagine that the square form of the letters rendering this character more easy to be cut, it was invented for lapidary inscriptions; or perhaps its closer resemblance to the ancient Páli alphabet may have led to its adoption. The Burmese possess eight or ten different kinds of *Kyok-tsa*, but most of them differ from the character in this inscription chiefly in ornamental additions.

As I possess and have read through a complete copy of the Burmese History in 39 volumes,† I have been enabled, with the assistance of some

\* SYMES has not copied the sentence quite correctly, and has omitted the first syllable of the first word. In the accompanying paper B. (Plate II.) the sentence may be seen written in both the square and the common Burmese characters. The *Kammua-tsa* is composed entirely in the Páli language, and held in great reverence, being used to administer an oath upon to a priest, and sometimes on solemn occasions to laymen. Those vowel marks which are placed above consonants in the common character, are often placed, slightly altered, on the same line with the consonants in the *Kammua-tsa* character, apparently because the lines in that kind of writing have very little space between them. This *Kammua-tsa* character is called "*Mag-yeze-ye*,"‡ Tamarind seed writing, because the letters are supposed to resemble that seed.

† The Burmese possess several histories of their own kings, as well as of the kings of Prome, Pagan, Pegu, Zenmay, Toung-ngoo and Ta-t,houng, relating fairly enough their disasters as well as successes, and bearing strong internal marks of authenticity, often supported by ancient stone inscriptions. About four years ago the present king of Ava appointed some of his most learned priests and officers to compile a new edition of the large Burmese History, called *Maha Yazawen-dau-gyee* (?). I possess a copy of this work in 39 volumes. It commences with the creation of the world, according to the Buddhist system of cosmogony, and after giving

‡ Perhaps a corruption of *Mágádkhí*, from the country where the writing was current. SEC.

(?) *Mahá Rája Wendógrí*.

learned Burmese at Rangoon, to give my brother the following translation with explanatory notes of this inscription. The letters do not appear originally to have been neatly or quite correctly cut, and some of them, as well as two of the numeral figures, are not formed according to any of the *Kyouk-tsa* known at Rangoon. Still as no word contains so many of these unknown letters as to render it impossible to be made out, the learned at Rangoon have had no difficulty in decyphering the whole inscription. The paper marked B. (Plate II.) contains a copy of it in the stone character, with all the letters made perfect and complete, as well as a copy in the common Burmese writing, and the following translation is as literal as the idioms of the two languages will admit. Not a single word of the Burmese is omitted, but it will be seen that several words in English have been added in order to preserve a grammatical construction. All such additional words are included within brackets :

“ (The temple of) *Páyatha-bhat*, <sup>(1)</sup> place of (GAUDAMA's) eating charitable offerings, (which was one) among the 84,000 temples of the great king named THEERI DHAMMA THAUKA, <sup>(2)</sup> who ruled over *Zaboodipa* <sup>(3)</sup> island, subsequently to (the year) 218 <sup>(4)</sup> of the Lord God's religion, having

---

some account of the kings of Magadha and Central India, and of the life of GAUDAMA, relates a history of the kings of Tagoung, Prome, Pagan, Pegu and Ava, coming down to the year 1821. The ground work of this compilation is taken from other histories written at various times, and principally from two works, copies of which I also possess. One is a very popular history in 20 volumes, comprising a period from the creation of the world down to the Burmese year 1073, (A. D. 1721) written by a private individual named MOUNG KULA, who is said to have died about the time that the Peguers took Ava in 1751. The other is a continuation of this history, compiled by an officer named PANA MENGYEE or MOUTTA MENGYEE, and comprises a period from 1711 to 1819, to the death of the late king, in 13 volumes. What Mr. CRAWFORD reported as to the account of the late war written by the royal historiographer at Ava, is a very good story, but I have the best reason for believing that he was incorrectly informed. There is no such officer at Ava as a special historiographer, and the portion continuing the history from 1821 to 1830 in 8 or 9 volumes, has only lately been completed by a committee of officers and learned men, whose labours have not yet been published. An abstract of the large history was prepared for me in 1830, by order of the king of Ava, and I then made a translation of it.

been destroyed for a long time, the Lord who repaired (it) was one PENTHAGOO-GYEE<sup>(5)</sup>. When afterwards (it was) again destroyed, king THADO<sup>(6)</sup> built (it). When afterwards (it) was again destroyed, and the Lord of the white Elephant, <sup>(7)</sup> the great king of righteousness, deputed (as) his representative the teacher THEERI DHAMMA PADA RÁJA GOONA, <sup>(8)</sup> (he) was accompanied at the time by (his) disciple THEERI KATHABA<sup>(8)</sup>. There was property to do (it), but (it) could not be done. Let the lord priest WARADATHI fulfil his engagement, and let PYOO-TA-THEIN-MEN<sup>(9)</sup> (or chief of 100,000 *Pyoos*,) assist, and have (it) done. Authority was given to PYOO-THAKHENNGE<sup>(10)</sup> and to the great officer RATHA, (and the temple) was re-built on Friday, the 10th day of the waning moon of *Pyatho*, <sup>(11)</sup> in the year 467<sup>(12)</sup>. On Sunday, the 8th day of the waxing moon *Tazoun-mhoun*<sup>(13)</sup>, in the year 468<sup>(14)</sup>, worship was paid (to the temple) with various flags<sup>(15)</sup> worthy to be presented. Worship was paid repeatedly with offerings<sup>(16)</sup> of food and a thousand lights. Reward was prayed for with 21<sup>(17)</sup> young persons considered as our own sons and daughters, and worship was paid with a *Padetha*<sup>(18)</sup> (tree), bearing flowers, cups and cloths. In order that the duty of (making) religious offerings might continue without interruption throughout all time, purchase was made with the weight of our bodies<sup>(19)</sup>, and bestowed (on the temple). May such good works become (our) aid (to obtain) the thing *Neibban*<sup>(20)</sup>, and (we) desire the reward of becoming *Rahandas*<sup>(21)</sup> (or inspired apostles), in the days of the Lord God ARIMADEYA<sup>(22)</sup>.”

### *Explanatory Notes.*

1.—*Páyatha-bhat* † are said to be Páli words, meaning boiled rice and milk. The first charitable offering which GAUDAMA received after he issued from the wilderness, where he had been performing austerities during six years, was in a village called *Thenanigoun*, from a rich man's daughter named THOOZÁTA. It consisted of boiled rice and

---

† *S. Páyasa.*      (°) *Sri Kasyapa.*

milk, and the spot where he ate <sup>(a)</sup> it was called *Payatha-bhat* afterwards. That spot was close to the right bank of the *Nareenjana* <sup>(b)</sup>, now called *Nilajan* stream, into which GAUDAMA cast the gold plate containing the food, after having eaten forty-nine mouthfuls of it. The plate floated up the stream and gave a proof that GAUDAMA would become a Buddha. On this same spot a king of *Magadha* named THEERI DHAMMA THAUKA, built one of the 84,000 temples, which he raised to the memory of GAUDAMA 218 years after that Buddha's death. The monuments usually called, as in this inscription, *Tsedi* or *Zedi* <sup>(c)</sup>, are now generally built in Burmah, of a round and solid form, like that of the Dagope in Western India, but in former times, as may be seen particularly at Pagan, they were much handsomer structures, being arched, and containing highly ornamental apartments within them. At Pagan there still exists one pagoda called *Them-bau-zedi* <sup>(d)</sup>, or ship-temple, probably from the circumstance of the form having been taken from that in use in countries beyond sea, which is something like the large Buddhist temple at *Buddha Gaya*, described in HAMILTON'S East India Gazetteer as "a lofty brick edifice resembling at a distance a huge glass house." The Burmese envoys had a picture taken in order to be presented to the king of Ava of this edifice, and of most of the surrounding objects at *Buddha Gaya*. THEERI DHAMMA THAUKA <sup>(e)</sup> built a monastery as well as a temple in 84,000 different parts of his empire, and as the temple now standing at *Buddha Gaya* called by the Burmese *Mahá Baudhi Paribauga Zedi* <sup>(f)</sup> (temple in which all offerings to Buddha's sacred tree are deposited), is considered by the Burmese vakeels to have been originally built by the king of *Magadha*, they suppose that the inscription refers to the monastery which was built at the same time, and which might have been styled *Páyatha-bhat*, but of which there are no remains now. The words of the inscription do not however quite warrant such a supposition.

2.—THEERI DHAMMA THAUKA was the grandson of TSANDA-GOUTTA, <sup>(g)</sup> who must be the same as CHANDRA-GUPTA, king of *Magadha* of Sanscrit authors, and SANDRACOPTOS, or SANDRACOTTOS of the historians of Alexander the Great. According to the Burmese history, TSANDA-GOUTTA reigned for 24 years, between the Burmese

---

<sup>(a)</sup> The term used for GAUDAMA or any priest's eating is, "giving it glory."

<sup>(b)</sup> *S. Nairanjana*

<sup>(c)</sup> *S. Chaitya?*

<sup>(d)</sup> *Sembojeti.*

<sup>(e)</sup> *Sri Dharmasoka.*

<sup>(f)</sup> *Paribboga jeti.*

<sup>(g)</sup> The Burmese letter  $\text{ၵ}$  is often pronounced as *ch*, and is used always for the *ch* in Páli or foreign words, but the usual sound given to it is more like a hard *s* pronounced with the tongue pressed against the roof of the mouth.

sacred year 162, and 186 or B. C. 382 and 358. He is also described as having been of the race of *Mauriya*, as having killed his predecessor DHANANANDA, the last of the eight *Nandas*, at the instigation of a Bramin named ZANEKKA, (a) and as having been consecrated king of the whole earth, implying that he possessed extensive power. The Burmese history also applies to this king TSANDA-GOUTTA, and not to NANDA, as Colonel WILFORD gives it from Sanscrit authors, the tale of his lifeless corpse having been re-animated and actuated by his presence—but by the soul of a *Bheeloo* or monster, and not by that of a magician. The son of this king, who was called BHEINDOO-THARA (b), from the circumstance, it is said, of his body being covered with some eruption, and who appears to be the same as the VARISARA of Sanscrit authors, killed the *Bheeloo* by a device, and ascended the throne in the Burmese sacred era 186 or B. C. 358. He reigned 28 years and was succeeded by his son THERRI DHAMMA THAUKA, who is also styled ATHAUKA, in the Burmese sacred year 214 or B. C. 330. The Burmese always use a soft *th* for *s*, and hence ATHAUKA is evidently the same as ASOCA-VERDHANA and ASOCA in Sir WM. JONES'S and Colonel WILFORD'S lists of the kings (c) of *Magadha*. This prince appears to have restored or established more extensively the religion of GAUDAMA, and hence the Brahmins of India have probably destroyed all accounts of his government; but the Burmese possess copious details, and the latter half of the 2d volume of the *Myamma Maha Yazawen-dau-gyee* (d), or large Burmese royal history of kings, is filled with an account of this king's reign. He is described as a *Mauriya* king of *Magadha*, as the grandson of TSANDA-GOUTTA, and as having held his capital at *Patalipout*, which the Burmese consider with Major RENNELL to have stood on the site of the present town of Patna. He is described also, as having been consecrated, or as having received the sacred affusion as king of *Zaboodipa* (e) island, four years after his accession to the throne, in the Burmese sacred year 218 or B. C. 326. It was after such consideration, as this inscription mentions, that he resolved upon building, and he carried his resolution into effect, a monastery and monument to the memory of GAUDAMA BOODH, (f) in 84,000 different parts of his empire; and he selected that number, it is said, because one collection of the precepts of GAUDAMA, called *Dhamma Khanda*, is divided into 84,000

---

(\*) *Chanacya* of Sanscrit authors.

(b) See vols. 2d and 9th of *Asiatic Researches*, Octavo edition.

(c) *Bindusára* or *Bimbasára*.      (d) *Barma mahá Rajawendogri*.      (e) *Jambu dwipa*.  
 (f) *Gautama Buddha*.

sections. One of the 84,000 temples then constructed is supposed by some Burmese to have been this *Páyatha-bhat*, which was re-built and on which this inscription was placed, 1430 years after. There are several temples in Burmah mentioned in the Burmese history as having been re-built by different monarchs, on the ruins of those built by **THEERI DHAMMA THAUKA** <sup>(1)</sup> on this occasion. In the 23d year of this king's reign, in the Burmese sacred era 237 or B. C. 307, the third and last rehearsal of the communications of **GAUDAMA** took place at *Pátalipout* <sup>(2)</sup> under the protection of this sovereign and superintendance of **MAUGGALI POUTTA-TEITHA** <sup>(3)</sup>. The Burmese history has no account of any king of *Magadha* or Central India subsequent to this prince, whose dynasty is supposed to have become extinct with him, as his brother, son and daughter all assumed the priesthood and rejected the throne. The son, prince **MAHEINDA**, <sup>(4)</sup> proceeded to Ceylon and established the Buddhist religion there, and it is curious to observe that according to the native historians of Ceylon, the name of the person who introduced Buddhism into that island is **MIHENDOO** <sup>(5)</sup>. **THEERI DHAMMA THAUKA** reigned forty-three years, between the Burmese years 214 and 255, or B. C. 330 and 289. One Burmese history relates, that in consequence of his having died in a fit of passion, his soul upon his death entered the body of a large serpent, and that his son, prince **MAHEINDA**, having preached to and converted him, he died again and proceeded to the *Nat* country or celestial regions. But the large Burmese history contradicts this statement and asserts, that his Majesty immediately upon his death proceeded to the *Nat* country. It is possible, that this tale was invented by the Brahmins, as they tell a similar one of a king of *Cashmere*, who according to them, was turned into a serpent for having delayed feeding some hungry Brahmins <sup>(6)</sup>;—and at all events, the learned will recollect, that some among the ancients believed, that the *marrow of the back bone* in a wicked man turned into a huge and fierce serpent. Sir **WM. JONES** and Colonel **WILFORD** have shown, that **CHANDRA-GUPTA**, or **TSANDA-GOUTTA** of the Burmese, is the same as the **SANDRA-COPTOS**, with whom **SELEUCUS** entered into alliance, and the learned Colonel has also shewn, that this alliance took place in the year 302 B. C., thirteen years after **CHANDRA-GUPTA** had ascended the throne, and that he reigned twenty-four years, and died 292 years before our <sup>(7)</sup> era. According to the Burmese

---

(1) *Sri Dharma Asoka.*      (2) *Pátaliputra.*      (3) *Mauggaltputra.*      (4) *Mahendra.*

(5) See **M. JOINVILLE's** paper on Singhala or Ceylon in the 7th vol. of the *Asiatic Researches*.

(6) See **Dr. WILSON's** paper on the History of Cashmere, p. 22, vol. 15th of the *Asiatic Researches*.

(7) 9th vol. of the *Asiatic Researches*, octavo edition, p. 96 and 100.



historians, the date TSANDA-GOUTTA is said to have ascended the throne is 382 years before Christ, and the date of his death 358 B. C., being sixty-six or sixty-seven years earlier than the periods fixed by Colonel WILFORD. This is a small error in an Indian date, and it is most probably an error on the part of the Burmese; for we can scarcely suppose that, in the time of SELEUCUS, THEERI DHAMMA THAUKA was known also by the title of his grandfather, as Colonel WILFORD has shown that the names given by old authors to the son and grandson of SANDRA-COPTOS, namely, ALLITROCHATES and SOPHAGESIMUS, apply to VARISARA *alias* MITRA-GUPTA, and ASOCAVARDDHANA *alias* SHIVACASENA<sup>(b)</sup>. THEERI DHAMMA THAUKA then must be the same as the king SOPHAGESIMUS for renewing the alliance with whom ANTIOCHUS the Great went to India; and the date of his ascending the throne must be 264 years before Christ, and not, as the Burmese have it, 330 years. *Theeri* is the same as the Sanscrit *Sri*, excellent—*Dhamma* is law, and religion too—and *Thauka*, which means care and anxiety, is said to have the privative initial particle *a* dropt in composition, but being understood, the word here implies *freedom* from care and anxiety<sup>(c)</sup>. When THEERI DHAMMA THAUKA'S mother was pregnant, she dreamt that she had one foot upon the sun and the other upon the moon, and that she was eating the stars. The dream was interpreted, that her child would bring the whole of *Zaboodipa*<sup>(d)</sup> island, which is equal to the sun and moon in beauty and splendour, under subjection, and that he would kill all his brothers. The latter part of the interpretation proved correct enough, as THEERI DHAMMA THAUKA is described as having killed no less than ninety-eight of his brothers, upon the death of the father, when they disputed the crown with him.

3.—*Zaboodipa* or more properly *Zamboodipa*<sup>(e)</sup>, the island of the *Jambū* or *Eugenia* fruit, is one of the four great islands, the southern one in the Buddhist system of the universe. It is so named from the circumstance of a tree of that species growing on the extreme north end of the island;—it is the same as this our earth, and hence, “king of *Zaboodipa*” means, king of the whole earth.

4.—This is the Buddhist sacred era commencing, according to the Burmese, 544 years before Christ, and our present year 1834 is their 2378th religious year. On the death of GAUDAMA, a king of *Magadhā* named AJĀTA-THAT<sup>(f)</sup>, assisted by one of GAUDAMA'S disciples MAHĀ KATHABA<sup>(g)</sup>, resolved upon establishing a new epoch commenc-

---

(b) P. 286, vol. 5th Asiatic Researches.

(c) *Jambudwipa*.

(e) *Ajātasatru*.

(g) *Mahā Kasyapa*.

ing from the year of that BOODH'S death. The name of this king resembles most that of AJATA-SATRU in Sir WM. JONES'S and Col. WILFORD'S lists of the kings of *Magadha*, but AJATA-SATRU is supposed by the Colonel to have reigned many years later, than what is given in the Burmese history as the date of AJATA-THAT'S reign or about the year 450 B. C. According to the Burmese, the father of AJATA-THAT was PBIM-BHA-THARA <sup>(8)</sup> and his successors in relation were—

His son AJATA-THAT, who reigned until the sacred year, .....	24
His son OODAYA-BHADDHA <sup>(9)</sup> , who reigned until .....	40
His son ANOOROUDDHA <sup>(10)</sup> , .....	0
His son MOUDHA <sup>(11)</sup> , who reigned until .....	48
His son NAGADATHA, <sup>(12)</sup> who reigned until .....	72

Each of the above mentioned five kings killed his father who preceded him ; and the last, NAGADATHA, was deposed by his subjects, who placed on the throne an officer or minister, THOOTHONAGA. This king, whose name resembles so closely SISUNAGA in Sir WM. JONES'S list of the kings of *Magadha*, was succeeded by his son KALATHAUKA <sup>(13)</sup> in the sacred year 90. KALATHAUKA was succeeded in 118 by his son BHADDHA-THENA, <sup>(14)</sup> who is described as having reigned with nine of his brothers during a period of 22 years. The last brother, PREENZA-MÁKÁ, <sup>(15)</sup> was killed in 140 by NANDA, said to have been a chief of robbers, and to have usurped the throne with the title of OUKKHA-THENA <sup>(16)</sup>. He died very shortly after his usurpation, and was succeeded by eight brothers, the last of whom, named DHANA-NANDA <sup>(17)</sup>, was killed, as mentioned in a preceding note, in the sacred year 162, by TSANDA-GOUTTA, the grandfather of THEERI DHAMMA THAUKA.

5.—PENTHAGOO-GYEE, or the great PENTHAGOO, is supposed by the Burmese to have been some follower of the religion of GAUDAMA, probably a priest ; but he is not mentioned any where in their history. At present it is not customary to say of a priest, as in this inscription, *ta youk*, but *ta ba* ; in former times, however, it is said, priests as well as laymen were styled *youk*.

6.—THADO MBN, or king of *Thado*, was the family title of a race of kings whose capital was at *Tagoung*, a city which once existed on the left bank of the *Erawadi* in

<sup>(8)</sup> *Bimbasára.*

<sup>(9)</sup> *Udayabhadra.*

<sup>(10)</sup> *Anurudha.*

<sup>(11)</sup> *Mudra.*

<sup>(12)</sup> *Nágadatta.*

<sup>(13)</sup> *Kálasoka.*

<sup>(14)</sup> *Bhadraséna.*

<sup>(15)</sup> *Pinjamaka.*

<sup>(16)</sup> *Ugrasena.*

<sup>(17)</sup> *Dharmananda.*

north latitude about 24°. The beginning of the third and twenty-second volumes of the large Burmese history contains some notice of these kings, who were of the race said to be descended from the sun, and also of the THAKEE or THAKYA (18) race, like GAUDAMA. An account of the origin of this term SHAKYA, or as the Burmese write and call it THAKYA or THAKEE, is given in the first volume of the Burmese history, and it corresponds a good deal with that translated by M. CSOMA DE KOROS from the Thibet work, and published in the 20th volume of the Journal of the Asiatic Society. According to the Burmese version, a king of *Baranathi* or Benares, named OUKKAKAREET, expels from his capital four of his sons and five daughters, who go and found the city of *Kappilawot* (19), where GAUDAMA was afterwards born; and the four princes, the eldest of whom named OUK-KAMOUKKHA, appoint the eldest sister to take the place of mother, and marry the other four sisters. When the father hears of this proceeding he observes to his courtiers, "my sons have ability indeed (*thakee tau* in Páli) to take care of our lineage;" and thence, all kings of *Pátalipout* were styled of the *Thakes* or *Thakya* race. The first king of *Tagoung*, ABHIRÁJA, came from Central India long before the birth of GAUDAMA, and a list is given in the Burmese History of the sovereigns of *Tagoung*, most of whom are designated THADO. The queen of one of these kings, named THADO-MEN-GYEE, was delivered about the sacred year 40 or B. C. 504, of twin sons, MAHA THAMBAWA (20) and TSOOLA THAMBAWA (21), both of whom were born blind. The father directed them to be put to death but the mother placed them upon a raft with provisions and floated them down the Erawadi. An account is given of their voyage down the river, and the sites of some of the towns now in existence, *Tsa-gain*, *Tsa-len*, *Myedé*, are said to have then received their names. The two princes receive their sight on the passage down, and stop at last off *Prome*, close to the spot where an uncle of their's, who had some time before been led so far from *Tagoung* in pursuit of an immense wild hog, had taken up his residence (1).

The eldest prince, MAHA THAMBAWA, here built a city called *Thare Khetara* in the sacred year 60 or B. C. 484, and established the *Prome* dynasty, which flourished 578 years. Some remains of that city are still to be seen a few miles to the eastward of the present town of *Prome*, and Colonel SYMES, who visited the spot, gives a description of

---

(18) *Shákya*. (19) *Kapilavastu*. (20) *Maha Sambhava*. (21) *Chùla Sambhava*.

(1) There are many places named after this Hog—*Wet-ma-zwot*, or Hog not wet, a place where he crossed the Erawadi without the water reaching his belly;—*Wet-ye-gan*, Hog tank, the *Wattygoon* where our army met with one of the most serious disasters during the late war;—and *Wet-kywon*, Hog island, a spot near *Prome*, where the Hog was at last killed.

it. When *Thare Khettara* was destroyed A. D. 94, one portion of the inhabitants removed and settled at *Pagán*, where another capital was built, and another dynasty of kings established, which flourished 1176 years, and lingered 80 years longer. *Pagán* was destroyed by the Chinese, and 80 years after that event, a chief and descendant of the *Tagoung* race of kings, named THADO-MEN-BYA, conquered the last remains of the *Pagán* dynasty, and founded the city of *Ava* and a new dynasty of kings, about the year of Christ 1364. Hence, the kings of *Ava* to this day consider themselves as descended from the *Tagoung* line of kings, and one of their titles *Ne-dwet-Bhuren*, erroneously translated by us (king of the rising sun), means a king come out of or descended from the sun as the *Tagoung* kings were considered. In the same manner the kings of *Ava* pride themselves upon being of the *Thakya* or *Thakee* race, and the late king MENDARA-GYEE, when he married his eldest son to his eldest daughter referred, according to the 31st volume of the Burmese history, to the established custom among the *Thakee* royal race. The term *Thado* may be derived from *Tha-dau* royal son, although some Burmese consider it to be the same as *Tha-to*, a son in addition. At present, it is conferred as a title on princes and the highest ministers of state. The old Kye Woongyee is a *Thado*. *Tagoung* is described as having been destroyed by the Tartars and Chinese, but there are to this day some remains of an old city said to be visible there.

7.—The Lord of the white Elephant and great king of righteousness, or *Tshen-byoo-thaken tara mengyee*, are common titles of the kings of *Pagan* and *Ava*. In the Burmese years 467 and 468, or A. D. 1105 and 1106, the person who bore these titles was a king of *Pagan* named ALOUNG TSBE THOO, and the latter half of the fourth volume of the large Burmese history contains an account of his reign, and refers particularly in one part, to an old inscription which is said to be still extant at *Ava*, commemorating some charitable gifts made by this king to a temple called *Shwe Mouthau*, in which inscription he is styled “Lord of thirty-six white Elephants.” He is also described in the Burmese history, as having reigned for the long space of 75 years, between the Burmese years 455 and 530 or A. D. 1093 and 1168; as having exercised dominion over Arracan, Bassein and Tinnasserim as well as over *Ava*, *Pagan* and *Prome*; and as having travelled more than is usual with Burmese kings,—having visited China overland and Acheen and Ceylon (\*). On the day of his birth, the large honorary drum or *gong*, which agreeably

---

(\*) This king also visited on shipboard, but by what route does not appear, the *Jamboe* tree on the northern end of this island—our north pole!

to a custom that still prevails at Ava, was hanging within the palace, emitted a sound of itself without being struck. This phenomenon was considered as prognosticating the infant's future power and glory, and hence he was called TSEE SHOO, the first word being the name of this kind of drum, and the last an imitation of the sound heard on the occasion. In process of time TSEE-SHOO was changed into TSEE-THOO. ALOUNG is a name of far more importance. It means the rudiments of a Boodh, or an Embryo Boodh, and is applied to a being who is hereafter to become a Boodh. GAUDAMA was so called during millions of years and during his 550 different states of existence, whilst he was completing the measure of good works, which was to perfect him into a Boodh, agreeably to a prophetic annunciation that he had received from the Boodh DIPENGARA<sup>(1)</sup>. This title was given to ALOUNG-TSEE-THOO in the same manner as it was afterwards given to ALOUNG-PHRA (ALOMPRA), by his subjects of their own accord, as a mark of their profound veneration and respect, believing, as they did, that these kings were not common mortals, but beings destined in some future state of existence to become Boodhs. The genealogy of ALOUNG-PHRA, after he had become king, was very carefully traced up to this ALOUNG-TSEE-THOO, and through him to ABHIRAJA, the first king of *Tagoung*. The Burmese history relates the fact of this king of Pagan, ALOUNG-TSEE-THOO, having sent an army to invade Arracan, and place on the throne of that kingdom, a prince named LET-YA-NAN, regarding whom mention will be made in a succeeding note.

8.—THEERI DHAMMA PADA RAJA GOONA<sup>(22)</sup> is supposed to have been a priest who died in Arracan on his route to *Gaya*. His disciple, MAHA KATTABA,<sup>(23)</sup> in consequence of his youth and subordinate rank, is supposed to have been afraid of proceeding on the mission by himself. A priest probably residing in Arracan offered to accompany him, and a reference must have been made to the king at *Pagán*, when, it is imagined,

---

(1) DIPENGARA predicted, that after four *Thenkhye* and 100,000 worlds, GAUDAMA would be perfected into a Boodh. A *Thenkhye* is a numeral, consisting of an unit with 140 cyphers! DIPENGARA was the fourth and GAUDAMA the twentieth of the Boodhs, who have last appeared in this world according to the Burmese. The sculptures and paintings seen in Burmese temples and monasteries of a man lying prostrate at the feet of another, who is addressing him, are intended to represent GAUDAMA as the hermit THOOMEDA<sup>(24)</sup> receiving the prophetic annunciation from DIPENGARA.

(22) *Sri Dharma pada rája Guna.*

(23) *Mahá Kasyapa.*

(24) *Sumita.*

the royal order was sent back, " Let the lord priest WABADATHI fulfil his engagement, and let the chief of the 100,000 *Pyoos* assist and have it done." Some persons at Rangoon fancy, that the form of many of the letters, as well as some idiomatic expressions, proves this inscription to have been put up by a native of Arracan.

9.—PYOO-TA-THEIN-MEN, or chief of 100,000 *Pyoos*, is supposed to have been the prince of *Arracan*, LET-YA-NAN, whom ALOUNG-TSEE-THOO, king of *Pagán*, assisted to recover the throne of his ancestors, and who is said to have established his capital at a place called *Parsein*. ALOUNG-TSEE-THOO sent an army of Talains or Peguers by sea, and one of Burmese by land, but the water force being defeated, the land force retreated without attempting any thing. The king sent the land force a second time, and it then succeeded in conquering and killing THENKHYA'S grandson, MOUNG BADI, the king of *Arracan* at the time, and establishing LET-YA-NAN on the throne. This last mentioned prince was the grandson of a king of Arracan, named MEN BHEELOO, who was killed by an Arracanese noble, THENK-HAYA, who usurped the throne under the title of WAROUNG-NGHET-TSARE. The son of the deceased king of Arracan, named MEN-YE-BHÁ-YÁ, took refuge with ALOUNG-TSEE-THOO'S predecessor and grandfather, THEE-THAIN-SHEN-KYAN-ZEET-THA, who reigned at *Pagán* between the Burmese years 426 and 455, or A. D. 1064 and 1093, but who took no measures for establishing the young Arracanese prince on his father's throne. ALOUNG-TSEE-THOO was induced, as above described, to assist this prince's son and the grandson of the murdered king of Arracan. The Burmese history observes, that some difference exists among the historians of Pagan and Ava as to the exact date when LET-YA-NAN was placed on the throne of Arracan, and refers to a copy of the Arracan history in Arracanese, in which mention is made that this aid was given to LET-YA-NAN after the year 480, or A. D. 1118. It quotes also some verses written in Arracanese, in honor of the sister and wife of LET-YA-NAN, wherein it is distinctly stated that ALOUNG-TSEE-THOO had established LET-YA-NAN on the throne of Arracan with 100,000 Talains and 100,000 *Pyoos*.

When Prome was destroyed, the inhabitants separated themselves into three divisions, part of one of which styled *Pyoo*, sixteen years afterwards, established themselves at *Pagan* and founded the *Pagan* empire. Hence, the people of *Pagan* were often called *Pyoo*, and whilst the Kings of *Ava* pride themselves as being descended from the *Tagoung* race, the Burmese commonalty to this day consider themselves as descended from the *Pyoo* race.

The figures in the two dates 467 and 468, are not very distinct in the inscription.\* The six also in the first and the eight in the last date are not quite clear. If the learned Burmese at *Rangoon* are correct in their reading of the figures, considerable doubt will still exist, how far they are right in considering PYOO-TA-THEIN-MEIN to be the King of *Arracan*, LET-YA-NAN, who they assert, although it is not mentioned in their large history, was styled chief of 100,000 *Pyoos*, because he was born at *Pagan* and had been established on the throne by 100,000 *Pyoos*. The *Arracan* history, as before quoted, states that LET-YA-NAN was assisted by ALOUNG-TSRE-THOO, after the year 480, that is, at least twelve years after the date of this inscription, in which this name, PYOO-TA-THEIN-MEN occurs. It is more probable then, that this title was given to the chief or general of some *Pagan* army on the frontiers of *Arracan*, and it appears that the first army sent against that country by ALOUNG-TSRE-THOO was forced to retreat.

On referring to the chronological table of the kings of *Arracan* given in Mr. PATON'S Historical and Statistical Sketch of *Arracan* published in the 16th volume of the *Asiatic Researches*, it will be seen, that there are several names similar to those mentioned in the Burmese history. MANICK PHALONG may be the same as the Burmese MEN BHBELOO; SAMKYANG as their THEA KHAYA; MANIK ZADI as MEN BADI; and LEYYA as LET-YA-NAN. This last king of *Arracan* is described in Mr. PATON'S list, as having reigned between the *Mug*, which are the same as the Burmese years 498 and 500, or A. D. 1138 and 1140; and as those dates will be 31 and 32 years subsequent to the dates given in this inscription, here is another ground for doubting the accuracy of the Burmese at *Rangoon*, in considering PYOO-TA-THEIN-MEN to be LET-YA-NAN. The account given by Mr. PATON of the deposition of MANICK PHALONG, by his own Minister SAN KYANG; of his son's taking refuge with the king of *Ava*; and of an army from the king of *Ava* invading *Arracan*, killing the king at the time, MANIK ZADI, SANKAYANG'S grandson, and placing on the throne MANICK PHALONG'S grandson, LEYYA, corresponds very closely with the account given in the Burmese history.

The 32nd volume of the large Burmese History enumerates a list of the kings of *Arracan* from the earliest times down to the date of the Burmese conquest in 1784. This

---

\* The four is made more like a six of the present style of writing—but Burmese scholars inform me, that this numeral four was formerly often written as in this inscription. If we take the two dates to be 667 and 668, the inscription cannot refer to any of the kings of *Pagan*, as that capital was destroyed by the Chinese in the Burman year 646, A. D. 1284.

list differs from that given by Mr. PATON, and many of the names cannot be made to agree. A circumstance owing probably as much to the careless and inaccurate manner in which Burmese and Arracanese copyists transcribe names, as to the difference between the two languages.

10.—PYOO-THAKEN-NGE, or little PYOO-THAKEN, is supposed to have been a priest, and some imagine that it was a name given to the disciple THEERI KATHABA, who had come from *Pagan* as a subordinate in the mission from the king.

11.—*Pya-tho* is the Burmese month, which usually falls partly in our December and partly in January.

12.—This is the Burmese vulgar era, styled by them *Kauza-thakkareet*. The epoch was established in the year of Christ 638, by a king of *Pagan* named POUPPA-TSAU-RAHAN. The calendar had been once before altered by THOO-MOUN-DAREE, a king of *Prome*, in the year of Christ 78, or 622 years after GAUDAMA'S death. It is remarkable, that the Siamese vulgar era, called by them *Chooli Sakarat*, was established in the same year of Christ 638 as the Burmese; and by a king of their own named PHAYA KREK MIBOON, and PHAYA CHOO LI CHAKKA-P,HAT.

13.—This month falls, usually, partly in our October and partly in November.

14.—The present Burmese year is 1196, and if this inscription be considered as having been put up in the year 468 or A. D. 1106, it will now be 728 years old.

15.—Flags made of cloth and paper, of round cylindrical and of flat forms, curiously cut and adorned, and often having prayers and requests written upon them, are presented to temples, and hung up near them and near monasteries as ornaments.

16.—Plates full of boiled rice, with fruit and fish, are laid before temples and images of GAUDAMA, as religious offerings, and this food is afterwards eaten by the pagoda slaves, or by dogs and birds. Lights are also offered and placed as ornaments. They are intended to illuminate the good works of a Buddhist. The word joined to lights in the inscription is read by some Burmese as "a thousand," a number often said to be offered, and by others as "set up," a common expression applied to lights.

17.—The sense here is not very clear in the original, whether these twenty-one young persons composed the *suite* of the mission, or were purchased at *Gaya* and allotted as slaves to the temple, agreeably to the custom in *Burma*, in order to reside constantly near the building, to take charge of it and keep it clean and in order. The Burmese vakeels take the latter sense, and assume that the *Jogees*, who are now at *Buddha Gaya*, are lineally descended from the young men placed in A. D. 1106 to take care of the edifice then



rebuilt. The vakeels also read the number in the inscription as twelve and not twenty-one.

18.—*Padetha* is a tree said to exist in the *Nat* mansion, and in the northern of the four islands forming the Burmese world. It is said to bear clothes and every other article of necessary use, as well as fruits and flowers, and imitations of this tree are made by the Burmese with bamboos having flowers; cups, umbrellas, cloths, &c., hanging to the branches, and presented to temples and monasteries. These trees usually form a part of religious ceremonies in *Ava*, and for a further account of them reference may be made to DR. BUCHANAN'S paper in the 6th volume of the *Asiatic Researches*.

19.—It is a very common custom with the kings of *Ava* to have themselves weighed in gold or silver, and to apply the amount to some religious purpose. The "our" in the inscription is supposed to mean the king ALOUNG-TSEE-THOO, the chief of the 100,000 *Pyoos*, and the priest WARADATHI. The weight in silver of the bodies of these three personages could not have amounted to so considerable a sum as one might at first imagine, for allowing that their average weight was 11 stone 462 lbs. avoirdupois or 561 lbs. imperial troy weight, the whole would not have exceeded 127½ viss of Burmese *dain* silver, or about sicca rupees 16,507. In the year 1774, the whole of the great *Dagon* pagoda at *Rangoon* was gilded with gold of the bodily weight of the then king of *Ava*, TSHEN-BYOO-YEN. The weight of his majesty on that occasion is stated in the 30th volume of the large Burmese History to have amounted to 47 viss and 37 ticals, that is, about 12 stone 3 lbs., and in sicca rupees the value would be about 94,080. This pagoda is now being again gilded, and the sum collected for the purpose from the inhabitants of the country is said to be equivalent to a lac of rupees.

20.—*Neibban* is the Burmese heaven—literally, emancipation from the round of existence to which all animal life is supposed to be doomed, until liberated by good works and placed in a state of quietude like that of annihilation.

21.—*Rahandas*, or as usually pronounced *Yahandas*, are inspired apostles of BOODH, possessing miraculous powers, such as, being able to sit upon water without sinking, to drive through the earth, &c. It was only five or six years ago that a Burmese priest pretended to be a *Yahanda*. He was summoned to *Ava* and treated with great respect, until he was prevailed upon to give a proof of his holy character, by performing the miracle of sitting upon water. He was fool enough to try to perform this feat, and of course soon sunk down. The king ordered

the other priests to remove his sacerdotal garments and drive him out of their community.

22.—ARIMADEYA is to be the 5th *Boodh* in the present system. He is to appear in this world hereafter. No oath is considered by a Burmese with more awe and solemnity, than to make him declare that in the event of his failing in truth, may he never see the BOODH ARIMADEYA.

---

*Extracts from the Journals of the Burmese Vukeels on the subject of the foregoing Inscription.*

Since writing the above, I have obtained a copy of the report which the Burmese vukeels submitted to the king of *Ava* of their visit to *Buddha Gaya*, and I annex a translation of this curious document, together with a copy of a picture, representing the *peepul* tree and surrounding scenery at *Buddha Gaya*, made by a Burmese painter in the suite of the vukeels and presented to the king of *Ava*. Having also obtained a copy of a journal of the late Burmese mission kept by the junior envoy, I add a translation of the passage containing his account of this visit to *Buddha Gaya*.

---

*Translation of a Letter addressed to the King of Ava by the Burmese Vukeels, from Calcutta, in March, 1833.*

“Your slaves MEN-GYEE MAHA TSEE THOO, commissioner, and MENTHANANDA-GYAU-DEN, secretary, making obeisance from under your excellent royal feet, bear your Majesty’s orders upon their heads (meaning most humbly and respectfully petition).

Having made circuit beyond Hindoostan to the extremity of the English dominions, to the city of Furrukhabad at the head of the Ganges

river, and to the city of Agra, at the head of the Jumna river, and having executed your Majesty's service unhesitatingly, devotedly and assiduously, we believed that to bear in mind respectfully our gratitude and obligations to your Majesty, and to fulfil your Majesty's religious duties (literally duty relating to future states of existence), would be a better proceeding. Accordingly, on our return from Agra, finding when we arrived at Patna that the *Maha Baudhi* or excellent *Boodh's* tree at *Buddha Gaya* (the *peepul* tree or *ficus religiosa*, under which GAUDAMA is supposed to have become perfected into a *boodh*) was only three days journey distant, we proceeded thither, and after worshipping and making various offerings in the name of our two sovereigns (king and queen), and prince and princess, consisting of gold and silver *padetha* trees, gilded and silvered candles, common wax candles, other lights in a *tazoung* (a portable pyramidical structure), a gilded umbrella and *thengan* (priest's upper garment), gold and silver *pouk pouk* (imitations of parched grain), and *tagwon*, *koukka*, and *moolbwa* (flags and streamers of various forms), *myooda* (pots with a long neck and open mouth), cold water, rice and other food, together with a hundred rupees in cash, we prayed that your Majesty's glory may be great—that your Majesty's age may exceed 100 years, and that every wish of your Majesty may be gratified and every service accomplished. The merit attending all these acts of charity and worship we humbly present to your Majesty.\*

After making these offerings to BOODH's excellent tree and worshipping it, your Majesty's slave, MENGYEE MAHA-TSEE-THOO, repeated the whole of the *Thamanta* (†) and *Yatanathout* prayers, and, agreeably to their tenor,

---

(\*) According to the *Buddhist* religion, a person may divide with others the merit attending good works performed by him—and thus allow others to share in the future reward. But the loyalty of the Burmese vukeels induced them to tender the whole merit and reward to their sovereign.

(†) These are two long prayers used as a preventive of evil. *Thamanta* meaning "the surrounding," is the first word of one of them.

having summoned all the *Nats* in the ten millions and hundred thousand worlds, (through which the authority of a BOODH is said to extend,) made a solemn appeal in the following eight terms :—BOODH is truly excellent in the three worlds (of *Byamhas*, *Nats* and *Men*). His precepts are excellent. His disciples are excellent. (I) trust in BOODH. (I) trust in his precepts. (I) trust in his disciples. (I) have always worshipped the three objects of adoration (BOODH, his precepts, and his disciples), as well as kept the five commandments (not to kill, steal, commit adultery, tell lies, or use intoxicating substances). (I) have always been grateful to my royal master. Proposing then to invite a piece from the western branch of BOODH's excellent tree, to proceed to the Burmese kingdom, to the spot where religion shines and where the protector of religion dwells, your Majesty's slave, MENG-YEE MAHA-TSEE-THOO, walked round the tree from right to left and poured out some rose water, when owing to the great virtues of your Majesty, worthy to be styled protector of religion, your slave beheld within the brick platform of five gradations, which surround the body of the tree as high up as the point where the branches strike off, what was wonderful, never having happened before, most curious and most excellent, and what contradicts the common saying, that a small *peepul* tree does not grow under a large one :—it was a BOODH's adorable tree, of the size of a Chinese needle with only four leaves, and evidently produced by and of the same constituent part as (the large) BOODH's excellent tree. Delighted with joy, your Majesty's slave repeated his solemn appeal, and carefully gathered this plant. It is growing in (your slave's) possession, but in consequence of the stem and leaves being very delicate and tender, it cannot now be forwarded to your Majesty.<sup>(c)</sup>

---

(<sup>c</sup>) Appeals of this kind often making a future good or evil depend on a certain specific condition, are very common—and the truth and virtue of the appellant are considered to be proved, if any remarkable or unusual circumstance occurs, or if any event, which he desires,

The guardians of BOODH's tree also delivered for the purpose of being worshipped by your Majesty, some boughs leaves and fruit from the western branch of the tree, and these are now in the charge of your Majesty's slaves, MENGYEE MAHA-TSEE-THOO and MEN CHA-NANDA-GYAU-DEN, secretary. The chief of the guardians of the tree, *Muhunt Jogee* informed us, that in former times the dominion of the Burmese kings extended to this tree; and that the *Jogees* are the proper descendants of Burmese; and requesting to be allowed to write and solicit your Majesty to become the protector of BOODH's excellent tree, he delivered a letter for your Majesty written with ink in the *Devanagari* character, which (your slaves) now forward.

The good and excellent *Nats* directing us, the captain (Captain G. BURNEY) and your Majesty's slaves discovered that that spot was formerly a part of the Burmese kingdom, as the chief *Muhunt Jogee* had stated, and your slaves submit a copy of an inscription in stone in the Burmese character, together with its meaning. The captain also copied this inscription, and on showing it to the governor general, he observed it is true the Burmese have cut and put up this, but you must ascertain from MENGYEE MAHA-TSEE-THOO and MEN CHA-NANDA-GYAN-DEN, the secretary, at what period and in what king's reign this was done. When the captain came to ask your Majesty's slaves, they stated that as the date mentioned in the inscription is 467, it was done in the reign of ALOUNG-TSEE-THOO, king of *Pagan*:—that in that king's reign the city of *Parein* in *Arracan* was built by 100,000 *Talains* and 100,000 *Pyoos*;—that that king possessed from *Arracan* to *Delhi*;—that he held *Arracan* also;—and that in consequence of his having such possession, it was said in the *Arracan* song—

<i>Loung-tsee-thoo-khain,</i>	under orders of king ALOUNG-TSEE-THOO,
<i>Ayoo-thain-rwe,</i>	who extended his views,—
<i>Talain-ta-thein,</i>	100,000 <i>Talains</i>
<i>Pyoo-ta-thein-nhen,</i>	with 100,000 <i>Pyoos</i> —
<i>Twet-gyein-kha-gyein,</i>	at the proper time
<i>Pyikka-dein-lyouk,</i>	corresponding to astrological calculations,
<i>Parein-myo-theet,</i>	the new city of <i>Parein</i>
<i>Tee-cha-lect-thee,</i>	did duly build.

---

happens to take place. In the present case, the Burmese envoy evidently considered the little *peepal* tree as a miraculous answer to his appeal, proving his own truth and virtue, although he pretends to owe such an extraordinary incident to the great virtues of his royal master.

Your Majesty's slaves thus showed by producing and reciting an apposite quotation, that *Arracan* and all the *Kula* countries had formed a part of the dominions of the Burmese kings.\*

On this occasion, agreeably to the *Páli* text, "he who takes care of religion, religion takes care of him," and agreeably to the phrase, "by fulfilling religious duties secular duties also will be fulfilled, the time having arrived when a reward for your Majesty's having attended so much to charity, religious duties and all the virtues, was to appear, "good works bring reward in the present world" (a *Páli* text), all the good and excellent *Nats* duly directing your Majesty's slaves, a stone inscription and ancient record, which is most curious and which had not been found before during the reigns of so many kings, was brought to light.

The meaning of the inscription is—that near the temple of MAHA BAUDHI PARIBAUGA, your Majesty's ancestor THEERI DHAMMA-THAUKA had first built the monastery of *Tshwon-tsa* (eating charitable food):—that afterwards the priest, the great PENTHAGOO, had repaired it:—that afterwards king THADO had repaired it:—and that afterwards the master of the White Elephant and lord of righteousness repaired it. During the whole line of the fifty-five kings of *Pagan*, the race of THADO, kings of *Tagoung*, was not extinct; and accordingly, it was a THADO-MEN-BYA, son of a THADO-TSHEN-T,HEEN, who founded the city of *Ava*. The king THADO mentioned in the inscription (your slaves) take to be the king reigning in *Tagoung* at that time. With respect to the term "master of the White Elephant and lord of righteousness," referring to the date 467, (your slaves) suppose king ALOUNG-TSEE-THOO to have been so called. That king was born in the year 440, and he ascended the throne in 455. Deducting 455 from the date mentioned in the inscription 467, gives the 12th year of king ALOUNG-TSEE-

---

\* It is difficult to understand how the vukeels made out that *all* the *Kula* countries were once a part of the Burmese dominions, unless they gave to the words in the second line of the *Arracan* song a very extended meaning.

THOO's reign, in which he deputed the teacher THEERI-DHAMMA-RAJA-GOOROO to repair (the building). That teacher having died before (the work) was finished, and his disciple, THEERI-KATHABA, not going on to complete it, WARADAT-THEE-THAKHEN engaged to do so, and (your slaves) suppose that orders were sent to PYOO-TATHEIN chief, who had built the city of *Parcin*, to send WARADAT-THEE to perform this service. With respect to the twelve young men then presented for the purpose of attending to the duty of burning lights and making offerings of food, as mentioned in the inscription, (your slaves) consider the descendants of these men who were presented as guardians (of the edifice) to have come down uninterruptedly to the present *Muhunt Jogeas*.

Near BOODH's excellent tree there are also many images of GAUDAMA, which have entirely the form and countenance of Burmese. The captain came and asked, if the king called THEERI-DHAMMA-THAUKA was of the Burmese race, and your Majesty's slaves answered, that that king was of the *Thakee* royal race, and that the Burmese kings are of the same race.

Owing to your Majesty's exalted virtues, the large image of GAUDAMA,\* worthy of being invited (to *Ava*), and worshipped by your Majesty, has been obtained; and together with BOODH's excellent tree and the branches, leaves and fruit (of the large tree), your Majesty's slaves will bring in the ensuing month of September, when they return agreeably to the petition which they have submitted, a picture of BOODH's tree and the seven places surrounding it, and a map and description of the rivers, *Nareenjara*, *Ganges*, *Jumna* and *Anauma*—of the hills, *Wengaba*, *Maura*, *Koodabo*, *Mengaladewee* and *Tharagaudika*, and of the city of *Yazagyo*† and when your slaves deliver all these into your royal hands, the whole will be exactly explained and understood."

---

\* This image was formerly in the Asiatic Society's grounds.

† These five hills are supposed to have encircled the ancient city of *Rājagriha*, which the Burmese call *Yazagyo*.

*Extract from a Journal of the late Burmese Mission to Bengal,  
kept by the Junior Envoy.*

“After stopping three days in the city of *Patna*, Kappitan THEERI YAZA NAURATHA (Captain G. BURNEY’s Burmese title,) came to our boat and said, agreeably to the promise which I formerly made that I would ask the governor general to allow you to go and see BOODH’s excellent tree on your return from Hindostan, I have obtained his permission and you may, if you please, set off three days hence,—on Friday next. We replied, that we should like to go, and palankeens, bullock carts, and tents having been provided, we set off from the ghât at *Patna*, on Friday, the 25th January, 1833.

After travelling five *taings*,<sup>(a)</sup> we came to the little river of *Poonassoonadee*: three *taings* farther, we saw the *Mawrahat-nadee*, and half a *taing* farther, we came to the hill and village of *Animau*, where we halted (for the day.) Resuming our journey, we came in six *taings* to the *Daradh* river and village of *Zakánat*, where we again halted. Departing from *Zakánat* village, we came in four *taings* to the village of *Meggadwonpoo*, near the little river *Zamoonee*, and saw (from thence) six *taings* to the southward, the five mountains which encircle the city of *Yazagyo* (*Rájagriha*.) We halted five *taings* beyond *Meggadwonpoo*, at the village of *Thela*. On the next day, we came in seven *taings* to the city of *Gara-thee* (*Gaya*,) and after travelling three and a half *taings* farther, we arrived at *Bouddha Gara*, (*Buddha Gaya*,) and BOODH’s excellent tree, and put up to the eastward of that tree in a garden on the bank of the *Nareenjara* river. BOODH’s excellent tree is thirty-four *taings* distant to the south-southwest of *Patalipout*<sup>(b)</sup> or *Patna* city.

Of the seven places in which the most excellent GAUDAMA rested, the four following only are now visible, and they were seen by us. The village

---

(<sup>a</sup>) A Burmese *taing* measures nearly two English miles.

(<sup>b</sup>) The ancient name of *Patna* according to the Burmese.



of *Tzyapala* or *Tsheit-kyoung*, goat's grazing ground—*Yatana Zengyan*—*Aneimmettha* hill—and the lake of *Mounzaleinda*. The remaining places—*Lenwon* tree, *Yatanagara* or *Shweain*, golden house, (and *Baudhipallen*, or throne of gold under the *Peepul* tree,) have disappeared and could not be found on enquiry. With respect to the four places now visible, the lake of *Mounzaleinda* is above ten *tas*<sup>(c)</sup> to the south-west of BOODH's tree. *Yatanazengyan* with its temple is seven *tas* to the eastward of the tree. The hill of *Aneimmettha* with its temple lies to the north-north-east of the tree. The *Nareenjara* river is upwards of forty *tas* to the eastward of the tree. The *Kulas* call that river *Nilazala*, (*Nilajan*) and on its eastern bank is the temple, *Tsheit-kyoung-myoung*, in the village of *Tsheittan*, which the *Kulas* now call *Bagaroo-goun*.<sup>(d)</sup>

After seeing and examining every spot and object, we prepared handsome and suitable flowers of pure gold and pure silver, gilded and silvered candles, gilded priest's garments, umbrellas, and flags and streamers, with all of which, together with 1000<sup>(e)</sup> lights, we worshipped and made offerings to BOODH's excellent tree, in the name of the most glorious and excellent sovereign lord (king of *Ava*). The principal guardian of the tree, *Muhuntazee-zangyee*, (*Muhunt Jogee*) took charge of the gold and silver flowers.

This *Muhunt Jogee* told us, that the English chief has given him *twenty-seven* villages contiguous to BOODH's tree, and that he lives on the revenue derivable from the same. He occupies a three-storied brick-house, with all his disciples and subordinate *Jogees*, living in the lower and uppermost portions of it. He dresses himself in gold and silver *Kinkháb*, with gold and silver flowered muslins, and uses a rosary consisting of beads of pure gold of the size of the stone of the *Tshee-byoo* fruit. On asking him how many disciples and followers he had, he said upwards of five hundred, some near him and some at a distance. The subordinate *Jogees* who constantly,

---

(c) A *ta* is a measure of length equal to seven cubits.

(d) See note at the close.

(e) In figures in the original.

throughout the day and night, remain on guard near BOODH's tree, are LWOT-TSAN, KHARAT, YANTEE, HATRA and GOMYEN, which five men are appointed to this duty by the principal *Jogee*.

The circumference of BOODH's tree on a line with the top of the encircling brick platform of five gradations, which forms its throne and is thirty-five cubits high, measured nineteen cubits and ten fingers breadth. The tree rises forty-four cubits above the brick platform. From the top of the tree to the terrace on the ground on the eastern side, may be eighty cubits, or a little more only, apparently, the boughs and small branches, which once grew upwards, have in consequence of the great age of the tree spread out laterally, and this is the reason why the present height of the tree does not correspond with that mentioned in the scriptures. It was fresh and young when GAUDAMA was perfected into a *Boodh*, and some of the boughs and small branches must then have been growing straight upwards, as well as some laterally—hence, we must believe that it was truly said in the scriptures to be a hundred cubits high—After going round and round BOODH's excellent tree, and offering our devotions to it during three days, we gave the guardian of the tree the *Muhunt Jogee* 80 rupees, and a present of 20 rupees to his disciples, and the subordinate *Jogees*, and returned (to *Patna*.)”

---

NOTE.—According to the *Buddhist* scriptures GAUDAMA, after he had become perfected into a *Boodh* under the *Peepul* tree, rested seven days at seven different places in the neighbourhood of that tree. These seven times seven days are called *Thatta Thattaha*, and the seven places *Thatta T,hána*—which are described as follows :

1st. *Baudhi pallan gan, pat,hama t,hána*—Place of the golden throne which had miraculously risen from the ground under the shade of the *Peepul* tree, and upon which GAUDAMA sat immovable seven days.

2d. *Aneimmittha koun, dootiya t,hána*—This was a spot on a rising ground at a short distance from the tree, at which GAUDAMA stood immovable, looking at the golden throne “without winking or blinking,” during seven whole days.

3d. *Yatana zen gyan, tatiya t,hána*—This was another spot near the tree where GAUDAMA walked backwards and forwards in the air during seven days.

4th. *Yatana gara*, or *shwe ain, chadout, ha t, hána*—A golden or gilded house which appeared miraculously near the tree, and in which GAUDAMA remained seven days.

5th. *Izzapala tsheit kyounng nyounng beng, punjama t, hána*—Peepul tree growing on a piece of ground where goats usually grazed, and under which tree GAUDAMA remained seven more days.

6th. *Mounzaleinda ain, tohattama t, hána*—Lake or tank of *Mounzaleinda*, in which dwelt a *Nága* or Dragon, in the coils of whose body GAUDAMA sat seven days, covered by its hood completely from incessant showers of rain.

7th. *Yaza yatana*, or *len lwon beng, thattama t, hána*—A tree called *Len lwon*, under which GAUDAMA lastly sat during seven days, and whilst seated here, two brothers, merchants of a city called *Onkalaba*, near the site of the present town of *Rangoon*, paid their devotions to GAUDAMA and presented him with some bread soaked in honey. He delivered to them in return eight hairs which he plucked out of his head, and when they returned home, they built a temple depositing in it some of these hairs, which temple, but enlarged and improved by different kings, is the present great *Shwe dagoun* temple at *Rangoon*.

BOODH's Peepul tree had originally five large branches—but the southernmost was broken off by king THEERI-DHAMMA-THAUKHA, and sent as a present to a king of Ceylon, called DEWANAN-PEEYA-TEITT, HA,

The above note will elucidate the accompanying copy of a picture, representing BOODH's tree and the temple at *Buddha Gaya*, which was painted by a Burmese painter in the suite of the mission, and presented to the king of *Ava*.

*Rangoon, June, 1834.*

H. BURNEY.

---

## P O S T S C R I P T.

Having ventured, on the authority of RATNA PAULA, a Ceylonese Christian, well versed in the *Páli* and Burmese languages, whom I employed to correct the lithograph of the facsimile, and of the Burmese version, of the inscription received from Colonel BURNEY, to insert or alter such letters as appeared on comparison with the stone, to be wanting or erroneously written in the Burmese transcript, I have thought it incumbent on me to append a list of these corrections, although the greater number are of no importance. The only two indeed which it is material to notice are those marked (E) and (I,) where the change makes a difference of 200 years in the date of the inscription, being read at *Ava* 467 and 468 respectively, whereas RATNA PAULA reads them 667 and 668. I have taken particular care that the facsimile should be correctly copied in these two places, and I confess, that although the first figure of the upper date is a little doubtful from the tail not being carried up so high as in the second, the first 6 of the lower date seems to

me quite plain, and essentially different from the 4, which occurs in the second line of the inscription, (*h.*) In the translation published in the *Journal*, Vol. III. page 214, the latter date was adopted: and I had since imagined that the circumstances of the frequent destruction of the building, and its final completion in the year 1305, A. D. were in some measure borne out by the fact noticed in Colonel TOD'S *Rájasthán*, of frequent expeditions made from *Méwár* in the 13th century "to recover *Gaya* from the infidels." Before venturing however to allude to my own reading in opposition to Colonel BURNEY'S, I referred to the author at *Ava*, remitting him the portion of *facsimile* including the date, for his re-examination. I now subjoin his reply, to which every deference is due; yet it appears to me possible that the Burmese may have a bias in favor of the date which can be best reconciled with their history; in reading 667 they must have conceded the honor of rebuilding the temple, as Colonel BURNEY states, to the King of *Arracan*.—J. P. SEC.

"Your letter of the 16th October reached me yesterday, and I lost no time in showing to the MYAWADEE WOONGYEE (the most intelligent and learned Minister here), to the late Burmese Vukeel MAHA-TSRE-THOO, and to a whole company of Burmese *Savans*, your *facsimile* of the figures in the *Gaya* inscription, which however do not differ in the least from those in the copy we had here before. My friends still insist upon it, that the first figure in both dates is a 4, such as is commonly written in the *stone* character, and not a 6; and referring to another 6 in the inscription, that denoting the day of the week, Friday, they ask me to observe the difference. In the figure 4, the last portion of it does not rise so high or above the line as the same part does in all the three sixes, and the body of the figure is rounder and more upright, and the elbow more marked than in the 6.

I cannot see also how your "collateral evidence from TOD'S *Rájasthán*" is applicable. Both Missions to *Gaya*, that which met with impediments, and that which succeeded in repairing the temple, appear to have taken place during the reign of the same King, TSHEN-BYOO-THAK, HEN-TARA-MEN, and the period between the two Missions could scarcely have been so great as that which elapsed between "the crusades of the *Rájputs* to recover *Gaya* from the Infidels in 1200-1250," and your date 1305. These crusades might have occurred after the temple had been re-built.

"Again, the capital of *Pagán* was destroyed by the Chinese in the Burmese year 646, A. D. 1284, and for several years after this country appears to have been divided into several little principalities—In 667, 668, A. D. 1305 and 1306, a King named THEEHA-THOO, reigned at *Penya*, a town to the south of *Ava*, permitting, as the Burmese Chronicles say, TSAU-NEET, the grandson of TAROUP-PYE-MEN, the King who fled from the Chinese, to reign at *Pagán*. Adopt your reading of the inscription, and we must believe that this King of *Penya*, or (which I think is more probable), some King of *Arracan* sent these Missions to *Gaya*. These Burmese *Savans*, however, insist upon giving the credit of this good deed to ALOUNG-TSRE-THOO, King of *Pagán*."

H. B.

"*Ava*, 8th December, 1835."

*Note of the alterations introduced in Version II. of Plate II, (the Transcript of the Facsimile, Plate I. in the Kyouk-cha, or square stone-letter,) on comparing the Copy received from Ava with the three fresh Facsimiles taken by Mr. Hathorne, from the original stone at Gaya.*

J. P.

The figures denote the commencement of each line in the original :—The letters mark alternations of reading, as follows :—

<i>Ava transcript.</i>	<i>Lithographed transcript.</i>
a.    𑄂 <i>r</i> , altered to	𑄂 <i>ra</i> .
b.    𑄃 <i>ná</i> , . . . . .	𑄃 <i>ná</i> .
c.    𑄄 <i>ni</i> , . . . . .	𑄄 <i>nhui</i> .
d.    𑄅 <i>n</i> , . . . . .	𑄅 <i>n</i> .
e, l, o, p, the letter	𑄆 <i>w</i> , omitted in the Ava transcript.
f.    𑄇 <i>r</i> , altered to	𑄇 <i>y</i> .
g.    𑄈 <i>hi</i> , . . . . .	𑄈 <i>ri</i> .
h.    𑄉, 4, this figure is here correctly used in the Ava text as 4.	
i.    𑄊, <i>m</i> , altered to	𑄊 <i>y</i> .
j, k, n, q, s, t, u, v, w, x, y, z, A, C, D, H, Q, s, U; in all these cases the form 𑄋 is used for the letter <i>r</i> , in lieu of 𑄌, which latter agrees better with the facsimile.	
r. in this the latter form of <i>r</i> ( <i>rya</i> ) is used in the Ava version.	
B.    𑄍 <i>tu</i> (grandson) altered to 𑄍 <i>hu</i> (by):—this may be a fault of the sculptor.	
I. E. 𑄎 (4.)       altered to	𑄎 (6) on the authority of the facsimile.
J. F. 𑄏, <i>y</i> , . . . . .	𑄏 <i>ry</i> ; it does not alter the sense.
G.    𑄐 <i>n</i> , . . . . .	𑄐 <i>ni</i> ,
K.    caret . . . . .	𑄑 <i>lha</i> .
M.    caret . . . . .	𑄒 <i>thiuv</i> (pronounced <i>do</i> .)
L.    . . . . .	
O.    𑄓, 21, . . . . .	𑄓 2 (men); this reading is doubtful.
P.    caret . . . . .	𑄔 <i>k</i> .
R.    𑄕, <i>koa</i> , to, . . . . .	𑄕 <i>mriy</i> , earth—doubtful reading.
T.    𑄖 <i>aym</i> , . . . . .	𑄖; does not alter the sense.

VI.

---

## RESULTS OF AN ENQUIRY

RESPECTING THE

## LAW OF MORTALITY,

FOR

## BRITISH INDIA,

DEDUCED FROM THE REPORTS AND APPENDICES OF THE COMMITTEE APPOINTED BY  
THE BENGAL GOVERNMENT IN 1834, TO CONSIDER THE EXPEDIENCY OF A  
GOVERNMENT LIFE ASSURANCE INSTITUTION;

---

BY CAPTAIN H. B. HENDERSON,

*Asst. Mily. Audr. Genl., Secretary to the Committee.*

---

FROM the enquiries set on foot during the operations of the Committee appointed by Government to enquire into the state of Life Assurance in India, a variety of curious and interesting documents have come to hand, and possibly a greater number of statements tending to elucidate the rate of Mortality of British India, than have been before accumulated. To consolidate or abstract the results of the information thus obtained, it is hoped the following will not be unacceptable.

With respect to the Natives themselves of the vast regions under the British Rule in India, there are few general tabular statements available, and no extensive or sure data in our possession of a nature to exhibit the

general ratio of mortality, compared with that of the population of other parts of the world. A statement lately published in the *Delhi Gazette*, giving the population, births, marriages, and deaths of that city for the past year (1833), throws some light on the subject, but the term is too short to afford a proper view of the state of the case, and the numbers and details not sufficiently precise to give a positive result for other similar places. From this statement, it would appear that the mortality at Delhi, though much greater than that experienced in the northern latitudes of Europe, is somewhat more favorable than that of the Roman States and Ancient Venetian Provinces, being a fraction less than one in twenty-eight souls per annum; the latter being stated at one in twenty-seven. The ratio, however, greatly exceeds that of Europe altogether, which by some recent returns is one in forty-four for the north, and one in thirty-six for the south; for better immediate reference, the Delhi statement, just referred to, is here given as published by the Civil Authorities of that City.

	<i>Males.</i>	<i>Females.</i>	<i>Total.</i>
Adults, .....	39,592	41,526	81,118
Children, .....	20,553	18,189	38,742
<b>Total Population, .....</b>	<b>60,145</b>	<b>59,715</b>	<b>119,860</b>

	<i>Births.</i>	<i>Deaths.</i>	<i>Marriages.</i>
Males, .....	2,002	2,168	601
Females, .....	1,731	2,080	527
<b>Total, .....</b>	<b>3,733</b>	<b>4,248</b>	<b>1,128</b>

<b>DEATHS.</b>	<i>Males.</i>	<i>Females.</i>	<i>Total.</i>
At 1 year and under, .....	604	505	1,109
1 to 2 years, .....	270	276	546
10 years and under, .....	360	303	663
Adults, .....	934	996	1,930
<b>Deaths, .....</b>	<b>2,168</b>	<b>2,080</b>	<b>4,248</b>

From the above it appears that rather more than  $3\frac{1}{2}$  per cent. per annum is the general rate of decrement ; and that more than one-fourth of the deaths occur in the first year of infancy ; which, however, is a more favorable result for that tender period, than London could exhibit 50 years back, when nearly one-third of its native-born population were found to de cease in the first twelve months after birth. More than half of the total deaths at Delhi in 1833 seem to have occurred under 10 years of age : while the excess of mortality in males keeps pace with the observations of other countries : among adults, generally, one dies yearly from a number of forty-two, and one from every sixteen below the age of ten. In some remarks added to the table itself, it is said that a small number from the deaths may be deducted for strangers and foreigners, and a large proportion for the small-pox in Delhi, since the abolition of the Vaccine Institution. The calculation does not include the royal palace, said to contain twenty thousand souls.

Application having been made to Delhi for information regarding any period prior to former years, it was stated in reply that the enquiry had not been instituted for 1833. In future, it is hoped, these bills of mortality will be regularly exhibited.

The native soldiers on the Bengal Establishment are particularly healthy under ordinary circumstances. It has been found by a late enquiry, embracing a period of five years,\* that only one man is reported to have died per annum, out of every one hundred and thirty-one on the actual strength of the army. So injurious, however, is Bengal Proper, to this class of natives, in comparison with the Upper Provinces, that although only one-fourth of the troops exhibited, are stationed in Bengal, the deaths of that fourth are more than a moiety of the whole mortality reported. It cannot be affirmed that this Table affords any criterion

---

\* Vide Table No. 1.



of the decrement of the population at large; the very best periods only of life, (generally speaking from 20 to 45) are received in the statement which gives these results; the Sepoys are healthily employed, well clothed and attended, while many unrecorded deaths occur at their own homes, where, as a last resource, bad cases are allowed to proceed on medical certificate. It would seem by other documents\* that out of about eighteen thousand invalid fighting men, of the Bengal Army pensioned by the State, six hundred and eighty deceased during the year 1831-32, or one out of  $26\frac{1}{2}$ ; while the average duration of the pension enjoyed by this class of men for a period embracing from May 1828 to October 1830, was 7 years  $8\frac{1}{2}$  months, and from May 1831 to the same month in 1832, the duration of pension was only about 5 years  $4\frac{1}{2}$  months.

It is to be regretted we are in possession of so little other information regarding natives. In common circumstances we may presume there is a tolerably uniform rate of mortality in most situations; but, perhaps, in no climate is there less tenaciousness of life in times of pestilence or famine than among the too delicate mass of our native population, and more particularly in Bengal Proper. The vast number that perish under these calamities, or under visitations of Providence, such as the late inundations, would defy all calculation or attempt at tabular exhibition. In the statistics of British India it is still, however, a grand desideratum,—the possession of an accurate census of the large populous cities, with regularly published annual statements of the births, marriages and deaths, and all other information on this important point.

The Committee was able to afford more accurate and extensive information of the rate of mortality of Europeans frequenting this country, and although the ever-fluctuating character of the Calcutta European population, or that of the other seats of Government, left them in uncertainty

---

\* Vide Tables Nos. 2 and 3.

as to the real ratio of decrement in their immediate communities ; yet from the regular constitution of the public covenanted services at large under each Government, there were greater facilities for obtaining scrupulous accuracy in India, in every thing relating to the periods of arrival, the ages, and dates of death, of the Company's Civil and Military Services, than can be found perhaps in any other country or scattered community.

The enquiry may commence with the common soldiery among whom the greatest mortality necessarily shews itself, from their habits, greater exposure, and the absence of much of the comfort and protection enjoyed by the higher classes. But it is scarcely needful to remark here that in the present paper there has been essayed no investigation into the causes of mortality, nor has any enquiry been instituted except into mere results and figured statements, called for to assist the Committee in calculating the correct value and expectation of life under the various circumstances of European residence in India. It would appear from a military work, published in England in 1832, on enlisting, discharging, and the pensioning of soldiers, by Mr. H. MARSHALL, Deputy Inspector General of Army Hospitals His Majesty's Service, that our Inspector General, Dr. BURKE, has stated, that coming to India at the mature age of 24 or 26 is the most favorable to health in the soldier, and we beg to call attention to a statement\* furnished by the latter officer in confirmation of his opinion. By it we learn that in 1824, a Regiment employed in Ava, experienced a ratio of mortality among the young men who went out with the corps, to the extent of 38 per cent., or 1 in every  $2\frac{1}{3}$ , while among the Volunteers from other Regiments, who were considerably older, the mortality was 17 per cent. or 1 in 6. In 1825, (still on service in Ava) it was 305 per cent. or 1 in  $3\frac{1}{3}$  among the former or younger class, and only 6 per cent. or 1 in 16 in the latter or older.

---

\* Vide Table No. 4.

The Committee were favored with a complete report from Dr. BURKE himself, embracing in addition to earlier information, the casualties of the last four years for the whole of His Majesty's Army in Bengal. The rates of mortality generally for that term he makes to be 4.99 per cent. per annum with reference to the mean number of the troops. But he exhibits a curious distinction in the rate of danger at the different stations ; viz.

	<i>Deaths to strength.</i>
Fort William, .....	7.59 per cent.
Berhampore, .....	6.77 „
Chinsurah, .....	6.10 „
Cawnpore, .....	4.55 „
Boglepore, .....	3.95 „
Dinapore, .....	3.84 „
Ghazipore, .....	3.80 „
Kurnaul, .....	3.00 „
Meerut, .....	1.99 „
Agra, .....	1.91 „

With respect to the ages of the deceased, the Inspector General has now given more ample information. During the four years 1826, 27, 28, 29, the ratio of deaths was—

From the age of 18 to 20, .....	16.12
20 to 25, .....	9.35
25 to 30, .....	10.13
30 to 35, .....	6.92
35 to 45, .....	9.54

In the above term were included the extraordinary casualties of the war in Ava and the seige of Bhurtpore. But in the four succeeding years of peace and non-exposure of the troops ; viz. 1830, 31, 32, 33, the ratio grows more regular, and assumes the generally steady progressive

increase of danger with increasing years, the same as in all the other Tables in possession of the Committee of officers and others; viz.

From 18 to 20 years, .....	0.58	per cent.
20 to 22 ,, .....	2.24	} 3.44
22 to 24 ,, .....	4.63	
25 to 30 ,, .....	5.86	
30 to 35 ,, .....	5.22	
35 to 45 ,, .....	6.78	

It should be remarked that from 18 to 20, during these four years, the class above represented, consists of recruits enlisted in India, the sons of soldiers of the regiments.

The whole of Dr. BURKE's Report is very valuable. It enters into the causes of the sickness, the difference of seasons, situations of barracks, &c., and other points which cannot fail to be useful. It was forwarded to the Government, and it is to be regretted it could not be appended to this abstract.

The Committee also received from the Secretary to the Medical Board, Quinquennial Table of the Sickness and Mortality of the whole of the European Troops of the Bengal Army, including not only His Majesty's Troops reported on by the Inspector General—but also the men of the Artillery and Honorable Company's European Regiment.\* The Tables confirm Dr. BURKE's Report.

In ordinary circumstances it would seem that about one dies per annum in every 18½ throughout Bengal, but in Bengal Proper the yearly percentage is nearly 7—or one in about 14, while in the Upper Provinces it is considerably less. At one post,—Agra, the percentage has not been 2, or one in 50 per annum, out of a garrison of one thousand men, a more favorable result than shewn in any Table hitherto prepared in India.

---

\* Vide Table No. 5.

The next Table is that of the Calcutta Burials, European and East Indian, at the Park-street Burial Ground.\* From the impossibility of ascertaining, with the means at the disposal of the Committee, the births and periodical accession of strangers, and the difficulty of separating the classes, it was impracticable to prepare from these data an accurate, or even approximating, expectation of life for the city of Calcutta.

It may be presumed that the accessions chiefly experienced, by arrivals from England, include between the ages of 18 and 25, and that thenceforward until the later ages of retirement and return to the native country, there is not much fluctuation in numbers, except in the yearly uncertain and temporary addition of seamen and commercial visitors. This, of course, applies to the European part of the community; the East Indian inhabitants being throughout more permanent and stationary. Under the foregoing supposition, it will be found from the numbers exhibited in the Table that out of a radix of population of both classes to the extent of near three thousand souls of the age of 20 to 25, about one hundred die annually, or, as the real decrements shew, 3.84 per cent. For the next ten years the annual percentage is 5.49. For the ensuing same term, or from 35 to 45 it is 6.7 per cent. From 45 to 55, it is 6.18, while from 55 to 65, (though this term is little to be relied on from the frequent secession of persons retiring to England) the percentage is 8.4. Out of four thousand seven hundred and thirteen burials altogether recorded in 20 years, two hundred and seventy-nine are seamen, who died on a visit to the port—swelling the ratio of decrement, it may be supposed, at the middle ages. It is to be regretted that this Table could not be rendered available for any useful purpose to the Committee: all that could be gathered from it was a picture of Indian mortality, probably in its concentrated, worst, and most appalling character.

---

\* Vide Table No. 6.

It might be supposed that the experience of the late Life Assurance Institutions would have afforded some data for guidance, and have exhibited a fair estimate of the ratio of decrement, among the insuring classes at least; but a little consideration and advertence to the facts before us would explain the difficulty and danger of relying upon the results of the different offices. The insured were chiefly, or a large portion of them, debtors in the services; men, it may be supposed, improvident in their life and habits; a few were adventurers, or others embarked in speculations, either necessitated unwillingly to incur the expence of a Life Assurance, or, as the figured Tables would sometimes lead to the suspicion, urged into the Society by the apprehension of approaching death. Thus, in the Fifth Laudable Society existing from 1822 to 1827,\* there were one hundred and eighty-seven lapses out of one thousand three hundred and ninety lives; no very considerable mortality it would appear at first sight, as it ranges under 3 per cent. per annum,—but on a closer inspection of the Table it will be seen that seventy-five of the one hundred and eighty-seven deaths occurred in the two years immediately succeeding the Assurance, while the remainder of the lapses, one hundred and twelve in number, are traced to have lingered through ten years from the period of entrance into the Laudables. Such a misproportion of early lapses must have arisen from other cause than mere accident.

The Sixth Laudable Table† in the possession of the Committee, gives only the total number of lives and lapses without classing them by years of entrance or decrement; the former were nine hundred and ninety-six in number, and the deaths one hundred and eighty, or 3.6 per cent. per annum—the common average; but by apportioning the presumed periods of lapses among the five years of the Laudable, the more correct yearly per centage would be exhibited at 3.89.

---

\* Vide Table No. 7.

† Vide Table No. 8.

The Oriental has existed for a longer term, and has incurred engagements up to 1833, on so many as one thousand seven hundred and eighty-one lives ; out of which, during twelve years, it suffered to the extent of three hundred and seventy-three lapses. But unless, as will be understood by the more accurate and certain Tables to be hereafter referred to, there have been some extensive frauds at times practised on the Society, it is difficult to account for the very heavy rate of mortality it has experienced. It insured on an average seven hundred and eight lives yearly, losing of these with more or less regularity, more than thirty-one persons in the year, or an actual percentage of 4.39. Its greatest percentage of lapses during one year was 6.89, and its least 2.78. We believe here also some of the heaviest lapses occurred in certain cases shortly after the parties had effected insurance.

Although the Committee were unable to avail themselves of the experience of the Calcutta Life Insurance Offices to form a true estimate of the mortality, it may be remarked that the deaths exhibited by them nevertheless wonderfully bear out the fact shewn in all the general Tables prepared from the Honorable Company's different services of the *regularly progressive ratio of danger* (with a trifling exception only in some of the Tables,) *from increasing years and prolonged residence in India*. The ratio in the Army is generally under 3 per cent. for the first years of exposure, and increases to about  $3\frac{1}{2}$  per cent. at 30 : 4 per cent. at 40 : more than  $4\frac{1}{4}$  at 50, and considerably higher at the next decennial period, while shortly after this time of life the longevity of the surviving Anglo-Indians almost keeps pace with the Northampton and other Tables, prepared during the last century in Europe. In the Civil Service the percentage of mortality for the last forty years has been somewhat under 2 per cent. for the first twenty years of residence in India ; a result far more favorable than that of the other services. After the age of 40, the ratio of decrement would appear to keep pace with that of the Army.

At Bombay a Table\* has been received from England, prepared by an eminent Actuary on data furnished from that presidency, which would have been valuable, but that throughout the document the Actuary, in the absence of more correct data, has erroneously assumed, that the probability of living any one year up to the age of 58 is correctly expressed by the fraction  $\frac{2.6}{2.7}$ ; or in other words, that from the age of 18 to 58, one person uniformly and regularly dies per annum from every twenty-seven members of the service. This error, which it appears the Actuary had no means of rectifying, has vitiated the Table and calculations throughout, as it is at variance with the positive fact of the increasing danger of every five or ten years' residence in India. The progressive ratio of age holds good here as in Europe, with an increased impetus from the effect of climate. The result of this error has made the expectation of life in the Bombay Table nearly 20 per cent. too favourable for all ages above 30 or 35, diminishing the probable value of life for all ages below it. The fraction  $\frac{2.6}{2.7}$  it is believed may accurately represent the average annual decrement at Bombay for the entire service, but it varies necessarily with the age and rank of the individual, much in the same manner we presume as has been actually experienced in the last twenty years in the Bengal Army; where 2.34 per cent. has been the ratio of yearly mortality for Ensigns, 2.75 for Lieutenants, 3.45 for Captains, 4.10 for Majors, 4.84 for Lieutenant-Colonels and 5.94 for Colonels. We may assume the general ages of the Ensigns to have been under 22, the Lieutenants under 33, the Captains and Majors 45, the Lieutenant-Colonels 55, &c.

In the last twenty years (as recently ascertained†) there have died one thousand one hundred and eighty-four Officers of the Bengal Army, or 59.2 per annum, out of an average number of one thousand eight hundred

---

\* Vide Table No. 10.

† Vide Table No. 11.



and ninety-seven persons, or about 3.12 per cent; the mean ages of the deceased were as follows :—

81 Colonels, deceased, mean age,.....	61
97 Lieut.-Cols. ditto, ditto,.....	51
78 Majors, ditto, ditto,.....	40
277 Captains, ditto, ditto,.....	36
651 Subalterns, the mean age not ascertained, but it ranged from 18 to 33.	

It may be as well here to exhibit in a simple comparative Table the difference of the rate of mortality at the three Presidencies, Bengal being clearly less inimical to the health of the European than either Madras or Bombay.

*Comparative annual percentage of Mortality of the Officers of the three Armies of Bengal, Madras and Bombay.\**

PRESIDENCY.	Colonels.	Lieut.-Colonels.	Majors.	Captains.	Lieutenants.	Cornets and Ensigns.	Surgeons.	Asiat. Surgeons.	Total or General Percentage.	GENERAL AVERAGE.
Bengal, ....	5.94	4.84	4.10	3.45	2.75	2.34	—	—	3.12	} 3.85
Madras, ....	5.40	6.11	5.42	5.02	4.17	3.80	4.68	4.31	4.49	
Bombay, ..	5.74	5.45	3.77	3.78	3.96	3.15	4.08	4.21	3.94	

The rate of mortality in the Bengal Pilot Service† has been accurately registered for the past thirty years. Its numbers are not sufficient for any general Table, as the annual effective strength of the Department has averaged only about one hundred and forty individuals. Out of these

\* Vide Tables Nos. 11, 12 and 13.

† Vide Table No 14.

have demised 3.36 per cent, while as many as 31 more, (or 0.73 per cent) have been drowned ; this mode of death having occasioned nearly one-sixth of the entire mortality. On the examination of the Tables of the Pilot Establishment which have been compiled in the Master Attendant's Office, under orders of the Marine Board, several curious circumstances have come to view. Presuming them to be correct, we find their rate of decrement, generally speaking, does not exceed that of the Officers of the Army, but the periods of service and the ages of the deceased are much less than those of the Europeans elsewhere exhibited. Thus while the Branch Pilots or seniors whose time of life corresponds with that of Field Officers, have demised at the percentage of 4.46 per annum, the extreme age of the oldest has been 47 only, the mean age being 44 of all who died. The oldest Pilot on the list had only served thirty years, the mean of servitude for the whole casualties being only twenty-three years. Thirty-two Masters have died in thirty years, the percentage being 4.30, their mean age at the time of death being thirty-six, after a mean of service of seventeen years. The deaths in the First Mates (the most exposed class probably) have been heaviest of any, or 5 per cent. : their mean age was 28, and their period of service ten years. The Second Mates deceased only at half that rate, their mean age being 28 also, their service eight years. Among the Volunteers, the casualties by drowning are twenty, while the natural deaths are only fifty, the total percentage per annum being 4.10, the mean age of the deceased of this rank was 22, and their average periods of service three and a half years.

The Committee received separate Returns of the decrements among the Officers of His Majesty's Regiments stationed respectively at Bengal, Madras and Bombay.\* At the first mentioned place the decrements on the whole are found to be 3.37 per cent. per annum ; at Madras 3.55,

---

\* Vide Tables Nos. 15, 16, and 17.

and at Bombay 3.28. These results would seem to keep pace with the deaths in the Company's Army, but there is reason to believe that there are some discrepancies in the Returns of the strength of His Majesty's Officers, and that many are included (such as Officers with Depôts in Europe and others) who are not exposed to an Indian climate, and whose appearance therefore in the Table would tend to vitiate the correct ratio of mortality throughout. In the Table furnished by Dr. BURKE for the last four years, the percentage has been 4.12 per annum, and in Returns originally sent to the Committee by the Adjutant General of His Majesty's Troops,\* the percentage was as high as 5.40 for the last twenty years. In explanation of this apparent excess the Adjutant General has justly observed that King's Regiments come "to India bodily, the Officers being of different ages from 16 to 50," and the twenty years shewn in the Tables being those of peace in Europe, Subalterns "are from 30 to 50 years of age, while in time of war their age would scarcely exceed 25." In explanation also of there being more deaths among His Majesty's Officers than those of the Hon'ble Company, the Adjutant General states the fact of all the Bengal Regiments having been sent to Ava, while few Hon'ble Company's Troops were employed from Bengal. He also observes that Europeans always compose the heads of columns in attacks of fortified places and consequently are the greatest sufferers. The whole of these reasons are sufficient to explain why there should seem a greater ratio of mortality with His Majesty's Regiments, but it is to be remarked, that the casualties in action are much less in either-service than is generally presumed. In Bengal, out of two hundred and eighty-four deaths in His Majesty's Regiments, only fourteen, in those Returns, appear to have been killed in action, or about one in every twenty of those whose deaths are reported ;

---

\* In the Original Returns, out of an average of 261.20 lives yearly exposed to the climate, the decrements were 14.15 per annum. The corrected Returns, it is believed, contain the Depôt Companies and others in Europe.

at Madras out of three hundred and twenty-four deaths, only ten are returned "in action," or one in every thirty-two; and at Bombay, four are reported out of one hundred and thirty-four deaths, or one in thirty-one. There may be some inaccuracy, however, in this point in the Returns.

In the Honorable Company's Bengal Army the deaths in action have been equally or more rare during the last twenty years, thirty-nine only being reported out of one thousand one hundred and eighty-four casualties, or about one in every thirty; in the Madras Army forty-three out of one thousand three hundred and eighty-seven casualties, or one in every thirty-three; and in Bombay eighteen out of eight hundred and fifty casualties, or one in forty-seven. There is very little difference in this respect between the two services in India, with reference to the total strength of each, as will be seen in the following calculation, shewing the very small percentage per annum of Officers who have been killed out of the average yearly strength of Officers of both services at the different presidencies :

#### HIS MAJESTY'S OFFICERS.

	<i>Percentage per annum killed.</i>
Bengal, .....	0.16
Madras, .....	0.11
Bombay, .....	0.09

#### HONORABLE COMPANY'S OFFICERS.

Bengal, .....	0.10
Madras, .....	0.13
Bombay, .....	0.08

The foregoing explanation is necessary to shew that the adoption of the rates of mortality in the Military Service, as data on which to base a general Table, is not materially affected by deaths in action. It is true the

Civil Service are proved to be less exposed to death by one-third than the Army, and particularly in the junior ages. Yet, for the community at large, including all classes, the Army casualties may be taken as a fair and reasonable criterion.

The Committee, it should be mentioned, in preparing their rates of premium for Life Assurance, availed themselves entirely of Mr. CURNIN'S data and calculations. This Table of Mortality it is not deemed right to publish here, as Mr. CURNIN would probably desire to bring it forward under his own illustrations and details of the process of its laborious compilation. His calculations exhibit the accurate results of research and patient enquiry into the periods of service and dates of death of a greater number of well known individuals than it is believed, have ever been exhibited in any extant Table of Mortality. These calculations alone would have been sufficient to guide the Committee safely to fix the rate of premium, but it was thought fit to adduce at one view in the Appendix to the Report, the whole of the general Documents in the separate and previous possession of the Committee. The whole will be found wonderfully to bear out Mr. CURNIN'S calculations when that gentleman may find it convenient to publish them.

A valuable paper by Mr. H. T. PRINSEP, of the Civil Service, which appeared in the Journal of the Asiatic Society for July 1832, has been made use of. It embraces a period of forty-one years. It appears that between 1790 and 1831, there were nine hundred and four Civilians, who safely reached Bengal, so as to be included in the enquiry. From this number two hundred and seventy-five lapsed in forty-one years, or at the average rate of 2.25 per cent. of the lives yearly ascertained to have been exposed to the decrement.

Another document referred to was a Table by Major DE HAVILAND, of the Madras Army, of the numbers, ages, and mortality of the Honorable Company's Officers under Fort Saint George, from 1808 to 1820 inclusive :

it shows the deaths to have been six hundred and forty-seven in that period, at the rate of 3.16 per cent. per annum, or one lapse in thirty-one and a half lives.

A third also referred to is a statement of the Bengal Army, shewing, as the above, the numbers, ages, and deaths at our own Presidency, (compiled several years ago by Mr. G. J. GORDON) from the year 1760. It gives four thousand one hundred and thirty-eight lives, from which number two thousand one hundred and thirty-five deaths are exhibited. These deaths we find by reference to the Table occurred at the rate of about 3.33 per cent. per annum.

It is unnecessary to republish the three Tables just spoken of, as it is believed, they have all elsewhere appeared—but from the information afforded by them—a general Table\* was prepared by the Secretary of the Committee—which is appended for the sake of comparison, with the Committee's final Table now to be brought to the notice of the Society.

Several of the Committee, it seems, had been led to believe that if accurate Tables of the Indian Army could be obtained for the last twenty years *only*, a more favorable picture of the law of mortality for Europeans in British India would be obtained, than that exhibited by Mr. CURNIN; that his data from their very copiousness—the number of names exhibited, and the extent of time gone back into—must have included every variety of Military Servants from the earliest employment of regular Troops by the Company, and the result in consequence might be less favorable than what is at present experienced. Mr. CURNIN's researches—by exhibiting the casualties of the last century—embraced a period of wars, exposure, and ignorance of proper means of protection from the climate, from which the more recent servants of the Company have been generally exempted.

---

\* Vide Table No. 18.

In a word, it was thought desirable to shew the Government, not only that Mr. CURNIN's Tables were perfectly safe, but that a lower rate of premium than that fixed by him might eventually be adopted with confidence—and although the Committee were not prepared, from obvious considerations of caution, to recommend the lower scale in the first instance, still it would be satisfactory for the Government to see upon what sure grounds the State was solicited to proffer its guarantee.

Under these impressions the Adjutants General of the three presidencies were called upon, with the sanction of Government, to furnish correct Returns, with the names and ages of all Officers who had deceased year by year at the different presidencies since the year 1814—together with the strength of the respective Armies for the twenty years exhibited. The information so obtained, it is not deemed requisite to publish here—particularly as the statements were found insufficient without further details; but these last were effectually procured by a form,\* which the Adjutant Generals' Offices were requested to have filled up—and which it may be useful to print with the other Tables, as they will enable any one who enters into these enquiries to prepare Tables from the data thus given after his own mode of calculating; and, as there are various formula for obtaining the expectation of life, to follow that most approved of by himself. From the new form of statements, and on the assumption that every Cadet's age averages eighteen on his first arrival in India,† it was easy to ascertain how many persons of any given age had passed through,—(and what was the number of decrements in,) any given year of exposure to the

---

\* Vide Tables Nos. 19, 20 and 21.

† Mr. CURNIN has established from the result of a reference to one thousand two hundred and six Baptismal Certificates obtained by him, that eighteen years, less a few days, was the mean age of that number of Officers on their reaching India. No general calculation therefore can materially err in assuming the age in question.

climate. Thus Tables, Nos. 22, 23, 24\* were prepared for each presidency respectively.

From these last a general Table was correctly made out; *half* the number of Officers yearly retiring, or otherwise quitting the service, being deducted from the number of lives yearly exposed to the climate, on the principle that the retirements themselves were probably scattered through the year in which they occurred, and a portion of them only exposed to Indian mortality for the whole period. With such extensive data, thus rendered available, the Table No. 25,† was at length compiled; and this may be deemed a fair criterion of the law of mortality and expectation of life under existing circumstances in India. At the more advanced ages, as individuals are for the most part in Europe, the Northampton Tables are adopted, which being less favorable to life than the Carlisle ascertained law of mortality, may more faithfully represent the state of the case as applicable to the Anglo-Indian community.

The calculations themselves in the greater portion of the Tables, were made by Mr. FERGUSSON, Auditor, King's Troops' Department, in the Military Auditor General's Office, and the result of these Tables generally, after due allowance for the errors, which must creep into tedious and voluminous operations of this nature, may be the more confidently relied upon when it is understood that, although wrought separately and perfectly apart, they will be found to agree in all main points with Mr. CURNIN's more elaborate Tables, and particularly so if reference be had to his data of the last twenty years only.

---

\* Vide Tables Nos. 22, 23 and 24.

† Vide Table No. 25.



TABLE I.—ABSTRACT shewing the strength, the proportion of Sick to strength, and ratio of Deaths to strength, per cent., for the undermentioned periods of Native Corps at the several Stations of the Army where European Troops are cantoned.

STATIONS.	Period of Corps remaining at Stations.	Total Strength by Monthly Average.	Average Strength.	Average of Admissions during the Year.	Proportion of Sick to Well.	NUMBER OF DEATHS.			General Ratio per Cent.
						Ordinary Diseases.	Cholera Morbus.	Total.	
Presidency, ...	For 5 years,.....	6720	1344	1089	1 to 14	171	22	193	2.83
	For 3 years,.....	406	135	270	1 to 5½	3	0	3	0.75
	Total,...	7126	1479	1359	2 to 19½	174	22	196	2.76
Barrackpore,...	For 3 years,.....	12990	4328	2943	1 to 17	274	10	284	2.15
	For 2 years,.....	2922	1461	1332	1 to 17	46	1	47	1.68
	For 1 year, .....	5363	5263	3006	1 to 15	46	3	49	0.94
Total,...	21175	11052	7281	3 to 49	366	14	380	1.80	
Dum-Dum, ...	For 5 years,.....	3640	725	612	1 to 10	46	7	53	1.28
	For 2 years,.....	264	132	141	1 to 11	4	0	4	1.34
	For 1 year, .....	110	110	117	1 to 12	3	0	3	3.00
Total,...	4014	967	870	3 to 33	53	7	60	1.50	
Berhampore, ...	For 3 years,.....	2250	750	558	1 to 21	24	2	26	1.15
	For 1 year, .....	1376	1376	821	1 to 20	8	0	8	0.55
	Total,...	3626	2126	1379	2 to 41	32	2	34	0.89
Dinapore, .....	For 3 years,.....	6660	2119	1043	1 to 31	45	8	53	0.71
	For 2 years,.....	1560	780	482	1 to 25	23	2	25	1.62
	For 1 year, .....	4660	4660	2180	1 to 26	24	3	27	0.61
Total,...	12880	7559	3705	3 to 82	92	13	105	0.82	
Bhagalpore,.....	For 5 years,.....	2327	465	233	1 to 23	20	2	22	0.96
Benares,.....	For 5 years,.....	579	115	53	1 to 22	3	1	4	4.71
	For 4 years,.....	2600	650	275	1 to 33	7	0	7	0.20
	For 3 years,.....	4116	1372	875	1 to 20	22	7	29	0.73
	For 2 years,.....	1682	841	114	1 to 25	10	0	10	0.60
	For 1 year, .....	1331	1331	402	1 to 29	3	1	4	0.40
Total,...	10308	4309	1719	5 to 129	45	9	54	0.52	
Chunar, .....	For 1 year, .....	291	291	208	1 to 16	1	0	1	0.33
Allahabad,.....	For 5 years,.....	2068	413	378	1 to 13	0	1	1	0.05
	For 3 years,.....	3696	1231	751	1 to 23	16	2	18	0.50
	For 2 years,.....	2964	1484	1314	1 to 20	18	0	18	0.59
	For 1 year, .....	2030	2030	723	1 to 25	6	5	11	0.53
Total,...	10758	5158	3166	4 to 81	40	8	48	0.44	

## RESULTS OF AN ENQUIRY RESPECTING THE

STATIONS.	Period of Corps remaining at Stations.	Total Strength by Monthly Average.	Average Strength.	Average of Admissions during the Year.	Proportion of Sick to Well.	NUMBER OF DEATHS.			General Ratio per Cent.
						Ordinary Diseases.	Cholera Morbus.	Total.	
Cawnpore, ...	For 5 years,.....	4390	878	844	1 to 19	16	1	17	0.38
	For 4 years,.....	806	201	143	1 to 18	10	1	11	1.35
	For 3 years,.....	9766	3253	1722	1 to 25	72	2	74	0.78
	For 2 years,.....	3540	1170	1127	1 to 25	14	0	14	0.42
	For 1 year, .....	5308	5308	2392	1 to 26	18	5	23	0.43
	Total,...	23810	11410	6228	5 to 113	130	9	139	0.58
Meerut,.....	For 5 years,.....	716	143	43	1 to 68	2	0	2	0.28
	For 4 years,.....	5410	1351	620	1 to 26	19	0	19	0.31
	For 3 years,.....	2315	771	400	1 to 16	8	1	9	0.39
	For 1 year, .....	3254	3254	2084	1 to 29	14	0	14	0.43
	Total,...	11695	5519	3147	4 to 139	43	1	44	0.38.
Agrah, .....	For 4 years,.....	3320	829	309	1 to 37	13	4	17	0.50
	For 3 years,.....	4294	1430	870	1 to 16	30	7	37	0.86
	For 2 years,.....	3001	1498	791	1 to 24	21	3	24	0.80
	For 1 year, .....	3370	3370	1319	1 to 27	15	0	15	0.47
	Total,...	13985	7127	3289	4 to 104	79	14	93	0.59
Muttra, .....	For 4 years,.....	2858	714	31	1 to 39	17	2	19	0.67
	For 3 years,.....	1867	622	349	1 to 21	15	2	17	0.90
	For 2 years,.....	1853	926	400	1 to 40	9	0	9	0.49
	For 1 year, .....	2269	2269	677	1 to 50	4	1	5	0.24
	Total,...	8847	4531	1457	4 to 150	45	5	50	0.56
Kurnaul,.....	For 4 years,.....	6500	1784	487	1 to 50	32	2	34	0.51
	For 3 years,.....	2064	687	480	1 to 20	6	0	6	0.29
	For 2 years,.....	4249	2124	943	1 to 27	10	0	10	0.24
	For 1 year, .....	3568	3568	1094	1 to 28	12	0	12	0.32
	Total,...	16381	8163	3004	4 to 125	60	2	62	0.38
Saugor,.....	For 5 years,.....	1726	345	118	1 to 83	2	0	2	0.11
	For 4 years, .....	3532	997	651	1 to 54	19	2	21	0.60
	For 3 years,.....	7079	2359	1533	1 to 50	31	5	36	0.50
	For 2 years,.....	2657	1378	842	1 to 23	18	0	18	0.75
	For 1 year, .....	1610	1610	828	1 to 19	5	0	5	0.30
	Total,...	16604	6689	3972	5 to 229	75	7	82	0.49
Nusseerabad & Neemuch, ...	For 5 years,.....	1036	207	170	1 to 15	5	0	5	0.49
	For 4 years,.....	7459	1864	1159	1 to 21	45	2	47	0.63
	For 3 years,.....	13956	4649	2141	1 to 24	49	3	52	0.38
	For 2 years,.....	3080	1543	610	1 to 22	0	10	10	0.32
	For 1 year, .....	10246	10246	4534	1 to 27	38	0	38	0.32
	Total,...	35777	18509	8614	5 to 109	137	15	152	0.42
Grand Total,...	Strength by monthly average, ...	199604	.....	.....	.....	.....	.....	1522	0.76

Medical Board Office, 5th Feb. 1834.

J. HUTCHINSON, Sec. Medl. Board.

**TAB. II.—STATEMENT** shewing the number of Deaths in the Invalid Pension Establishment (of Fighting Men) reported from 1st May 1831 to 30th April 1832; also the average of Age when pensioned and the duration of Pension.

	Number of Deaths.	Mean of Age, when Pensioned.			Mean of Number of Years of duration of Pension.		
		Years.	Months.	Days.	Years.	Months.	Days.
Subadar Majors, .....	5	61	9	18	5	0	0
Subadars, .....	60	59	3	24	6	8	23
Jemmadars, .....	20	57	1	6	4	8	1
Havildars and Naiks, .....	315	48	7	17	5	1	6
Trumpeters and Drummers, .....	7	55	5	4	1	10	4
Troopers, Sepoys and Privates, .....	273	46	6	8	5	6	6
Total and General Average, ....	680	49	1	22	5	4	12

**TAB. III.—STATEMENT** shewing the actual Deaths in Pension Establishment (Regular Army) reported from May 1828 to October 1830, or 2½ Years, also average of Age when pensioned and the duration of Pension.

	Number of Deaths.	Mean of Age, when Pensioned.			Mean of Number of Years of duration of Pension.		
		Years.	Months.	Days.	Years.	Months.	Days.
Subadar Majors, .....	6	73	7	0	2	3	12
Subadars, .....	76	60	8	22	8	4	3
Jemmadars, .....	28	58	10	14	7	7	0
Havildars and Naiks, .....	296	49	8	22	6	10	23
Drummers, .....	9	61	3	7	3	0	20
Sepoys, Privates and Troopers, .....	315	48	7	9	8	6	26
Total and General Average, ....	730	51	1	3	7	8	16

**TAB. IV.—RETURN** of the Strength of the — Regiment when it arrived in India in 1823; the numbers of Men who joined the Corps, and the numbers who died till 31st December 1829.

	Year.	Strength and Numbers who joined.	Died in the following Years.						
			1823.	1824.	1825.	1826.	1827.	1828.	1829.
Strength of the Corps when it arrived in India ..	1823	653	45	231	115	37	13	18	12
Recruits who joined in .....	1824	13	0	2	4	0	1	0	0
Do. do. do. in .....	1826	600	0	0	0	79	26	52	48
Do. do. do. in .....	1827	188	0	0	0	0	17	15	31
Do. do. do. in .....	1828	34	0	0	0	0	0	1	5
Do. do. do. in .....	1829	34	0	0	0	0	0	0	4
Volunteers from Regiments leaving India in ..	1823	620	3	105	32	15	3	8	6
Do. do. do. in ..	1826	29	0	0	0	3	0	1	1
Do. do. do. in ..	1827	7	0	0	0	0	0	2	0

**TAB. V.—STATEMENT** shewing the amount of Casualties by Death in the European Troops, at the several stations of the Army, when European Troops are stationed under the Presidency of Fort William, distinguishing those by Cholera Morbus, from those by ordinary Diseases and general proportion of the Sick to the Healthy, for the preceding 5 years, up to 31st December 1832.

## PRESIDENCY.

YEAR.	STATION.	CORPS.	Average Strength for 12 Months.	Admissions during the Year.	Average Admissions for 12 Months.	Proportion of Sick to Well.	Deaths by Ordinary Diseases.	Deaths by Cholera Morbus.
1828, .....	Fort William,	H. M.'s 59th Regt., .....	924	2021	168 $\frac{3}{4}$	1 to 5 $\frac{1}{2}$	36	13
1829, .....		Do. 16th Regt., .....	954	2079	173	1 to 5 $\frac{1}{2}$	55	14
1830, .....		Do. do., .....	985	1955	163	1 to 6	73	6
1831, .....		H. M.'s 16th & 3d Foot, ...	884	1197	99	1 to 9	56	4
1832, .....		Do. do., ....	785	1038	66	1 to 9	54	2
Total, .....	.....	.....	4532	8290	689	1 to 6 $\frac{1}{2}$	274	38
Average, .....	.....	.....	906	1658	138	1 to 6 $\frac{1}{2}$	55	7
Ratio per Cent., .....	.....	.....	....	183	....	15	6	3 $\frac{1}{2}$
General Ratio, .....	.....	.....	....	....	....	....	6 $\frac{1}{2}$	....

TABLE V.—Continued.

BARRACKPORE.																
YEAR.	STATION.	CORPS.	Average Strength for 12 Months.	Admissions during the Year.	Average Admissions for 12 Months.	Proportion of Sick to Well.	Deaths by Ordinary Diseases.	Deaths by Cholera Morbus.	STATION.	CORPS.	Average Strength for 12 Months.	Admissions during the Year.	Average Admissions for 12 Months.	Proportion of Sick to Well.	Deaths by Ordinary Diseases.	Deaths by Cholera Morbus.
1828, .....	Dum-Dum.	H. C. Arty., .....	1084½	2447	204	1 to 5½	46	13	Chinsurah.	H. M.'s Depôt, .....	197	560	48	1 to 4	12	7
1829, .....	..	H. C. Arty., .....	1037	1920	160	1 to 6½	30	3	..	Ditto ditto, .....	149	523	43	1 to 3½	9	6
1830, .....	..	H. C. Arty., .....	778	1735	144	1 to 5½	66	8	..	Ditto ditto, .....	322	800	65	1 to 5	18	6
1831, .....	..	H. C. Arty., .....	763	1967	165	1 to 4	38	1	..	H. M.'s 16th Regt. ....	927	1269	105	1 to 8½	54	5
1832, .....	..	H. C. Arty., .....	745	1487	122	1 to 6	46	6	..	H. M.'s 16th Regt. ....	804	1113	94	1 to 8½	43	2
Total, .....	..	.....	4897	9676	795	1 to 5½	226	31	..	.....	2389	4265	355	1 to 6½	136	26
Average, .....	..	.....	879	1915	159	1 to 5½	45	6	..	.....	479	853	71	1 to 6½	27	6
Ratio per Cent., ..	..	.....	.....	217½	.....	18	5	3½	..	.....	.....	178	.....	15	6	1
General Ratio, ..	..	.....	.....	.....	.....	.....	.....	5½	..	.....	.....	.....	.....	.....	.....	7

DINAPORE.																
YEAR.	STATION.	CORPS.	Average Strength for 12 Months.	Admissions during the Year.	Average Admissions for 12 Months.	Proportion of Sick to Well.	Deaths by Ordinary Diseases.	Deaths by Cholera Morbus.	STATION.	CORPS.	Average Strength for 12 Months.	Admissions during the Year.	Average Admissions for 12 Months.	Proportion of Sick to Well.	Deaths by Ordinary Diseases.	Deaths by Cholera Morbus.
1828, .....	Bhangulpore.	H. M.'s 3d Buffs, .....	604½	1132	94½	1 to 6½	50	26	Dinapore.	H. M.'s 13th Regt. & Arty., .....	699½	2272	189½	1 to 5½	95	3
1829, .....	..	Ditto ditto, .....	860	1677	139	1 to 5½	31	31	..	Ditto ditto, .....	1000	2594	199	1 to 5	111	4
1830, .....	..	Ditto ditto, .....	831	974	81	1 to 10	35	0	..	Ditto ditto, .....	861	1305	108	1 to 7	22	0
1831, .....	..	.....	0	0	0	0	0	0	..	Ditto ditto, .....	820*	1098	91	1 to 9	29	10
1832, .....	..	.....	0	0	0	0	0	0	..	H. C. Euro. Regt. Arty., .....	1087	2249	188	1 to 6½	82	1
Total, .....	..	.....	2295	3783	314	1 to 7	116	57	..	.....	4767	9318	775	1 to 6	239	18
Average, .....	..	.....	765	1261	104	1 to 7	39	19	..	.....	953	1863	155	1 to 6	48	3
Ratio per Cent., ..	..	.....	.....	162	.....	14	5	2½	..	.....	.....	195	.....	16	5	½
General Ratio, ..	..	.....	.....	.....	.....	.....	.....	7½	..	.....	.....	.....	.....	.....	.....	5½

\* H. M.'s 13th Regiment proceeded from Dinapore to Agra, during which no Returns were received for the months of November and December, 1831, consequently calculations are made for that year for 10 months only.

## RESULTS OF AN ENQUIRY RESPECTING THE

TABLE V.—Continued.

BERHAMPORE.								
YEAR.	STATION.	CORPS.	Average Strength for 12 Months.	Admissions during the Year.	Average Admissions for 12 Months.	Proportion of Sick to Well.	Deaths by Ordinary Diseases.	Deaths by Cholera Morbus.
1828, .....	Berham- pore.	H. M.'s 47th & 14th Regt., ..	1622	3993	332	1 to 5	54	45
1829, .....		H. M.'s 49th & 14th do., ..	1567	3444	287	1 to 5½	72	60
1830, .....		Do. do., ..	1183	2245	187	1 to 6¼	67	11
1831, .....		H. M.'s 49th & Arty., ..	808	1735	147	1 to 5½	59	2
1832, .....		Do. do., ..	783	1238	103	1 to 7¼	50	7
Total,.....	.....	.....	5963	12655	1053	1 to 5½	302	125
Average, .....	.....	.....	1192	2531	210	1 to 5½	60	25
Ratio per Cent., .....	.....	.....	....	212	....	17	6	2½
General Ratio,..	.....	.....	....	....	....	....	....	7½
ALLAHABAD.								
YEAR.	STATION.	CORPS.	Average Strength for 12 Months.	Admission during the Year.	Average Admissions for 12 Months.	Proportion of Sick to Well.	Deaths by Ordinary Diseases.	Deaths by Cholera Morbus.
1828, .....	Allahabad.	H. C. Arty. ....	79	284	24	1 to 3	19	0
1829, .....		Do. do. ....	117	356	29	1 to 4	7	0
1830, .....		Do. do. ....	123	430	35	1 to 3½	8	0
1831, .....		Do. do. ....	108	287	24	1 to 4	4	0
1832, .....		Do. do. ....	127	323	27	1 to 4	5	0
Total,.....	.....	.....	554	1680	139	1 to 4	43	0
Average, .....	.....	.....	110	336	28	1 to 4	8	0
Ratio per Cent. ....	.....	.....	....	305	....	25	8	0
General Ratio,..	.....	.....	....	....	....	....	8	0

TABLE V.—Continued.

YEAR.	BENARES.										AGRA.									
	STATION.	CORPS.	Average Strength for 12 Months.	Admissions during the Year.	Average Strength for 12 Months.	Proportion of Sick to Well.	Deaths by Ordinary Diseases.	Deaths by Cholera Morbus.	STATION.	CORPS.	Average Strength for 12 Months.	Admissions during the Year.	Average Strength for 12 Months.	Proportion of Sick to Well.	Deaths by Ordinary Diseases.	Deaths by Cholera Morbus.				
1828, .....	Chunar & Buxar.	H. C. Invalids, ...	296	826	68	1 to 4½	41	1	Benares.	H. C. Arty., ...	113	279	23	1 to 5	6	0				
1829, .....	.....	Ditto ditto, ...	804	687	57	1 to 5	22	0	.....	Ditto ditto, ...	180	360	31	1 to 4	7	1				
1830, .....	.....	Ditto ditto, ...	268	503	44	1 to 6½	29	0	.....	Ditto ditto, ...	91	182	15	1 to 6	2	0				
1831, .....	.....	Ditto ditto, ...	278	426	35	1 to 7½	43	4	.....	Ditto ditto, ...	133	261	21	1 to 6	3	0				
1832, .....	.....	Ditto ditto, ...	252	545	45	1 to 5½	12	0	.....	Ditto ditto, ...	117	295	24	1 to 5	1	1				
Total, .....	.....	.....	1418	2987	249	1 to 5½	147	5	.....	.....	584	1397	114	1 to 5	19	2				
Average, .....	.....	.....	263	597	49	1 to 5½	29	1	.....	.....	117	279	23	1 to 5	4	0				
Ratio per Cent., .....	.....	.....	.....	210	.....	18	10	0½	.....	.....	246	.....	.....	20	3½	.....				
General Ratio, .....	.....	.....	.....	.....	.....	.....	.....	104	.....	.....	.....	.....	.....	3½	.....	.....				
YEAR.	STATION.	CORPS.	Average Strength for 12 Months.	Admissions during the Year.	Average Strength for 12 Months.	Proportion of Sick to Well.	Deaths by Ordinary Diseases.	Deaths by Cholera Morbus.	STATION.	CORPS.	Average Strength for 12 Months.	Admissions during the Year.	Average Strength for 12 Months.	Proportion of Sick to Well.	Deaths by Ordinary Diseases.	Deaths by Cholera Morbus.				
1828, .....	Agra.	H. C. European Regt.,	981	2164	180	1 to 6½	21	0	Mullra.	H. C. Arty., .....	99	108	9	1 to 11	0	0				
1829, .....	.....	Ditto ditto, .....	1024	1454	121	1 to 8½	14	2	.....	Ditto ditto, .....	101	179	14	1 to 7	3	0				
1830, .....	.....	Ditto ditto, .....	1261	1756	146	1 to 8	25	0	.....	Ditto ditto, .....	104	184	16	1 to 7	2	0				
1831, .....	.....	Ditto ditto, .....	1277	1839	163	1 to 8	33	7	.....	Ditto ditto, .....	102	165	14	1 to 7	2	0				
1832, .....	.....	H. M.'s 13th Regt.,...	983	1007	84	1 to 11	14	0	.....	Ditto ditto, .....	100	150	12	1 to 8	0	0				
Total, .....	.....	.....	5526	8220	684	1 to 8	97	9	.....	.....	506	786	64	1 to 8	7	0				
Average, .....	.....	.....	1105	1644	157	1 to 8	19	2	.....	.....	101	157	15	1 to 8	1	0				
Ratio per Cent., .....	.....	.....	.....	148	.....	12½	14	0½	.....	.....	.....	155	.....	13	1½	0				
General Ratio, .....	.....	.....	.....	.....	.....	.....	1½	.....	.....	.....	.....	.....	.....	.....	1½	0				

TABLE V.—Continued.

CAWNPORE.								
YEAR.	STATION.	CORPS.	Average Strength for 12 Months.	Admissions during the Year.	Average Admissions for 12 Months.	Proportion of Sick to Well.	Deaths by Ordinary Diseases.	Deaths by Cholera Morbus.
1828, .....	Cawnpore.	H. M.'s 11th Drag. 38th } Regt. & Arty. ....	2184	3630	302	1 to 7	91	32
1829, .....		H. M.'s 11th Drag. 44th } Regt. & Arty. ....	2205	3406	283	1 to 7½	98	5
1830, .....		Do. do. do. ....	1960	3236	279	1 to 7	70	2
1831, .....		Do. do. do. ....	2045	3059	255	1 to 8	96	2
1832, .....		Do. do. do. ....	2003	3319	276	1 to 7	62	0
Total, .....				10397	16640	1395	1 to 7½	417
Average, .....			2079	3308	279	1 to 7½	83	8
Ratio per Cent., .....			.....	160	.....	13	4	↓
General Ratio, ...			.....	.....	.....	.....	4½	.....

MEERUT.								
YEAR.	STATION.	CORPS.	Average Strength for 12 Months.	Admissions during the Year.	Average Admissions for 12 Months.	Proportion of Sick to Well.	Deaths by Ordinary Diseases.	Deaths by Cholera Morbus.
1828, .....	Meerut.	H. M.'s 16th Lancers, 31st } Foot & Arty. ....	1845	3283	273	1 to 6	56	5
1829, .....		Do. do. do. ....	1823	2783	232	1 to 8	50	1
1830, .....		Do. do. do. ....	2009	2813	234	1 to 8½	36	4
1831, .....		Do. do. do. ....	1715	2010	177	1 to 10	42	1
1832, .....		H. M.'s 26th Foot, 11th Lt. } Drag. & Artillery, .....	1418	2105	175	1 to 11	50	1
Total, .....				9410	12994	1091	1 to 8½	234
Average, .....			1882	2599	218	1 to 8½	47	2
Ratio per Cent., .....			.....	136	.....	12	2½	↓
General Ratio, ...			.....	.....	.....	.....	2½	.....



TABLE V.—*Continued.*

KURNAUL.								
YEAR.	STATION.	CORPS.	Average Strength for 12 Months.	Admissions during the Year.	Average Admissions for 12 Months.	Proportion of Sick to Well.	Deaths by Ordinary Diseases.	Deaths by Cholera Morbus.
1828, .....	Kurnaul.	H. C. Arty., .....	166	214	18	1 to 9	5	0
1829, .....		Do. do., .....	291	574	48	1 to 6	11	1
1830, .....		Do. do., .....	222	293	24	1 to 9	5	0
1831, .....		H. M.'s 31st Regt., Arty., ...	1196	1558	129	1 to 9	33	0
1832, .....		Do. do., .....	1289	1650	137	1 to 9	41	0
Total, .....			3154	4289	356	1 to 8½	95	1
Average, .....			630	858	71	1 to 8½	19	0
Ratio per Cent., .....			.....	138	.....	11½	3	0
General Ratio, ...			.....	.....	.....	.....	3	.....

## SAUGOR.

YEAR.	STATION.	CORPS.	Average Strength for 12 Months.	Admissions during the Year.	Average Admissions for 12 Months.	Proportion of Sick to Well.	Deaths by Ordinary Diseases.	Deaths by Cholera Morbus.
1828, .....	Saugor.	H. C. Arty., .....	145	389	32	1 to 4½	26	0
1829, .....		Do. do., .....	84	169	14	1 to 6	2	0
1830, .....		Do. do., .....	101	204	17	1 to 6	3	0
1831, .....		Do. do., .....	110	316	26	1 to 4	7	0
1832, .....		Do. do., .....	86	242	20	1 to 4	2	0
Total, .....			526	1320	109	1 to 4½	40	0
Average, .....			105	264	22	1 to 4½	14	.....
Ratio per Cent., .....			.....	250	.....	20	7½	0
General Ratio, ...			.....	.....	.....	.....	7½	.....

TABLE V.—Continued.

NUSSEERABAD, FOR 1828, 29 & 30. NEEMUCH, FOR 1831 & 1832.								
YEAR.	STATIONS.	CORPS.	Average Strength for 12 Months.	Admissions during the Year.	Average Admissions for 12 Months.	Proportion of Sick to Well.	Deaths by Ordinary Disease.	Deaths by Cholera Morbus.
1828, .....	Nusseerabad and Neemuch.	H. C. Arty., .....	163	288	24	1 to 7	2	0
1829, .....		Do. do., .....	312	730	60	1 to 5	12	0
1830, .....		Do. do., .....	290	606	50	1 to 6	13	0
1831, .....		Do. do., .....	309	927	77	1 to 4	11	11
1832, .....		Do. do., .....	109	597	49	1 to 2	4	0
Total, .....		.....	.....	1183	3148	260	1 to 5	42
Average, .....	.....	.....	236	629	52	1 to 5	8	2
Ratio per Cent., .....	.....	.....	.....	285	.....	22	3½	1
General Ratio, ...	.....	.....	.....	.....	.....	.....	4½	.....

## ABSTRACT, shewing the several Ratio per Cent. of the within Statement.

STATIONS.	Strength for 5 Years.	Of Sick to Well according to Total Admissions for 5 Years.	Of Sick to Well by Monthly Average.	Death by Ordinary Diseases to Strength.	Do. do. by Cholera Morbus to Strength.	General Ratio.
Fort William, .....	4532	183	15	6	½	6.75
Dum Dum, .....	4397	217½	16	5	½	5.75
Chinsurah, .....	2399	178	15	6	1	7
Berhampore, .....	5963	212	17	5	2½	7.50
Bhaugulpore, .....	2295	162	14	5	2½	7.50
Dinapore, .....	4767	195	16	5	½	5.33
Chunar and Buxar, .....	1418	210	18	10	½	10.33
Benares, .....	584	246	20	3½	.....	3.75
Ghazeepore, .....	4801	150	12	3½	1½	5
Allahabad, .....	554	305	25	8	.....	8
Cawnpore, .....	10397	160	13	4	½	4.14
Meerut, .....	9410	136	12	2½	½	2.62
Agra, .....	5526	148	12½	1½	.....	1.91
Muttra, .....	506	155	13	1½	.....	1.50
Kurnaul, .....	3154	138	11½	3	.....	3
Saugor, .....	526	250	20	7½	.....	7.50
Neemuch, .....	1183	285	22	3½	1	4.60
						5.50

Fort William, Medical Board Office.

J. HUTCHINSON,

Secy. Medical Board.

TABLE VI.—STATEMENT of Burials of Europeans and East Indians at the Park Street Protestant Burial Ground, for the Years mentioned, with the Ages of the Deceased, from 1814 to 1833, both inclusive.

Age at which the Death took place.	Number of Burials in																			Total Deaths at the different Ages.	
	1814.	1815.	1816.	1817.	1818.	1819.	1820.	1821.	1822.	1823.	1824.	1825.	1826.	1827.	1828.	1829.	1830.	1831.	1832.		1833.
Year.																					
1	0	2	13	12	16	17	23	23	20	35	40	29	18	24	44	18	19	31	23	29	436
2	2	4	7	8	9	9	10	14	17	7	12	11	8	11	14	6	6	11	12	12	190
3	1	0	1	5	5	5	3	7	5	4	3	5	7	9	9	4	0	6	2	5	87
4	2	1	2	2	4	1	5	0	4	6	5	7	4	2	5	2	2	3	6	6	69
5	2	0	3	0	3	1	1	4	2	3	4	3	3	1	3	2	1	2	3	4	45
6	1	0	0	2	1	2	0	0	3	3	4	4	3	3	1	2	2	1	1	1	34
7	1	1	1	1	0	2	3	2	4	3	0	0	3	1	1	0	0	2	2	4	31
8	1	1	2	1	2	0	0	3	2	2	2	1	3	4	0	3	0	0	3	6	36
9	0	0	0	2	3	1	1	2	8	4	3	2	4	0	0	2	2	0	2	3	37
10	0	0	0	0	4	1	1	0	2	4	1	0	0	2	2	1	1	0	0	2	25
11	0	0	2	2	0	1	1	0	0	1	0	0	4	2	3	2	3	4	3	1	29
12	0	1	0	0	0	0	0	3	3	5	1	1	2	6	0	3	0	1	0	2	28
13	0	2	1	2	0	1	1	1	1	1	2	2	3	1	2	0	4	1	1	1	29
14	2	0	0	2	1	0	2	2	2	3	0	0	3	3	2	0	4	2	4	4	35
15	1	2	0	4	1	2	4	3	3	1	1	2	1	4	1	2	0	2	1	5	40
16	1	2	1	1	3	2	2	2	3	0	1	2	1	2	1	0	0	2	2	1	29
17	0	0	2	2	3	1	3	4	4	2	1	4	1	5	4	4	2	4	4	4	49
18	1	1	2	0	3	2	3	4	4	8	9	1	4	4	4	3	5	7	4	7	76
19	2	3	2	7	7	3	5	5	6	3	3	2	8	2	3	4	3	1	2	4	75
20	1	3	2	6	1	7	5	4	4	3	3	4	7	2	4	1	2	0	3	4	66
21	6	2	3	2	5	3	8	5	6	4	3	1	6	3	5	2	5	2	4	5	80
22	3	0	2	3	7	7	9	7	10	8	4	9	5	3	6	3	7	2	7	7	109
23	2	3	8	7	8	12	5	3	7	8	6	8	3	8	4	5	4	3	4	5	113
24	2	1	4	4	6	8	9	3	9	3	9	7	4	7	3	2	1	6	3	9	99
25	2	4	2	6	5	10	11	5	6	9	10	11	7	7	3	3	5	6	6	6	124
26	1	2	3	5	7	16	6	8	7	5	5	15	8	4	2	0	6	4	6	9	119
27	1	4	3	2	6	8	6	4	10	5	6	3	8	4	5	7	2	1	7	8	100
28	4	3	3	3	5	8	8	5	16	6	11	13	10	12	7	4	7	2	5	10	142
29	3	4	2	3	5	8	6	3	8	4	6	8	4	8	6	4	4	8	10	10	

RESULTS OF AN ENQUIRY RESPECTING THE

TAB. VII.—FIFTH LAUDABLE SOCIETY—1822-27.

AGE.	Lapsed within, from Insurance,										Total Lapses.	Total number of Lives Insured.	Rate per Cent. of Lapses.
	1 Year.	2 Years.	3 Years.	4 Years.	5 Years.	6 Years.	7 Years.	8 Years.	9 Years.	10 Years.			
16 a 20,.....	.....	.....	.....	.....	.....	.....	.....	.....	.....	.....	.....	23	0
20 a 35,.....	22	25	4	5	7	9	7	10	5	7	101	748	13.500
35 a 50,.....	12	7	13	8	5	2	3	2	3	4	59	496	11.895
50 a 70,.....	1	8	2	3	3	0	2	1	4	3	27	123	21.960
	35	40	19	16	15	11	12	13	12	14	187	1390	13.453

*Shares.*

Age 20 a 35— No. of Lives lapsed 101 on which 206 Shares were held, average 2.04 each Lapse.  
 „ 35 a 50 „ „ „ „ 59 „ „ 261 „ „ „ „ 4.42 ditto.  
 „ 50 & upwards „ „ „ „ 27 „ „ 147 „ „ „ „ 5.44 ditto.

Total, ... 187 lapsed Lives. 614 Shares.                      Average 3.28

TAB. VIII.—SIXTH LAUDABLE SOCIETY.

STATEMENT shewing the number of Shares which were transferred from the 5th to the 6th Laudable Society on the 1st January 1827—also the number of Lives on which those Shares were held, and the Lapses which have taken up to 31st December 1831.

Number of Shares transferred from 5th to 6th Laudable Society, ..... 2741  
 Number of Lives on which the above Shares were held, ..... 996  
 Number of Lives Lapsed up to 31st December 1831, out of the above, ..... 180  
 Number of Shares held on the above Lapsed Lives, ..... 520

“ The above 520 Shares being held on 180 Lives lapsed out of 996 Lives and 2741 Shares, gives an average of 2½ Shares on each Lapsed Life, and a ratio of Lapses of 18 per Cent. in 5 years.”

18 per Cent. in 5 years gives 3.6 per Cent. per Annum.

TAB. IX.—NUMBER of Lives Insured at the ORIENTAL LIFE INSURANCE COMPANY, with the Lapses from ditto, from 1822 to 1833, or a term of 12 years.

	Under 25 years of Age.	From 25 to 30 years of Age.	30 to 35	35 to 40	40 to 45	45 to 50	50 to 55	55 & upwards.	TOTAL.
Number Insured,.....	449	384	337	300	164	83	46	18	1781
Ditto Lapsed, .....	36	67	60	66	71	39	21	15	373
Percentage, .....	8.018	17.44	17.80	22.00	43.29	46.99	45.65	72.22	20.38

TAB. X.—BOMBAY MILITARY SERVANTS.

1st OF JANY.	STRENGTH.			INCREASE.			DECREASE BY DEATHS.		
	Year.	Officers.	Medical Officers.	Total.	Cadets.	Assist. Surgeons.	Total.	Officers.	Medical Officers.
1789	210	35	245	8	1	9	0	0	0
1790	215	34	249	12	11	23	6	0	6
1791	220	45	265	27	9	36	9	0	9
1792	238	46	284	17	1	18	1	0	1
1793	250	48	298	4	0	4	12	0	12
1794	225	48	273	5	4	9	8	2	10
1795	208	50	258	6	0	6	10	3	13
1796	206	47	253	27	1	28	5	3	8
1797	226	45	271	36	4	40	16	7	23
1798	246	42	288	75	11	86	3	2	5
1799	318	51	369	31	18	49	20	0	20
1800	329	69	398	41	4	45	18	5	23
1801	351	68	419	108	7	115	12	2	14
1802	436	72	508	38	6	44	20	7	27
1803	437	62	499	20	1	21	20	2	22
1804	432	61	493	65	6	71	14	3	17
1805	473	64	537	119	6	125	33	5	38
1806	560	65	625	29	5	34	17	9	26
1807	545	61	606	20	5	25	29	2	31
1808	524	62	586	23	12	35	22	3	25
1809	522	72	594	50	10	60	20	1	21
1810	529	80	609	32	5	37	10	1	11
1811	528	84	612	34	6	40	19	3	22
1812	530	85	615	30	0	30	13	3	16
1813	540	82	622	8	7	15	12	4	16
1814	538	85	623	18	5	23	21	0	21
1815	515	90	605	8	1	9	11	6	17
1816	499	86	585	7	7	14	10	1	11
1817	498	88	577	12	7	19	13	1	14
1818	488	89	577	55	7	62	13	5	18
1819	484	85	569	81	16	97	23	10	33
1820	556	91	647	99	11	110	22	3	25
1821	563	97	660	122	13	135	36	8	44
1822	670	102	772	0	0	0	0	0	0
Total,...	14100	2291	16391	1267	207	1474	498	101	599

## RESULTS OF AN ENQUIRY RESPECTING THE

TABLE X.—Continued.

Shewing the rate of Mortality among the Military Officers at Bombay.

Age.	Number Living.	Decrement.	Number Living at the middle of next year.	Sum.	Expectation of Life.	Age.	Number Living.	Decrement.	Number Living at the middle of next year.	Sum.	Expectation of Life.
Years.						Years.					
18	9964	369	9779	236872	23.77	57	2287	85	2245	33419	14.61
19	9596	355	9418	227093	23.67	58	2202	82	2161	31174	14.15
20	9240	343	9068	217675	23.56	59	2120	82	2079	29013	13.68
21	8897	329	8733	208607	23.45	60	2038	82	1997	26934	13.21
22	8568	317	8409	199874	23.33	61	1956	82	1915	24937	12.75
23	8251	306	8098	191465	23.20	62	1874	81	1833	23022	12.28
24	7945	294	7798	183367	23.08	63	1793	81	1753	21189	11.81
25	7651	284	7509	175569	22.95	64	1712	80	1672	19436	11.35
26	7367	272	7231	168060	22.81	65	1632	80	1592	17764	10.88
27	7095	263	6964	160829	22.67	66	1552	80	1512	16172	10.42
28	6832	253	6705	153865	22.62	67	1472	80	1432	14660	9.96
29	6579	244	6457	147160	22.37	68	1392	80	1352	13228	9.50
30	6335	235	6218	140703	22.21	69	1312	80	1272	11876	9.05
31	6100	228	5987	134485	22.05	70	1232	80	1192	10604	8.60
32	5874	217	5765	128495	21.88	71	1152	80	1112	9412	8.17
33	5657	210	5552	122733	21.69	72	1072	80	1032	8300	7.74
34	5447	201	5347	117181	21.51	73	992	80	952	7268	7.33
35	5246	195	5148	111834	21.32	74	912	80	872	6316	6.92
36	5051	187	4958	106686	21.12	75	832	80	792	5444	6.54
37	4864	180	4774	101728	20.91	76	752	77	713	4652	6.18
38	4684	173	4598	96954	20.70	77	675	73	639	3939	5.83
39	4511	167	4428	92356	20.47	78	602	68	568	3300	5.48
40	4344	161	4263	87928	20.24	79	534	65	501	2732	5.11
41	4183	155	4106	83665	20.00	80	469	63	438	2231	4.75
42	4028	149	3953	79559	19.75	81	408	60	376	1793	4.41
43	3879	144	3807	75606	19.49	82	346	57	317	1417	4.09
44	3735	138	3666	71799	19.22	83	289	55	262	1100	3.80
45	3597	134	3530	68133	18.94	84	234	48	210	838	3.58
46	3463	128	3399	64603	18.66	85	186	41	165	628	3.37
47	3335	123	3274	61204	18.35	86	145	34	128	463	3.19
48	3212	119	3152	57930	18.04	87	111	28	97	335	3.01
49	3093	115	3036	54778	17.71	88	83	21	73	238	2.86
50	2978	110	2923	51742	17.37	89	62	16	54	165	2.66
51	2868	106	2815	48819	17.02	90	46	12	40	111	2.41
52	2762	103	2710	46004	16.65	91	34	10	29	71	2.09
53	2659	98	2610	43294	16.28	92	24	8	20	42	1.75
54	2561	95	2514	40684	15.89	93	16	7	12	22	1.37
55	2466	91	2420	38170	15.48	94	9	5	7	10	1.11
56	2375	88	2331	35750	15.05	95	4	3	2	3	0.75
.....	.....	.....	.....	.....	.....	96	1	1	1	1	0.50

TABLE XI.—TABLE shewing the Casualties among Officers of the Bengal Army, (Hon. Company's Service) from the year 1814 to 1833, with the average percentage for each class and for each year.

Year.	COLONELS.		LT.-COLS.		MAJORS.		CAPTAINS.		LIEUTS.		CORNETS AND ENSIGNS.		TOTAL.		Yearly Percentage.
	Strength.	No. Died.	Strength.	No. Died.	Strength.	No. Died.	Strength.	No. Died.	Strength.	No. Died.	Strength.	No. Died.	Strength.	No. Died.	
1814	33	3	77	6	75	3	249	4	778	20	453	11	1665	47	2.82
1815	44	0	82	3	81	1	271	11	853	26	311	5	1642	46	2.80
1816	36	3	82	2	81	1	269	11	849	19	247	4	1564	40	2.56
1817	44	3	91	2	83	2	277	12	853	15	196	6	1544	40	2.59
1818	44	2	92	9	85	4	283	17	864	36	180	8	1548	76	4.90
1819	45	4	95	5	87	3	368	16	819	38	143	2	1555	68	4.37
1820	44	5	99	0	99	10	360	6	854	28	265	10	1721	59	3.42
1821	44	2	98	6	100	6	349	10	849	20	256	9	1696	53	3.12
1822	44	3	98	4	98	5	345	10	848	20	332	11	1765	53	3.00
1823	45	5	95	6	96	5	346	13	844	20	404	3	1830	52	2.84
1824	48	10	103	7	102	4	375	18	934	28	266	9	1828	76	4.15
1825	89	3	101	5	97	2	455	25	900	38	294	9	1936	82	4.23
1826	97	4	112	7	102	5	498	22	967	29	220	7	1996	74	3.70
1827	99	4	110	4	100	0	499	17	980	34	371	7	2159	66	3.00
1828	101	6	113	7	103	7	510	14	991	12	393	10	2211	56	2.53
1829	102	5	114	3	102	4	512	18	1000	23	451	8	2281	61	2.70
1830	101	6	113	6	103	3	511	12	973	20	519	9	2320	56	2.41
1831	101	5	109	4	102	3	514	16	927	24	538	17	2291	69	3.00
1832	101	3	110	5	103	4	513	12	863	23	528	9	2218	56	2.62
1833	101	5	108	6	103	6	521	13	838	17	510	7	2181	54	2.47
Total of each Rank,...	1363	81	2002	97	1902	78	8023	277	17784	490	6877	161	37951	1184	
Percentage of each Rank,...	5.94		4.84		4.10		3.45		2.75		2.34		3.12		

Memo. of the number of Officers who were killed or died from wounds received in action, included in this Table—

In the year 1814, .....	No. 13	In the year 1821, .....	No. 2
1815, .....	7	1824, .....	7
1816, .....	1	1825, .....	1
1817, .....	2	1826, .....	2
1818, .....	2	1829, .....	2
			<u>Total,..... 39</u>

RESULTS OF AN ENQUIRY RESPECTING THE

TABLE XII.—TABLE shewing the Decrements among the Officers of the Madras Army, (Honorable Company's Service) from the year 1814 to 1833 inclusive.

Year.	COLONELS.		LT.-COLS.		MAJORS.		CAPTAINS.		LIEUTS.		CORNETS AND ENSIGNS.		SURGEONS.		ASSISTANT SURGEONS.		TOTAL.		REMARKS.
	Strength.	No. of Deaths.	Strength.	No. of Deaths.	Strength.	No. of Deaths.	Strength.	No. of Deaths.	Strength.	No. of Deaths.	Strength.	No. of Deaths.	Strength.	No. of Deaths.	Strength.	No. of Deaths.	Strength.	No. of Deaths.	
1814	31	0	62	5	62	3	207	4	661	29	194	6	58	0	117	0	1392	43	1 Lieut. killed in action. 2 Lieuts. ditto ditto. 2 Captains, 5 Lieuts, 1 Ensign, & 1 Assist. Surgeon ditto ditto. 1 Captain, 8 Lieutenants, and 1 Ensign ditto ditto.  1 Major, 3 Captains, and 6 Lieuts. do. do. 1 Colonel, 1 Capt., and 1 Lieut. ditto ditto. 2 Captains and 2 Lieutenants ditto ditto.  1 Lieutenant ditto ditto. 1 Lieut. and 1 Ensign ditto ditto. 1 Major ditto ditto.
1815	31	3	62	2	62	4	207	8	661	24	187	3	63	4	114	4	1387	48	
1816	31	0	62	5	62	3	207	10	661	24	170	1	62	5	116	5	1371	53	
1817	31	3	62	6	62	3	207	10	661	43	131	5	62	3	117	7	1333	90	
1818	29	3	58	6	61	1	203	12	651	52	115	9	62	2	118	6	1297	91	
1819	33	1	66	8	65	9	224	16	617	39	69	8	66	6	116	4	1256	91	
1820	33	2	69	2	78	4	278	16	569	32	22	1	66	6	116	9	1231	72	
1821	34	2	69	4	77	2	276	16	694	27	134	10	66	4	112	12	1462	76	
1822	34	2	69	2	77	2	277	8	696	18	213	12	66	2	128	7	1560	53	
1823	34	2	69	2	77	6	277	13	699	26	281	6	65	2	128	5	1630	62	
1824	68	4	68	4	71	6	304	35	664	47	193	8	70	7	130	7	1568	118	
1825	68	4	68	4	70	5	340	25	661	31	211	12	70	2	129	7	1617	90	
1826	70	3	67	8	69	3	340	19	665	29	210	7	70	2	124	6	1615	77	
1827	70	3	70	3	70	3	350	14	683	30	302	5	70	0	123	4	1738	62	
1828	70	7	70	4	70	3	350	13	696	13	321	14	72	2	137	3	1786	59	
1829	70	2	70	3	70	1	349	21	692	9	326	12	72	4	138	8	1787	58	
1830	70	1	70	3	70	3	349	14	694	25	321	13	70	2	150	1	1736	62	
1831	70	5	70	5	70	2	350	18	617	26	312	8	72	2	154	5	1715	71	
1832	70	3	70	3	70	5	350	9	604	14	307	11	72	1	150	6	1693	52	
1833	70	5	70	5	70	7	350	11	589	17	296	13	72	6	155	5	1672	69	
Total of each,	1017	55	1341	82	1363	75	5795	201	13075	546	4315	164	1346	63	2572	111	30946	1387	43 Officers killed in action or died of wounds.
Percentage,	6.40	6.11	6.42	5.02	4.17	3.80	4.68	4.31	4.49										



TAB. XIII.—TABLE showing the Decrements among the Officers of the Bombay Army, (Honorable Company's Service) from the year 1804 to 1833 inclusive.

Year.	COLONELS.		LT.-COLS.		MAJORS.		CAPTAINS.		LIEUTS.		CORNETS AND ENSIGNS.		SURGEONS.		ASSISTANT SURGEONS.		TOTAL.		Percentage of each Year.	REMARKS.
	Strength.	No. of Deaths.	Strength.	No. of Deaths.	Strength.	No. of Deaths.	Strength.	No. of Deaths.	Strength.	No. of Deaths.	Strength.	No. of Deaths.	Strength.	No. of Deaths.	Strength.	No. of Deaths.	Strength.	No. of Deaths.		
1804	9	0	25	0	22	1	106	6	246	6	7	0	30	1	35	1	480	15	3.12	{ 1 Captain and 1 Ensign killed in action.
1805	13	0	22	3	23	1	108	14	256	12	37	3	31	3	39	4	529	40	7.56	
1806	13	2	22	2	24	0	110	3	254	10	118	5	30	5	34	3	605	30	4.95	
1807	13	0	22	0	24	1	109	6	254	18	108	3	32	0	31	2	591	30	5.07	
1808	13	1	25	1	24	1	108	3	254	4	103	2	32	3	45	0	601	15	2.49	
1809	11	1	25	0	25	1	106	9	255	11	112	2	29	0	53	0	616	24	3.90	
1810	12	0	24	1	25	4	106	2	256	6	105	3	29	0	58	1	615	17	2.76	
1811	16	0	20	0	27	2	106	4	339	10	105	3	27	2	61	2	701	23	3.28	
1812	18	0	18	0	28	0	105	5	258	7	111	2	27	1	59	2	622	17	2.73	
1813	18	0	18	2	28	0	105	2	259	9	113	0	27	0	63	3	628	16	2.54	
1814	18	1	20	2	28	1	103	2	259	15	90	4	27	0	63	1	608	26	4.27	
1815	21	1	17	1	35	1	93	5	256	6	65	1	27	0	61	2	575	17	3.00	
1816	20	1	18	1	31	1	128	2	225	4	58	0	27	1	62	1	570	11	1.93	
1817	20	2	18	1	31	1	128	4	225	10	58	1	27	0	62	2	569	21	3.70	
1818	18	1	26	2	30	1	129	6	233	10	42	0	32	3	59	6	569	29	5.09	
1819	17	2	30	4	31	1	189	7	149	15	86	1	33	3	59	6	604	39	6.45	
1820	17	1	30	2	31	0	188	9	236	18	49	1	31	1	64	5	646	37	5.72	
1821	14	2	40	4	35	1	176	15	303	19	39	2	38	4	62	6	707	53	7.49	
1822	14	1	40	4	35	2	160	3	334	9	72	4	37	4	73	2	765	29	3.79	
1823	12	2	40	3	34	1	158	3	346	16	117	3	37	2	68	2	812	31	3.81	
1824	9	2	59	0	33	2	180	9	344	14	120	8	40	1	72	3	857	39	4.55	
1825	10	0	59	4	33	2	180	6	344	12	119	3	40	1	71	6	856	34	4.00	
1826	7	1	61	5	33	2	178	12	335	20	134	10	40	1	73	3	861	54	6.27	
1827	6	0	68	2	36	1	185	7	316	23	116	5	43	0	89	2	904	40	4.42	
1828	34	0	38	3	36	2	185	2	361	12	130	5	43	1	93	7	920	32	3.47	
1829	36	1	36	2	36	1	185	8	366	10	169	1	42	3	101	3	971	29	3.00	
1830	37	2	37	1	37	0	185	2	358	11	172	7	42	1	105	2	973	26	2.67	
1831	37	2	37	2	37	2	186	2	348	7	215	3	43	0	97	2	990	20	2.00	
1832	37	1	38	1	38	2	187	4	316	13	152	8	43	1	103	3	914	33	3.61	
1833	37	5	38	0	38	0	187	3	316	5	152	7	43	0	102	3	913	23	2.51	
Total of each Rank.....	557	32	971	53	928	35	4559	165	8601	341	3072	97	1029	42	2017	85	21572	850		{ 18 Officers killed in action or died from wounds.
Percentage,	5.74		5.45		3.77		3.78		3.96		3.15		4.08		4.21		3.94			

## RESULTS OF AN ENQUIRY RESPECTING THE

TAB. XIV.—DECREMENTS in the different Ranks of Officers in the Bengal Pilotage Establishment, from 1804 to 1833 inclusive.

Year.	BRANCH PILOTS.			MASTERS.			1ST MATES.			BOATSWAIN, OR 2D MATES.			SEAMEN, OR VOLUNTEERS.			TOTALS.		
	Establishment.	Died.	Drowned.	Establishment.	Died.	Drowned.	Establishment.	Died.	Drowned.	Establishment.	Died.	Drowned.	Establishment.	Died.	Drowned.	Establishment.	Died.	Drowned.
1804	12	0	0	30	1	1	25	1	0	25	0	0	50	1	2	142	3	3
1805	12	2	0	30	0	0	25	3	0	25	0	0	58	1	0	150	6	0
1806	12	1	0	30	2	0	24	1	0	23	1	0	60	1	1	149	6	1
1807	12	0	0	30	0	0	24	2	1	24	0	1	58	0	0	148	2	2
1808	12	0	0	30	2	0	24	1	0	24	0	0	61	3	0	151	6	0
1809	12	0	0	24	0	0	24	0	0	24	0	0	45	0	0	129	0	0
1810	12	0	0	24	0	0	24	1	0	24	0	0	48	1	1	132	2	1
1811	12	1	0	24	1	0	24	0	0	25	1	1	36	1	0	121	4	1
1812	12	1	0	24	1	0	24	1	0	24	8	0	40	1	0	124	7	0
1813	12	0	0	22	0	0	23	0	0	23	1	0	47	1	0	127	2	0
1814	12	1	0	24	1	1	23	1	0	24	1	0	48	0	1	131	4	2
1815	12	0	0	24	0	0	24	1	0	24	0	0	50	1	0	134	2	0
1816	12	1	0	21	1	0	24	1	0	24	2	0	61	3	0	142	6	0
1817	12	0	0	24	2	0	24	2	1	24	0	0	70	1	4	154	5	5
1818	12	0	0	24	0	0	24	0	0	24	1	0	68	4	0	152	5	0
1819	12	0	0	24	2	0	24	1	0	24	0	0	73	2	0	157	5	0
1820	12	0	0	24	1	0	24	0	0	24	1	0	80	0	1	164	2	1
1821	11	0	0	24	1	0	24	0	0	24	0	0	76	3	2	159	4	2
1822	12	0	0	24	2	0	24	2	0	24	0	0	80	2	0	164	6	0
1823	12	2	0	24	2	1	24	3	0	24	0	0	72	2	4	156	9	5
1824	12	1	0	24	2	1	24	3	0	24	0	0	62	5	1	146	11	2
1825	12	0	0	24	0	0	24	0	0	24	1	0	67	1	0	151	2	0
1826	12	1	0	24	1	0	24	4	1	24	0	0	62	5	0	146	11	1
1827	12	0	1	24	1	0	24	3	0	24	1	0	59	0	0	143	5	1
1828	12	0	0	24	0	0	24	0	0	24	0	0	61	8	0	145	8	0
1829	12	0	0	24	0	0	24	0	0	24	1	0	56	2	0	140	3	0
1830	12	1	0	24	0	0	24	0	0	24	0	0	51	1	0	135	2	0
1831	12	1	0	24	0	0	24	1	0	24	1	0	45	1	0	129	4	0
1832	12	0	0	24	2	0	24	0	0	24	1	0	37	1	2	121	4	2
1833	12	1	1	24	3	0	24	1	0	24	2	0	23	3	1	107	10	2
	359	14	2	745	28	4	720	33	3	721	18	2	1704	50	20	4249	143	31
Percentage of Natural Deaths, ...	...	3.90	...	...	3.75	...	...	4.58	...	...	2.49	...	...	2.93	...	...	3.36	...
Total percentage, including Drowning,	...	4.45	...	...	4.30	...	...	5	...	...	2.77	...	...	4.10	...	...	4.09	...

Tab. XV.—TABLE shewing the Decrements among Officers of His Majesty's Regiments on the Bengal Establishment, from the year 1814 to 1833 inclusive.

Year.	LIEUT.-COLS.		MAJORS.		CAPTS.		LIEUTS.		CORNETS AND ENSIGNS.		PAYMASTERS.		ADJUTANTS.		QR. MASTERS.		SURGS.		ASSIST. SURGS.		VETERINARY SURGS.		TOTAL.		REMARKS.	
	Strength.	Deaths.	Strength.	Deaths.	Strength.	Deaths.	Strength.	Deaths.	Strength.	Deaths.	Strength.	Deaths.	Strength.	Deaths.	Strength.	Deaths.	Strength.	Deaths.	Strength.	Deaths.	Strength.	Deaths.	Strength.	Deaths.		
1814	15	0	15	1	76	2	164	4	65	2	7	1	7	0	7	1	7	0	7	0	15	2	2	390	13	{ 1 Lieut. and 1 Qr. Master killed in action. }  { 7 Lieuts. killed in action. } { 1 Capt. and 2 Lieuts. do. } { 1 Lieut. Col. and 1 Lieut. ditto. }
1815	17	0	17	0	85	3	184	3	72	2	9	0	9	0	9	0	9	0	9	17	1	2	0	430	9	
1816	18	0	18	2	87	1	190	13	73	2	9	1	9	0	9	1	9	0	17	0	2	0	0	442	20	
1817	17	1	17	0	81	0	175	11	69	1	8	0	8	0	8	1	8	0	17	4	2	0	0	410	18	
1818	16	0	16	0	73	4	156	4	63	1	8	0	8	0	8	1	8	1	16	0	3	0	0	375	11	
1819	15	0	15	0	69	3	147	5	59	1	7	0	7	0	7	1	7	0	15	0	2	0	0	350	10	
1820	14	0	14	0	66	2	142	9	56	0	7	1	7	0	7	1	7	1	14	0	2	0	0	336	12	
1821	14	1	14	0	66	2	142	2	56	1	7	0	7	0	7	1	7	1	14	1	2	0	0	336	9	
1822	16	0	16	1	75	0	163	4	64	1	8	0	8	0	8	0	8	0	16	1	2	0	0	384	7	
1823	16	2	16	1	73	4	169	2	62	1	8	1	8	0	8	0	8	0	16	0	2	0	0	375	11	
1824	16	0	16	1	76	4	164	11	64	1	8	0	8	0	8	1	8	0	16	0	2	0	0	386	18	
1825	18	2	18	1	88	6	190	12	73	1	9	0	9	0	9	0	9	0	18	1	2	0	0	443	23	
1826	21	4	21	1	100	8	217	10	83	3	10	2	10	0	10	0	10	1	21	1	2	0	0	505	30	
1827	20	1	20	2	93	1	200	5	77	3	10	0	10	0	10	1	10	0	20	0	2	0	0	472	13	
1828	20	1	20	1	96	6	208	4	80	3	10	0	10	0	10	0	10	1	20	1	2	0	0	486	17	
1829	20	0	20	0	94	3	204	6	77	0	10	2	10	0	10	0	10	0	20	0	2	0	0	2	477	
1830	20	0	20	0	90	2	205	6	74	1	10	1	10	0	10	0	10	0	20	0	2	0	0	2	471	10
1831	20	1	20	0	88	1	192	6	72	0	10	0	10	0	10	0	10	0	20	0	2	0	0	2	464	9
1832	20	0	20	0	88	5	192	7	72	0	10	0	10	0	10	1	10	0	20	1	2	0	0	2	454	14
1833	20	1	20	2	88	2	192	11	72	2	10	0	10	0	10	0	10	0	20	0	2	0	0	2	454	18
Total,.....	353	14	353	13	1652	58	3586	135	1383	27	175	9	175	0	175	9	175	5	352	13	41	1	8420	284		
Percentage of each Rank, ... }	3.96		3.68		3.51		3.76		2		5.15		0		5.15		2.86		3.69		2.44		3.37			

RESULTS OF AN ENQUIRY RESPECTING THE

Tab. XVI.—TABLE showing the Decrements among Officers of His Majesty's Regiments on the Madras Establishment, from the year 1814 to 1833 inclusive.

Year.	LIEUT.-COLS.		MAJORS.		CAPTS.		LIEUTS.		CORNETS AND ENSIGNS.		PAYMASTERS.		ADJUTANTS.		QR. MASTERS.		SURGS.		ASSIST. SURGS.		VETERINARY SURGS.		TOTAL.		REMARKS.
	Strength.	Deaths.	Strength.	Deaths.	Strength.	Deaths.	Strength.	Deaths.	Strength.	Deaths.	Strength.	Deaths.	Strength.	Deaths.	Strength.	Deaths.	Strength.	Deaths.	Strength.	Deaths.	Strength.	Deaths.	Strength.	Deaths.	
1814	22	0	22	0	110	1	238	6	92	0	11	0	11	0	11	0	11	0	22	0	22	2	552	6	No Returns for 5 months of this year. 1 Lieut. killed in action. 1 Major, 1 Captain and 1 Lt. killed in action. 1 Major do. do. 1 Lieut. killed in action. 2 Captains do. 2 Lieuts. do. 10 Officers killed in action.
1815	22	1	22	0	108	1	232	8	90	2	11	0	11	0	11	0	11	0	22	1	22	2	542	13	
1816	22	1	22	0	106	3	230	6	88	1	11	0	11	0	11	0	11	0	22	0	22	2	536	11	
1817	20	3	20	1	98	4	213	14	82	1	10	0	10	0	10	0	10	0	20	0	20	2	495	24	
1818	22	0	22	1	106	6	230	12	88	4	11	2	11	0	11	1	11	1	22	0	22	2	536	27	
1819	20	0	20	2	92	7	200	13	76	3	9	0	9	1	9	1	9	0	20	1	20	2	466	28	
1820	16	1	16	2	78	0	170	9	64	2	8	1	8	0	8	1	8	0	16	0	16	1	393	16	
1821	16	0	16	1	78	1	170	6	64	1	8	0	8	0	8	1	8	0	16	4	16	1	393	14	
1822	18	1	18	0	90	1	195	8	73	1	9	0	9	0	9	1	9	0	18	1	18	1	449	13	
1823	16	1	16	0	78	1	170	5	64	0	8	0	8	0	8	0	8	0	16	0	16	1	393	7	
1824	18	0	18	1	87	5	180	9	71	1	9	0	9	0	9	1	9	1	18	2	18	1	439	20	
1825	19	1	19	0	93	4	203	14	76	6	10	0	10	0	10	0	10	1	19	2	19	1	470	27	
1826	18	0	18	1	88	4	192	18	72	3	9	2	9	0	9	0	9	0	18	0	18	1	443	28	
1827	18	1	18	0	88	10	192	5	72	0	9	0	9	0	9	0	9	0	18	2	18	1	443	18	
1828	18	1	18	0	91	1	199	4	74	2	9	0	9	0	9	1	9	0	18	0	18	1	455	9	
1829	18	2	18	1	80	5	176	1	64	2	9	0	9	0	9	0	9	0	18	0	18	1	411	11	
1830	18	0	18	1	80	1	176	6	64	0	9	0	9	0	9	1	9	0	18	0	18	1	411	9	
1831	18	0	18	1	80	4	176	2	64	1	9	0	9	0	9	0	9	0	18	2	18	1	411	10	
1832	18	3	18	0	82	5	181	2	65	0	9	0	9	0	9	0	9	1	18	0	18	1	419	11	
1833	18	0	18	0	82	12	181	4	65	2	9	0	9	0	9	1	9	1	18	3	18	1	419	22	
Total,.....	375	16	375	12	1796	76	3914	151	1468	31	187	6	187	1	187	8	187	5	375	18	375	26	9076	324	3.65
Percentage,	4.26		3.20	4.23	3.85	2.11	2.67	0.53	4.37	2.67	4.80	4.00													

the Decrements among Officers of His Majesty's Regiments on the Bombay Establishment, from the year 1814 to 1833 inclusive.

JUNTS.	QR. MAS-TERS.		SURGS.		ASSIST. SURGS.		VETERINARY SURGS.		TOTAL.		REMARKS.
	Deaths.	Strength.	Deaths.	Strength.	Deaths.	Strength.	Deaths.	Strength.	Deaths.	Strength.	
1	0	4	1	4	1	8	1	1	0	201	14
1	0	4	1	4	0	8	1	1	1	198	6
1	0	4	1	4	0	8	1	1	0	193	8
1	0	4	0	4	0	6	0	1	0	143	4
1	0	4	0	4	0	10	0	1	0	243	8
1	0	4	1	4	0	8	1	1	0	193	14
1	0	4	1	4	2	8	1	1	0	193	12
4	0	4	0	4	1	8	1	1	0	193	5
5	0	4	1	4	1	10	2	2	0	236	10
4	0	4	0	4	0	8	1	1	0	193	4
3	0	3	1	3	1	7	1	1	1	163	7
5	0	5	1	5	0	9	1	1	0	220	7
4	0	4	1	4	1	8	1	1	0	193	4
4	0	4	0	4	0	8	1	1	0	193	2
4	0	4	0	4	0	8	1	1	0	193	2
5	0	5	0	5	0	10	1	1	0	227	2
5	0	5	0	5	1	10	2	1	0	227	8
5	0	5	0	5	0	10	0	1	0	227	6
5	0	5	0	5	0	10	0	1	0	227	4
5	0	5	1	5	1	10	1	1	0	227	7
7	0	87	10	87	9	172	6	21	2	4083	134
....	11.50	10.34	3.48	9.52	3.28						

1 Major, 1 Lieut. and 1 Ensign killed in action.  
1 Ensign killed in action.  
4 Officers killed in action.

\* Agrees with 60 years of age in the Northampton Table, which has been adopted from this year.

Age	1814	1815	1816	1817	1818	1819	1820	1821	1822	1823	1824	1825	1826	1827	1828	1829	1830	1831	1832	1833
72	0	1	1	1	1	1	1	1	1	1	1	1	1	1	1	1	1	1	1	1
73	0	1	1	1	1	1	1	1	1	1	1	1	1	1	1	1	1	1	1	1
74	0	1	1	1	1	1	1	1	1	1	1	1	1	1	1	1	1	1	1	1
75	0	1	1	1	1	1	1	1	1	1	1	1	1	1	1	1	1	1	1	1
76	0	1	1	1	1	1	1	1	1	1	1	1	1	1	1	1	1	1	1	1
77	0	1	1	1	1	1	1	1	1	1	1	1	1	1	1	1	1	1	1	1
78	0	1	1	1	1	1	1	1	1	1	1	1	1	1	1	1	1	1	1	1
79	0	1	1	1	1	1	1	1	1	1	1	1	1	1	1	1	1	1	1	1
80	0	1	1	1	1	1	1	1	1	1	1	1	1	1	1	1	1	1	1	1
81	0	1	1	1	1	1	1	1	1	1	1	1	1	1	1	1	1	1	1	1
82	0	1	1	1	1	1	1	1	1	1	1	1	1	1	1	1	1	1	1	1
83	0	1	1	1	1	1	1	1	1	1	1	1	1	1	1	1	1	1	1	1
84	0	1	1	1	1	1	1	1	1	1	1	1	1	1	1	1	1	1	1	1
85	0	1	1	1	1	1	1	1	1	1	1	1	1	1	1	1	1	1	1	1
86	0	1	1	1	1	1	1	1	1	1	1	1	1	1	1	1	1	1	1	1
87	0	1	1	1	1	1	1	1	1	1	1	1	1	1	1	1	1	1	1	1
88	0	1	1	1	1	1	1	1	1	1	1	1	1	1	1	1	1	1	1	1
89	0	1	1	1	1	1	1	1	1	1	1	1	1	1	1	1	1	1	1	1
90	0	1	1	1	1	1	1	1	1	1	1	1	1	1	1	1	1	1	1	1
91	0	1	1	1	1	1	1	1	1	1	1	1	1	1	1	1	1	1	1	1
92	0	1	1	1	1	1	1	1	1	1	1	1	1	1	1	1	1	1	1	1

RESULTS OF AN ENQUIRY RESPECTING THE

TAB. XVIII.—TABLE showing the average rate of Mortality among Gentlemen of the Public Service in India, with the probable expectation of Life, as prepared from the Tables of Messrs. Prinsep, Gordon and Major DeHaviland.

Age.	Mr. H. T. Prinsep's Table of the Bengal Civil Service, for 52 years.		Major DeHaviland's Table of the Madras Army, for 13 years.		Bengal Army from 1760, received from Mr. Gordon.		Total of the Three Tables.		Quinquennial Rate.		Graduated Rate on a radix of 10,000.		Supposed No. living at the middle of the Year.	Sum.	Expectation of Life.
	No. of Lives.	Decrement.	No. of Lives.	Decrement.	No. of Lives.	Decrement.	No. of Lives.	Decrement.	No. of Lives.	Decrement.	No. of Lives.	Decrement.			
18	....	....	951	16	4030	106	4981	122	25314	719	10000	284	9858	246604	24.66
19	....	....	758	4	3875	119	4633	123			9716	276	9578	236746	24.36
20	904	17	813	8	3705	131	5422	156			9140	268	9306	227168	24.06
21	860	21	825	11	3528	129	5213	161			9172	260	9042	217862	23.75
22	792	15	898	17	3375	126	5065	167			8912	253	8765	208820	23.43
23	735	18	1132	26	3218	94	5085	138	8659	228	8545	200035	23.10		
24	669	10	1083	25	3097	73	4849	108	8431	222	8320	191490	22.71		
25	684	8	1152	29	2991	95	4827	132	23906	631	8209	216	8101	183170	22.31
26	593	15	1190	21	2892	87	4675	123			7993	210	7888	175069	21.90
27	557	13	1167	26	2746	91	4470	130			7783	205	7680	167181	21.48
28	532	16	1101	32	2627	97	4260	145			7578	257	7449	159501	21.04
29	503	7	1052	40	2454	89	4009	136			7321	249	7197	152052	20.76
30	479	6	983	34	2237	69	3699	109	18274	622	7072	240	6952	144855	20.48
31	460	13	789	37	2037	70	3286	120			6832	232	6716	137903	20.18
32	431	8	749	47	1840	57	3020	112			6600	224	6488	131187	19.87
33	408	5	629	28	1606	47	2643	80			6376	206	6273	124699	19.55
34	386	7	551	20	1381	48	2318	75			6170	200	6070	118426	19.19
35	356	4	514	20	1251	38	2121	62	10906	354	5970	193	5873	112356	18.82
36	343	6	453	13	1172	45	1968	64			5777	187	5684	106483	18.43
37	315	10	445	24	1096	39	1856	73			5590	181	5499	100799	18.03
38	287	7	347	20	965	20	1590	57			5400	995	5296	95300	17.61
39	266	6	256	15	885	42	1407	63			5184	215	5077	90004	17.36
40	238	9	217	11	732	21	1187	41	6242	260	4969	206	4866	84927	17.09
41	212	9	187	14	680	37	1079	60			4763	198	4664	80061	16.80
42	189	9	176	10	605	20	970	39			4565	190	4465	75397	16.51
43	165	5	161	9	544	24	870	38			4375	195	4277	70932	16.21
44	147	4	160	7	476	22	783	33			4180	186	4087	66655	15.94
45	129	5	170	7	414	15	713	27	3603	161	3994	178	3905	62568	15.68
46	105	7	164	9	381	19	650	35			3816	170	3731	58663	15.37
47	90	1	156	6	343	21	527	28			3646	160	3566	54932	15.06
48	75	4	137	8	301	20	513	32			3486	161	3405	51366	14.73
49	63	2	126	5	262	15	451	22			3325	154	3248	47961	14.42
50	51	0	115	3	241	11	407	14	2090	97	3171	147	3098	44713	14.10
51	42	0	108	5	221	9	371	14			3024	140	2954	41615	13.76
52	36	3	102	5	210	7	348	15			2884	133	2817	39661	13.40
53	27	2	99	7	201	6	327	15			2751	136	2683	35844	13.02
54	22	0	89	4	191	10	302	14			2615	129	2550	33161	12.63
55	17	1	84	5	175	12	276	18	1290	64	2486	123	2425	30611	12.31
56	11	1	65	1	134	7	210	9			2363	117	2304	28186	11.92
57	8	0	59	3	108	5	175	8			2246	111	2191	25882	11.52
58	6	0	49	4	84	7	139	11			2135	145	2052	23691	11.09
59	5	0	39	3	64	5	108	8			1990	135	1923	21629	10.86
60	3	1	31	0	53	5	87	6	455	34	1855	126	1792	19706	10.62
61	....	....	28	0	37	0	66	0			1729	117	1671	17914	10.36
62	....	....	23	3	33	3	56	6			1612	109	1557	16243	10.07
63	....	....	17	0	27	1	44	1			1503	101	1453	14686	9.60
64	....	....	16	2	25	3	41	5			1402	90	1357	13233	9.43
65	....	....	14	1	21	0	35	1	1312	80	1272	11876	9.04		
66	....	....	9	0	21	2	30	2	1232	80	1192	10604	8.60		
67	....	....	9	1	15	0	24	1	1152	80	1112	9412	8.17		
68	....	....	4	0	8	0	12	0	1072	80	1032	8300	7.74		
69	....	....	5	0	6	0	11	0	992	80	952	7268	7.32		
70	....	....	4	0	5	0	9	0	912	80	872	6316	6.92		
71	....	....	3	1	4	0	7	1	839	80	800	5444	6.52		



RESULTS OF AN ENQUIRY RESPECTING THE

TAB. XIX.—STATEMENT showing the number of Officers, Cadets of the different Seasons, who were on the strength of the Bengal Army at the beginning of the years specified, with the number of Retirements, Dismissals, &c. and of the Deaths during the year in question.

Table with columns for years 1814-1823 and sub-columns for Living 1st Jan., Retired, Dismissed, &c., and Dead.





RESULTS OF AN ENQUIRY RESPECTING THE

TAB. XX.—STATEMENT shewing the number of Officers, Cadets of the different Seasons, who were on the strength of the Madras Army at the beginning of the years specified, with the number of Retirements, Dismissals, &c. and of the Deaths during the year in question.

CADETS OF THE SEASON.	IN 1814.			IN 1815.			IN 1816.			IN 1817.			IN 1818.			IN 1819.			IN 1820.			IN 1821.			IN 1822.			IN 1823.								
	Living.	Retired, Dismissed, &c.	Dead.	Living.	Retired, Dismissed, &c.	Dead.	Living.	Retired, Dismissed, &c.	Dead.	Living.	Retired, Dismissed, &c.	Dead.	Living.	Retired, Dismissed, &c.	Dead.	Living.	Retired, Dismissed, &c.	Dead.	Living.	Retired, Dismissed, &c.	Dead.	Living.	Retired, Dismissed, &c.	Dead.	Living.	Retired, Dismissed, &c.	Dead.	Living.	Retired, Dismissed, &c.	Dead.						
1767	4	...	...	4	...	...	4	...	1	3	...	...	3	...	1	2	...	...	2	...	...	2	...	...	2	...	...	2	...	...						
1768	2	...	...	2	...	1	1	...	...	1	...	...	1	...	...	1	...	...	1	...	...	1	...	...	1	...	...	1	...	...						
1769	...	...	...	...	...	...	...	...	...	...	...	...	...	...	...	...	...	...	...	...	...	...	...	...	...	...	...	...	...	...						
1770	10	...	...	10	...	2	8	...	1	7	...	1	6	...	...	6	...	6	...	1	5	...	...	5	...	1	4	...	...							
1771	...	...	...	...	...	...	...	...	...	...	...	...	...	...	...	...	...	...	...	...	...	...	...	...	...	...	...	...	...	...						
1772	3	...	...	3	...	...	3	...	...	3	...	...	3	...	...	3	...	3	...	...	3	...	...	3	...	...	3	...	...	...						
1773	1	...	...	1	...	...	1	...	...	1	...	...	1	...	...	1	...	1	...	...	1	...	...	1	...	...	1	...	...	...						
1774	...	...	...	...	...	...	...	...	...	...	...	...	...	...	...	...	...	...	...	...	...	...	...	...	...	...	...	...	...	...						
1775	3	...	...	3	...	...	3	...	...	3	...	1	2	...	...	2	...	2	...	...	2	...	...	2	...	...	2	...	...	...						
1776	7	...	...	7	...	...	7	...	...	7	...	7	...	2	5	...	5	...	5	...	5	...	5	...	5	...	1	4	...	...						
1777	1	...	...	1	...	...	1	...	...	1	...	...	1	...	...	1	...	1	...	...	1	...	...	1	...	...	1	...	...	...						
1778	6	...	...	6	...	...	6	...	...	6	...	6	...	1	5	...	5	...	1	4	...	...	4	...	1	3	...	...	...	...						
1779	8	...	...	8	...	...	8	...	...	8	...	8	...	8	...	8	...	8	...	1	7	...	...	7	...	7	...	...	...	...						
1780	8	...	...	8	...	1	7	...	1	6	...	...	6	...	...	6	...	...	...	...	...	...	...	...	...	...	...	...	...	...						
1781	4	...	...	4	...	...	4	...	...	4	...	4	...	4	...	1	3	...	3	...	3	...	3	...	3	...	3	...	...	...						
1782	17	...	2	15	...	1	14	...	1	13	...	1	12	...	1	10	...	2	8	...	1	...	7	...	1	6	...	...	...	...						
1783	8	...	...	8	...	...	8	...	...	8	...	2	...	6	...	1	5	...	1	4	...	...	4	...	...	4	...	...	...	...						
1784	...	...	...	...	...	...	...	...	...	...	...	...	...	...	...	...	...	...	...	...	...	...	...	...	...	...	...	...	...	...	...					
1785	1	...	...	1	...	...	1	...	...	1	...	...	1	...	...	...	...	...	...	...	...	...	...	...	...	...	...	...	...	...	...					
1786	1	...	...	1	...	1	...	...	...	1	...	...	...	...	...	...	...	...	...	...	...	...	...	...	...	...	...	...	...	...	...					
1787	1	...	...	1	...	...	1	...	...	1	...	...	...	...	...	...	...	...	...	...	...	...	...	...	...	...	...	...	...	...	...					
1788	10	...	1	9	...	...	9	...	1	8	...	1	7	...	...	7	...	...	...	...	...	...	...	...	...	2	4	...	...	...	...					
1789	8	...	...	8	...	1	7	...	...	7	...	...	7	...	1	6	...	...	6	...	6	...	6	...	6	...	6	...	...	...	...					
1790	29	1	3	25	1	1	23	...	2	21	...	1	20	1	2	17	...	17	...	1	16	...	...	16	...	1	15	...	...	3						
1791	8	...	...	8	...	...	8	...	...	8	...	...	8	...	1	7	...	1	6	...	6	...	6	...	6	...	6	...	...	...	...					
1792	4	...	...	4	...	...	4	...	...	4	...	...	4	...	1	3	...	...	3	...	3	...	3	...	3	...	3	...	...	...	...					
1793	10	...	...	10	...	...	10	...	...	10	...	1	9	...	...	9	...	...	9	...	1	8	...	...	8	...	...	...	...	...	...					
1794	14	...	1	13	...	2	11	...	...	11	...	4	11	...	...	11	...	2	9	...	1	8	...	...	8	...	1	7	...	...	...					
1795	33	...	...	33	...	1	32	...	1	31	...	4	27	1	1	25	...	2	23	1	...	22	...	22	1	...	22	1	...	...	2					
1796	25	...	1	24	...	1	23	...	1	22	...	1	21	...	...	21	...	3	18	...	3	15	...	...	15	...	...	...	...	...	...					
1797	27	...	...	27	...	1	26	...	1	25	...	1	24	...	1	23	...	2	21	...	1	20	...	1	19	...	...	...	...	...	...					
1798	42	2	1	39	...	1	38	1	3	34	...	1	33	...	4	29	...	2	27	...	1	26	...	1	25	1	...	24	...	1	1					
1799	82	...	2	80	...	2	78	1	3	74	...	3	68	2	1	65	...	6	59	...	2	52	...	2	50	...	3	47	1	3	3					
1800	111	...	1	110	...	5	105	2	3	100	2	3	95	1	4	90	...	4	86	...	1	80	...	3	77	2	2	73	...	1	1					
1801	2	...	...	2	...	2	1	...	...	1	...	...	1	...	...	1	...	1	...	...	...	...	...	...	...	...	...	...	...	...	...					
1802	75	1	3	71	...	3	68	...	2	66	...	1	62	...	6	56	...	2	54	...	...	...	...	...	2	46	...	1	45	1	1	1				
1803	81	1	3	77	1	1	75	...	2	73	4	1	68	...	7	61	1	2	58	...	2	49	1	4	51	2	1	48	...	1	1	1				
1804	112	1	3	108	1	1	106	...	3	103	2	4	97	2	9	86	...	3	83	...	1	6	76	2	2	72	1	...	71	...	4	4				
1805	133	2	...	131	1	1	123	1	4	118	...	6	112	4	7	101	1	7	93	...	1	1	87	...	6	81	2	2	77	1	6	1				
1806	123	1	6	116	2	7	108	...	5	103	2	4	97	2	6	89	3	7	79	...	2	6	71	...	6	65	1	4	60	...	6	1				
1807	119	...	2	117	2	3	112	1	3	108	1	9	98	3	13	82	1	6	75	...	1	6	69	1	2	66	...	2	64	1	5	5				
1808	25	...	...	25	1	2	22	...	...	22	...	...	22	...	2	20	1	...	19	...	1	18	...	...	18	...	...	...	...	...	...	...				
1809	46	...	...	46	...	...	46	...	1	45	2	1	42	...	2	40	...	3	37	...	...	...	...	...	...	...	...	...	...	...	...	...				
1810	65	...	3	62	1	1	60	2	...	58	1	6	51	...	7	44	...	1	43	...	1	...	...	...	36	...	1	35	...	...	...	...				
1811	46	2	1	43	...	1	42	...	1	41	...	2	39	...	6	33	...	3	30	...	1	...	...	...	29	...	4	25	...	1	24	...	1			
1812	26	1	...	25	...	...	25	...	...	25	...	...	25	1	3	21	...	...	21	...	...	...	...	...	21	...	...	...	...	...	...	...	1			
1813	19	...	...	19	1	...	18	...	...	18	...	1	17	...	1	16	...	...	15	...	...	...	...	...	15	...	...	...	...	...	...	...	...			
1814	...	...	...	11	1	...	10	...	2	8	...	1	7	...	1	6	...	...	6	...	...	...	...	...	6	...	...	...	...	...	...	...	...			
1815	...	...	...	...	...	...	15	...	...	15	...	...	15	...	1	14	...	1	13	...	...	...	...	1	12	...	...	...	...	...	...	...	...			
1816	...	...	...	...	...	...	...	...	...	18	1	...	17	...	...	17	...	...	17	...	...	...	...	...	1	16	...	...	...	...	...	...	...	...		
1817	...	...	...	...	...	...	...	...	...	...	...	...	88	...	1	87	1	...	77	...	...	...	...	4	73	...	4	69	...	...	69	2	2	2		
1818	...	...	...	...	...	...	...	...	...	...	...	...	...	...	115	...	...	...	112	...	...	...	6	106	...	6	100	...	2	97	1	7	7	7		
1819	...	...	...	...	...	...	...	...	...	...	...	...	...	...	...	...	...	...	240	...	...	...	2	238	...	10	228	...	5	222	1	1	1	1		
1820	...	...	...	...	...	...	...	...	...	...	...	...	...	...	...	...	...	...	...	...	...	...	...	...	...	...	...	...	...	...	...	...	...	...	...	
1821	...	...	...	...	...	...	...	...	...	...	...	...	...	...	...	...	...	...	...	...	...	...	...	...	...	...	...	...	...	...	...	...	...	...	...	
1822	...	...	...	...	...	...	...	...	...	...	...	...	...	...	...	...	...	...	...	...	...	...	...	...	...	...	...	...	...	...	...	...	...	...	...	
1823	...	...	...	...	...	...	...	...	...	...	...	...	...	...	...	...	...	...	...	...	...	...	...	...	...	...	...	...	...	...	...	...	...	...	...	...
1824	...	...	...	...	...	...	...	...	...	...	...	...	...	...	...	...	...	...	...	...	...	...	...	...	...	...	...	...	...	...	...	...	...	...	...	...



TAB. XXI.—STATEMENT shewing the number of Officers, Cadets of the different Seasons, who were on the strength of the Army at the beginning of the years specified, with the number of Retirements, Dismissals, &c. and of the Deaths during the year in question. *Adjutant General's Office, Bombay, 27th June, 1834.*

CADETS OF THE SEASON.	IN 1814.			IN 1815.			IN 1816.			IN 1817.			IN 1818.			IN 1819.			IN 1820.			IN 1821.			IN 1822.			IN 1823.		
	Living.	Retired, Dismissed, &c.	Dead.	Living.	Retired, Dismissed, &c.	Dead.	Living.	Retired, Dismissed, &c.	Dead.	Living.	Retired, Dismissed, &c.	Dead.	Living.	Retired, Dismissed, &c.	Dead.	Living.	Retired, Dismissed, &c.	Dead.	Living.	Retired, Dismissed, &c.	Dead.	Living.	Retired, Dismissed, &c.	Dead.	Living.	Retired, Dismissed, &c.	Dead.			
1769 ...	1	...	1	...	...	...	...	...	...	...	...	...	...	...	...	...	...	...	...	...	...	...	...	...	...	...	...			
1771 ...	1	1	...	...	...	...	...	...	...	...	...	...	...	...	...	...	...	...	...	...	...	...	...	...	...	...	...			
1772 ...	1	...	...	...	...	...	...	...	...	...	...	...	...	...	...	...	...	...	...	...	...	...	...	...	...	...	...			
1775 ...	4	...	...	4	...	...	4	...	4	...	1	3	...	3	...	1	2	...	2	...	...	...	...	...	...	...	...			
1776 ...	2	...	...	2	...	...	2	...	2	...	...	2	...	2	...	...	2	...	2	...	...	...	...	...	...	...	...			
1777 ...	3	...	...	3	...	1	2	...	2	...	...	2	...	2	...	...	2	...	2	...	...	...	...	...	...	...	...			
1778 ...	2	...	...	2	...	...	2	...	2	...	...	2	...	2	...	...	2	...	2	...	...	...	...	...	...	...	1			
1779 ...	3	...	...	3	...	...	3	...	3	...	...	3	...	3	...	...	3	...	3	...	...	...	...	...	1	2	...			
1780 ...	7	...	1	6	...	...	6	...	6	...	1	5	...	1	4	...	...	4	...	1	3	...	...	...	3	...	...			
1781 ...	1	...	...	1	...	1	...	...	1	...	...	...	...	...	...	...	...	...	...	...	...	...	...	...	...	...	...			
1782 ...	4	...	...	4	...	...	4	...	4	...	...	4	...	4	...	1	1	2	...	...	...	2	...	...	2	...	...			
1783 ...	1	...	1	...	...	...	...	...	...	...	...	...	...	...	...	...	...	...	...	...	...	...	...	...	...	...	...			
1788 ...	9	...	...	9	...	...	9	...	2	7	...	7	...	1	6	...	1	5	...	5	...	2	3	...	3	...	3			
1790 ...	2	...	4	1	...	...	1	...	1	...	...	1	...	1	...	...	1	...	1	...	1	...	1	...	...	1	...			
1791 ...	7	...	...	7	...	...	7	...	7	...	...	7	...	1	6	...	...	6	...	6	...	6	...	6	...	2	4			
1792 ...	1	...	...	1	...	...	1	...	1	...	...	...	...	...	...	...	...	...	...	...	...	...	...	...	...	...	...			
1793 ...	2	...	1	1	...	...	...	...	...	...	...	...	...	...	...	...	...	...	...	...	...	...	...	...	...	...	...			
1794 ...	6	...	...	6	...	1	5	...	5	...	...	5	...	5	...	1	4	...	2	2	...	2	...	2	...	2	...			
1795 ...	16	...	...	16	...	...	16	...	16	...	4	12	...	12	...	1	11	...	11	...	...	11	...	11	...	2	9			
1796 ...	11	...	...	11	...	...	11	...	11	...	...	11	...	1	10	...	...	10	...	10	...	1	9	...	2	7	...			
1797 ...	40	2	1	27	...	1	36	...	36	1	1	34	1	2	31	...	1	30	...	30	1	2	27	...	1	26	...			
1799 ...	37	1	2	34	...	...	34	1	33	...	...	33	...	1	32	1	2	29	...	29	...	3	26	...	26	...	...			
1800 ...	47	...	...	47	...	1	46	...	45	2	2	41	...	1	40	2	3	35	...	1	34	...	2	32	2	...	30	...		
1801 ...	4	...	...	4	...	...	4	...	4	...	...	4	...	...	4	...	...	4	...	4	...	2	2	...	2	...	2	...		
1802 ...	21	...	1	2	1	...	19	...	19	...	1	18	...	...	18	...	1	17	2	1	14	...	2	12	...	12	...			
1803 ...	113	1	7	105	2	5	98	1	2	95	2	...	93	...	6	87	1	4	82	...	7	75	...	4	71	1	3	67	1	...
1804 ...	14	...	1	13	...	...	13	...	1	12	...	...	12	...	1	11	...	...	11	...	...	11	...	11	...	11	...	...	...	
1806 ...	14	1	...	13	...	...	13	...	13	...	...	13	...	1	12	...	...	11	...	11	...	11	...	11	...	11	...	...	2	
1807 ...	19	1	3	15	...	...	15	2	...	13	...	...	13	...	1	12	...	...	12	...	...	12	...	12	1	...	11	...	1	
1808 ...	27	...	1	26	...	...	26	...	26	...	...	25	...	1	24	1	1	22	...	1	21	...	1	20	...	1	19	...	...	
1809 ...	17	...	1	16	...	...	16	...	16	...	2	14	...	...	14	...	1	13	...	1	12	...	2	10	...	1	9	...	...	
1810 ...	25	2	...	23	...	...	23	1	...	30	...	1	29	...	...	29	...	1	28	...	...	28	...	28	1	...	27	1	...	
1811 ...	24	...	...	24	...	...	24	1	...	23	...	1	22	...	2	20	...	2	18	1	...	17	...	1	16	...	1	15	...	...
1812 ...	6	...	...	6	...	...	6	...	6	...	...	6	...	...	6	...	...	6	...	6	...	6	...	6	...	6	...	6	...	...
1813 ...	...	...	...	6	...	...	8	...	9	...	...	9	...	...	9	...	...	9	...	9	...	1	8	...	8	...	8	...	...	
1814 ...	...	...	...	...	...	...	...	...	4	...	...	6	...	...	6	...	...	6	...	6	...	6	...	6	...	6	...	6	...	...
1815 ...	...	...	...	...	...	...	...	...	6	...	1	5	...	...	5	...	...	5	...	5	...	5	...	5	...	5	...	5	...	...
1816 ...	...	...	...	...	...	...	...	...	12	...	...	12	...	...	12	...	...	12	...	12	1	...	11	...	1	10	...	...	...	
1817 ...	...	...	...	...	...	...	...	...	...	...	...	62	...	...	62	...	1	61	...	5	56	...	5	51	...	1	50	...	...	
1818 ...	...	...	...	...	...	...	...	...	...	...	...	66	...	...	66	...	1	60	...	5	60	...	1	59	...	1	59	...	1	2
1819 ...	...	...	...	...	...	...	...	...	...	...	...	...	...	...	98	...	1	97	...	1	97	...	3	94	...	1	93	...	1	3
1820 ...	...	...	...	...	...	...	...	...	...	...	...	...	...	...	...	...	...	...	...	...	...	6	112	...	4	108	...	6	...	...
1821 ...	...	...	...	...	...	...	...	...	...	...	...	...	...	...	...	...	...	...	...	...	...	...	...	...	...	...	...	...	...	...
1822 ...	...	...	...	...	...	...	...	...	...	...	...	...	...	...	...	...	...	...	...	...	...	...	...	...	...	...	...	...	...	...
1823 ...	...	...	...	...	...	...	...	...	...	...	...	...	...	...	...	...	...	...	...	...	...	...	...	...	...	...	...	...	...	...
1824 ...	...	...	...	...	...	...	...	...	...	...	...	...	...	...	...	...	...	...	...	...	...	...	...	...	...	...	...	...	...	...
1825 ...	...	...	...	...	...	...	...	...	...	...	...	...	...	...	...	...	...	...	...	...	...	...	...	...	...	...	...	...	...	...
1826 ...	...	...	...	...	...	...	...	...	...	...	...	...	...	...	...	...	...	...	...	...	...	...	...	...	...	...	...	...	...	...
1827 ...	...	...	...	...	...	...	...	...	...	...	...	...	...	...	...	...	...	...	...	...	...	...	...	...	...	...	...	...	...	...
1828 ...	...	...	...	...	...	...	...	...	...	...	...	...	...	...	...	...	...	...	...	...	...	...	...	...	...	...	...	...	...	...
1829 ...	...	...	...	...	...	...	...	...	...	...	...	...	...	...	...	...	...	...	...	...	...	...	...	...	...	...	...	...	...	...
1830 ...	...	...	...	...	...	...	...	...	...	...	...	...	...	...	...	...	...	...	...	...	...	...	...	...	...	...	...	...	...	...
1831 ...	...	...	...	...	...	...	...	...	...	...	...	...	...	...	...	...	...	...	...	...	...	...	...	...	...	...	...	...	...	...
Total,...	492	9	22	467	4	9	456	7	7	473	5	16	516	2	18	562	6	24	630	4	25	719	3	38	736	7	20	748	4	23

Note.—No Returns for the years 1765—68, 1770, 1773, 1774, 1784—87, 1789, 1798, 1805, 1832 and 1833, which are consequently omitted to save space.

TABLE XXI.—Continued.

CADETS OF THE SEASON.	IN 1824.			IN 1825.			IN 1826.			IN 1827.			IN 1828.			IN 1829.			IN 1830.			IN 1831.			IN 1832.			IN 1833.		
	Living.	Retired, Dismissed, &c.	Dead.	Living.	Retired, Dismissed, &c.	Dead.	Living.	Retired, Dismissed, &c.	Dead.	Living.	Retired, Dismissed, &c.	Dead.	Living.	Retired, Dismissed, &c.	Dead.	Living.	Retired, Dismissed, &c.	Dead.	Living.	Retired, Dismissed, &c.	Dead.	Living.	Retired, Dismissed, &c.	Dead.	Living.	Retired, Dismissed, &c.	Dead.	Living.	Retired, Dismissed, &c.	Dead.
1769	...	...	...	...	...	...	...	...	...	...	...	...	...	...	...	...	...	...	...	...	...	...	...	...	...	...	...	...	...	...
1771	...	...	...	...	...	...	...	...	...	...	...	...	...	...	...	...	...	...	...	...	...	...	...	...	...	...	...	...	...	...
1772	...	...	...	...	...	...	...	...	...	...	...	...	...	...	...	...	...	...	...	...	...	...	...	...	...	...	...	...	...	...
1775	2	...	1	1	...	...	1	...	...	...	...	1	...	...	...	...	...	...	...	...	...	...	...	...	...	...	...	...	...	
1776	2	1	1	...	...	...	...	...	...	...	...	...	...	...	...	...	...	...	...	...	...	...	...	...	...	...	...	...	...	
1777	2	...	...	2	...	...	2	...	...	2	...	...	...	...	...	...	...	...	...	...	...	...	...	...	...	...	...	...	...	
1778	1	...	...	1	...	...	1	...	...	1	...	...	1	...	...	1	...	...	...	...	...	...	...	...	...	...	...	...	...	
1779	2	...	...	2	...	...	2	...	...	2	...	...	2	...	...	2	...	...	2	...	...	2	...	...	2	...	...	2	...	
1780	3	...	...	3	...	...	3	...	...	3	1	2	...	1	2	...	1	1	...	1	...	1	...	1	...	1	...	1	...	
1781	...	...	...	...	...	...	...	...	...	...	...	...	...	...	...	...	...	...	...	...	...	...	...	...	...	...	...	...	...	
1782	2	...	...	2	...	...	2	...	...	2	...	...	2	...	...	2	...	...	2	...	...	2	...	...	2	...	...	2	...	
1783	...	...	...	...	...	...	...	...	...	...	...	...	...	...	...	...	...	...	...	...	...	...	...	...	...	...	...	...	...	
1788	3	...	...	3	...	...	3	...	...	3	...	...	3	...	...	3	...	...	3	...	...	3	...	...	3	...	...	3	...	
1790	1	...	...	1	...	...	1	...	...	1	...	...	1	...	...	1	...	...	1	...	...	1	...	...	1	...	...	1	...	
1791	4	...	...	4	...	1	3	...	1	2	...	...	2	...	...	2	...	...	2	...	...	2	...	1	1	...	1	...	1	
1792	...	...	...	...	...	...	...	...	...	...	...	...	...	...	...	...	...	...	...	...	...	...	...	...	...	...	...	...	...	
1793	...	...	...	...	...	...	...	...	...	...	...	...	...	...	...	...	...	...	...	...	...	...	...	...	...	...	...	...	...	
1794	2	...	...	2	...	...	2	...	...	2	...	...	2	...	...	2	...	...	2	...	...	2	...	...	2	...	...	2	...	
1795	8	...	...	8	...	1	7	...	...	7	...	1	6	...	...	6	...	...	6	...	...	6	...	...	6	...	...	6	...	
1796	6	...	...	6	...	1	5	...	...	5	...	...	5	...	...	5	...	...	5	...	...	5	...	...	5	...	...	5	...	
1797	23	1	...	22	...	1	21	...	2	19	...	1	18	1	...	17	1	1	15	...	1	14	...	3	11	...	11	...	...	
1799	26	...	...	26	...	...	26	...	1	25	...	...	25	...	1	24	2	1	21	...	...	21	...	2	19	...	1	18	...	
1800	29	...	1	28	...	2	26	...	2	24	2	...	22	1	...	20	2	...	18	2	1	15	1	1	13	1	1	11	...	
1801	2	...	...	2	...	...	2	...	...	2	...	...	2	...	...	2	...	...	2	...	1	1	...	1	...	1	...	1	...	
1802	12	...	1	11	...	...	11	...	1	10	...	...	10	...	1	9	...	...	9	...	...	9	...	...	9	...	1	8	...	
1803	66	...	2	64	1	2	61	...	3	58	...	5	53	2	3	48	3	3	42	2	...	40	3	1	36	2	2	32	2	4
1804	11	...	...	11	1	2	8	...	2	6	...	...	6	...	...	6	1	1	4	...	...	4	...	...	4	...	1	3	...	
1806	9	...	2	7	1	2	4	...	...	4	...	...	4	...	...	4	...	...	4	1	1	4	...	3	...	3	...	3	...	2
1807	10	1	...	9	...	...	9	...	1	8	...	...	8	...	...	8	...	...	8	...	...	8	...	...	8	...	...	8	...	1
1808	19	...	1	18	...	...	18	...	...	18	1	1	16	...	...	16	...	1	15	...	...	15	...	...	15	...	...	15	...	
1809	9	...	1	8	...	...	8	...	...	8	...	...	8	...	...	8	...	...	8	...	...	8	...	...	8	...	...	8	...	
1810	26	...	1	25	1	1	23	...	...	23	...	...	23	...	...	23	1	1	22	...	...	22	...	1	21	...	1	20	...	
1811	15	...	1	14	...	...	14	...	...	14	1	...	13	...	...	13	1	...	12	...	...	12	...	...	12	...	...	12	...	
1812	6	1	...	5	...	...	5	...	...	5	...	...	5	...	...	5	...	...	5	...	...	5	...	...	5	...	...	5	...	
1813	8	...	...	8	...	2	6	1	...	5	...	...	5	...	...	5	...	...	5	...	1	4	...	...	4	...	...	4	...	
1814	6	...	2	4	...	...	4	...	...	4	1	...	3	...	1	2	...	...	2	...	...	2	...	...	2	...	...	2	...	
1815	5	...	1	4	...	...	4	...	...	4	...	...	4	...	...	4	...	...	3	...	...	3	...	1	2	...	...	2	...	
1816	10	...	1	9	...	...	9	...	...	9	...	...	9	...	...	9	...	...	9	...	...	9	...	...	9	...	...	9	...	
1817	50	...	...	50	...	4	46	3	1	42	1	...	41	1	1	39	1	1	38	1	...	38	1	...	37	1	...	35	...	
1818	56	2	...	53	...	1	52	...	2	48	...	2	46	...	2	42	2	2	38	...	1	37	...	...	37	1	...	36	...	
1819	89	...	3	86	...	4	82	...	2	80	...	4	76	...	2	74	...	1	73	...	4	69	2	2	65	...	1	64	...	
1820	102	1	5	96	...	3	93	3	9	81	2	4	75	2	3	70	...	...	70	...	...	70	1	1	68	...	3	65	...	
1821	58	1	1	54	...	2	52	...	4	48	1	4	43	...	1	42	2	1	39	1	...	38	...	1	37	1	1	35	...	
1822	38	1	7	30	...	...	30	...	2	28	...	1	27	...	1	26	1	...	25	...	...	25	1	2	22	...	...	22	...	
1823	30	1	...	60	...	1	59	...	6	53	...	2	51	2	1	48	1	2	45	...	2	43	1	...	42	1	2	39	...	
1824	...	...	...	22	...	...	22	...	1	21	...	1	20	...	...	20	1	1	18	...	...	18	...	...	18	...	...	18	...	
1825	...	...	...	...	...	90	2	...	5	83	...	...	83	...	1	82	...	2	80	...	1	79	1	2	76	1	3	72	...	
1826	...	...	...	...	...	...	2	52	...	...	...	...	83	...	3	80	...	...	80	2	4	74	...	...	74	3	3	68	1	2
1827	...	...	...	...	...	...	...	...	...	...	...	...	91	...	2	89	...	...	89	3	6	80	1	3	76	...	4	72	...	
1828	...	...	...	...	...	...	...	...	...	...	...	...	...	...	40	...	...	...	40	...	...	39	...	...	39	1	...	38	...	
1829	...	...	...	...	...	...	...	...	...	...	...	...	...	...	...	...	...	...	11	...	...	11	...	...	11	...	1	10	...	
1830	...	...	...	...	...	...	...	...	...	...	...	...	...	...	...	...	...	...	...	...	...	17	...	...	17	...	1	16	...	
1831	...	...	...	...	...	...	...	...	...	...	...	...	...	...	...	...	...	...	...	...	...	...	...	...	18	...	...	18	...	
Total,...	751	10	33	761	4	26	821	6	64	815	11	29	897	9	27	901	18	19	875	13	23	856	12	21	830	12	29	800	3	19

Note.—No Returns for the years 1765—68, 1770, 1773, 1774, 1784—87, 1789, 1798, 1805, 1832 and 1833, which are consequently omitted to save space.











TABLE XXIII.—Continued.

AGE.	1825.			1826.			1827.			1828.			1829.			1830.			1831.			1832.			1833.			TOTAL.			Age.						
	Living.	Retired, Invalided, &c.	Died.	Living.	Retired, Invalided, &c.	Died.	Living.	Retired, Invalided, &c.	Died.	Living.	Retired, Invalided, &c.	Died.	Living.	Retired, Invalided, &c.	Died.	Living.	Retired, Invalided, &c.	Died.	Living.	Retired, Invalided, &c.	Died.	Living.	Retired, Invalided, &c.	Died.	Living.	Retired, Invalided, &c.	Died.	Living.	Retired, Invalided, &c.	Died.							
18	68	1	...	242	...	4	128	...	...	101	...	...	59	...	...	39	...	...	24	...	...	32	...	...	38	...	...	1680	3	15	18						
19	90	...	6	67	...	1	238	...	4	128	...	6	101	...	4	59	...	...	39	...	...	24	...	3	32	...	...	1650	9	66	19						
20	45	...	...	84	...	2	66	...	...	233	...	10	121	...	2	97	...	1	3	59	...	2	38	...	1	21	...	1591	10	49	20						
21	118	1	10	45	...	4	82	...	1	66	...	2	219	...	7	119	...	3	7	93	...	4	57	...	1	1	...	1678	10	66	21						
22	160	2	5	107	...	4	41	...	1	81	...	2	63	...	1	210	...	4	10	109	...	1	2	89	...	1	4	1513	14	52	22						
23	201	1	12	143	...	2	103	...	2	37	...	3	37	...	...	79	...	...	60	...	4	196	...	4	106	...	1	4	1421	16	49	23					
24	88	...	...	188	...	9	139	...	2	4	98	...	2	37	...	2	1	79	...	1	1	56	...	3	188	...	3	1	1395	17	44	24					
25	58	...	4	88	...	1	6	79	...	2	133	...	3	93	...	1	34	...	1	1	78	...	4	52	...	5	184	...	4	1359	16	61	25				
26	13	...	...	54	...	4	81	...	3	166	...	3	128	...	1	4	28	...	1	1	92	...	4	73	...	1	74	...	3	1240	20	30	26				
27	12	...	...	13	...	...	49	...	...	4	75	...	2	159	...	2	3	126	...	...	...	5	88	...	1	1	32	...	...	70	1	2	1258	9	50	27	
28	5	...	...	12	...	...	13	...	...	1	46	...	1	72	...	1	154	...	2	2	121	...	2	5	86	...	4	32	...	...	1213	15	44	28			
29	14	...	1	6	...	...	12	...	...	...	12	...	...	44	...	1	4	71	...	2	1	150	...	1	5	114	...	1	4	82	...	1	7	1197	12	54	29
30	18	...	2	13	...	...	5	...	...	...	12	...	...	11	...	...	39	...	...	...	69	...	1	3	144	...	3	6	109	...	1	1	1062	17	43	30	
31	22	1	1	16	...	2	13	...	1	1	5	...	...	12	...	...	11	...	2	39	...	...	...	64	...	1	2	35	...	3	2	1006	17	42	31		
32	35	...	4	20	...	1	14	...	...	1	11	...	...	...	...	12	...	1	...	9	...	...	...	39	...	1	1	61	...	2	4	899	8	46	32		
33	29	...	2	31	...	1	19	...	...	...	13	...	...	11	...	1	...	6	...	...	...	...	...	9	...	...	...	37	...	2	1	832	11	39	33		
34	17	1	...	27	...	4	30	...	...	...	19	...	1	13	...	1	10	...	...	...	5	...	...	...	11	...	1	...	9	...	1	775	12	27	34		
35	52	...	1	16	...	1	22	...	1	3	30	...	...	18	...	1	12	...	...	...	10	...	...	...	5	...	...	10	...	...	...	753	13	34	35		
36	54	...	4	51	...	1	2	15	...	...	18	...	...	30	...	...	...	...	1	12	...	...	...	...	10	...	...	5	...	...	...	728	9	25	36		
37	64	1	2	50	...	1	48	...	2	3	15	...	...	18	...	30	1	1	16	...	...	1	12	...	...	10	...	1	...	...	...	703	8	33	37		
38	61	...	4	61	...	3	4	49	...	1	43	...	3	15	...	1	18	...	...	28	...	...	1	15	...	...	12	...	...	...	663	8	33	38			
39	44	...	4	57	...	1	3	54	...	1	48	...	2	40	...	1	13	...	...	1	28	...	...	1	15	...	...	1	...	...	...	615	6	32	39		
40	39	...	2	40	...	1	53	...	3	4	52	...	2	46	...	1	39	...	...	1	12	...	...	1	18	...	1	26	...	...	...	570	7	22	40		
41	...	...	...	31	...	2	39	...	...	2	46	...	2	50	...	1	5	45	...	1	2	38	...	...	1	11	...	...	17	...	1	516	7	36	41		
42	62	1	3	...	...	1	29	...	1	1	37	...	4	44	...	...	4	...	...	4	...	2	42	...	3	37	...	...	...	...	495	8	21	42			
43	37	...	2	58	...	5	1	...	...	3	27	...	3	33	...	2	2	44	...	...	5	42	...	3	3	39	...	4	1	37	5	2	466	22	26	43	
44	21	...	2	35	...	2	4	52	...	1	1	...	...	23	...	4	1	29	...	3	39	...	1	36	...	3	34	...	1	3	389	9	22	44			
45	17	1	...	19	...	1	29	...	1	3	50	...	2	...	...	2	...	...	18	...	1	1	26	...	2	1	38	...	3	...	329	16	16	45			
46	15	...	...	16	...	2	18	...	...	1	1	...	2	47	...	...	1	...	...	...	...	...	...	...	2	35	...	...	...	...	272	8	12	46			
47	16	2	3	15	...	...	13	...	...	1	17	...	1	21	...	1	46	...	6	...	1	...	...	...	14	...	1	1	21	...	1	2	218	13	11	47	
48	5	...	...	11	...	1	15	...	2	...	12	...	...	16	...	1	1	20	...	...	39	...	2	...	...	...	...	...	...	...	...	184	6	5	48		
49	8	...	1	7	...	...	10	...	...	1	13	...	...	12	...	...	14	...	...	20	...	1	1	34	...	1	1	...	...	...	...	179	3	11	49		
50	9	...	...	5	...	...	4	...	...	...	9	...	1	13	...	...	13	...	...	12	...	...	...	14	...	1	1	30	...	2	2	169	6	10	50		
51	3	...	...	3	...	...	7	...	...	...	3	...	...	8	...	1	...	13	...	3	12	...	1	13	...	1	13	...	1	3	135	7	10	51			
52	10	...	...	2	...	...	3	...	...	...	7	...	...	3	...	...	7	...	...	...	...	...	10	...	1	10	...	...	...	...	114	1	6	52			
53	6	...	1	10	...	...	2	...	...	...	3	...	...	7	...	...	3	...	...	...	...	7	...	...	...	9	...	...	...	...	102	1	4	53			
54	3	...	...	5	...	1	10	...	...	...	2	...	1	...	...	3	...	...	...	...	...	3	...	...	...	7	...	...	...	...	89	...	1	5	54		
55	1	...	...	3	...	...	4	...	...	...	10	...	...	1	...	...	3	...	...	...	...	7	...	...	3	...	...	...	...	...	81	...	...	55			
56	...	...	...	1	...	...	3	...	...	...	4	...	...	10	...	...	4	...	...	...	...	3	...	...	...	7	...	...	...	...	77	...	...	56			
57	...	...	...	...	...	...	1	...	...	...	3	...	...	4	...	...	10	...	...	...	...	1	...	...	...	3	...	...	...	...	72	...	2	57			
58	...	...	...	...	...	...	...	...	...	...	1	...	...	3	...	...	4	...	...	...	...	10	...	...	...	1	...	...	...	...	65	...	...	58			
59	4	...	...	...	...	...	...	...	...	...	...	...	...	1	...	...	3	...	...	...	...	4	...	1	10	...	...	...	...	...	65	...	7	59			
60	5	...	1	4	...	...	4	...	...	...	...	...	...	...	...	1	...	...	...	...	...	3	...	...	...	10	...	...	...	...	57	...	1	60			
61	3	...	...	4	...	...	4	...	...	...	...	...	...	...	...	...	...	...	...	...	...	1	...	...	...	3	...	...	...	...	56	...	2	61			
62	4	...	...	3	...	...	4	...	1	4	...	...	...	4	...	...	...	...	...	...	...	...	...	...	...	3	...	...	...	...	51	...	3	62			
63	7	...	...	4	...	...	4	...	1	3	...	...	...	2	...	...	3	...	...	...	...	...	...	...	...	1	...	...	...	...	47	...	3	63			
64	3	...	...	7	...	...	4	...	...	...	...	...	...	1	...	3	...	...	...	...	...	...	...	...	...	...	...	...	...	...	46	...	3	64			
65	1	...	...	3	...	...	7	...	...	...	4	...	1	2	...	2	...	...	...	...	3	...	...	...	...	...	...	...	...	...	43	...	2	65			
66	3	...	...	1	...	...	3	...	...	...	7	...	2	1	...	3	...	...	...	...	...	2	...	...	...	...	...	...	...	...	41	...	3	66			
67	2	...	...	3	...	...	1	...	...	...	3	...	1	5	...	3	...	...	...	...	...	2	...	...	...	3	...	...	...	...	38	...	2	67			
68	...	...	...	2	...	...	3	...	...	...	3	...	...	2	...	5	...	...	...	...	...	3	...	1	2	...	...	...	...	...	33	...	4	68			
69	1	...	...	...	...	...	2	...	...	...	3	...	...	2	...	1	...	...	...	...	...	2	...	...	...	...	...	...	...	...	28	...	2	69			
70	3	...	...	...	...	...	...	...	...	...	...	...	...	3	...	...	...	...	...	...	...	...	...	...	...	...	...	...	...	...	26	...	2	70			
71	...	...	...	3	...	...	1	...	...	...	...	...	...	...	...	2	...	...	...	...	...	3	...	...	...	...	...	...	...	...	24	...	2	71			
72	2	...	1	...	...	...	3	...	1	...	...	...	...	...	...	2	...	...	...	...	...	...	...	...	...	...	...	...	...	...	17	...	2	72			
73	...	...	...	1	...	...	...	...	...	...	...	...	...	2	...	...	...	...	...	...	...	...	...	...	...	3	...	...	...	...	13	...	...	73			
74	1	...	...	...	...	...	...	...	...	...	...	...	...	...	...	1	...	...	...	...	...</																

TAB. XXIV.—ABSTRACT STATEMENT shewing the number of Officers at different Ages, and the Casualties occurring at each year of Age among the Officers of the Bombay Army from 1814 to 1833, inclusive.

AGE.	1814.			1815.			1816.			1817.			1818.			1819.			1820.			1821.			1822.			1823.			1824.								
	Living.	Retired, Invalided, &c.	Died.	Living.	Retired, Dismissed, &c.	Died.	Living.	Retired, Invalided, &c.	Died.	Living.	Retired, Invalided, &c.	Died.	Living.	Retired, Invalided, &c.	Died.	Living.	Retired, Invalided, &c.	Died.	Living.	Retired, Invalided, &c.	Died.	Living.	Retired, Invalided, &c.	Died.	Living.	Retired, Invalided, &c.	Died.	Living.	Retired, Invalided, &c.	Died.									
18	...	...	...	...	...	...	...	...	...	...	...	...	...	...	...	...	...	...	...	...	...	...	...	...	...	...	...	...	...	...									
19	6	...	...	6	...	...	...	...	...	...	...	...	62	...	...	66	...	...	98	...	1	118	...	6	58	...	1	39	...	1	30	...	...	1	7				
20	24	...	...	6	...	...	...	...	...	...	...	...	6	...	...	12	...	...	61	...	5	60	...	1	94	...	1	108	...	6	56	...	1	1					
21	25	2	...	24	...	...	6	...	...	...	...	...	5	...	...	5	...	...	12	...	...	56	...	5	59	...	...	93	...	1	102	...	1	5					
22	17	...	1	23	...	...	24	1	...	...	...	...	6	...	...	6	...	...	5	...	...	12	1	51	...	...	1	59	...	1	89	...	1	3					
23	27	...	1	16	...	...	23	1	...	...	...	...	1	...	...	6	...	...	9	...	...	6	...	...	11	...	1	50	...	...	...	...	...	2	1				
24	19	1	3	26	...	...	16	...	...	...	...	...	30	...	2	6	...	...	9	...	...	6	...	...	5	...	...	10	...	...	...	...	...	...	...				
25	14	1	...	15	...	...	26	...	...	...	...	...	16	...	2	29	...	...	20	...	2	6	...	...	9	...	1	6	...	...	...	...	...	...	...				
26	...	...	...	13	...	...	15	2	...	...	...	...	26	...	1	14	...	...	29	...	1	18	1	...	6	...	...	6	...	...	...	...	...	...	...	...			
27	14	...	...	13	...	...	13	...	...	...	...	...	13	...	...	25	...	1	14	...	1	14	...	1	6	...	...	8	...	...	...	...	...	...	...	...			
28	113	1	7	13	...	...	13	...	...	...	...	...	13	...	...	13	...	...	14	...	1	28	...	1	16	...	...	8	...	...	...	...	...	...	...	...			
29	21	...	1	105	2	5	13	...	1	...	...	...	13	...	...	13	...	...	12	...	1	22	...	2	28	...	1	15	...	...	...	...	...	...	...	...			
30	4	...	...	20	1	...	98	1	2	...	...	...	12	...	...	12	...	...	12	...	1	12	...	...	21	...	1	10	...	...	...	...	...	...	...	...			
31	47	...	...	4	...	...	19	...	...	...	...	...	95	2	...	12	...	...	11	...	...	12	...	...	20	...	1	1	...	...	...	...	...	...	...	...			
32	37	1	2	47	...	1	4	...	...	...	...	...	19	...	1	93	...	6	12	...	1	...	...	11	...	...	12	1	...	...	...	...	...	...	...	...			
33	...	...	...	34	...	...	46	...	1	...	...	...	4	...	...	18	...	...	87	1	4	11	...	...	11	...	...	11	...	...	...	...	...	...	...	...			
34	40	2	1	...	...	...	34	1	...	...	...	...	45	2	2	4	...	...	18	...	1	82	...	7	11	...	...	11	...	...	...	...	...	...	...	...			
35	11	...	...	37	...	1	...	...	...	...	...	...	33	...	...	41	...	1	4	...	1	17	2	1	75	...	4	11	...	...	...	...	...	...	...	...			
36	16	...	...	11	...	...	36	...	...	...	...	...	33	...	1	40	2	3	4	...	3	4	...	14	...	2	71	1	3	...	...	...	...	...	...	...			
37	6	...	1	16	...	...	11	...	...	...	...	...	36	1	1	32	...	1	32	...	2	35	...	1	4	...	2	12	...	...	...	...	...	...	...	...			
38	2	...	...	6	...	...	11	...	...	...	...	...	11	...	...	34	1	2	...	...	...	29	...	...	4	...	2	2	...	...	...	...	...	...	...	...	...		
39	1	...	...	1	...	1	6	...	...	...	...	...	16	...	4	11	...	1	31	...	1	...	...	...	34	...	2	2	...	...	...	...	...	...	...	...	...		
40	7	...	...	1	...	...	5	...	...	...	...	...	5	...	...	12	...	...	10	...	...	30	...	...	26	...	...	30	...	...	...	...	...	...	...	...	...		
41	2	...	...	7	...	...	7	...	...	...	...	...	7	...	...	5	...	...	12	...	1	10	...	...	30	1	2	...	...	...	...	...	...	...	...	...	...		
42	...	...	...	1	...	...	1	...	...	...	...	...	1	...	...	5	...	...	5	...	1	11	...	...	10	...	1	27	...	...	...	...	...	...	...	...	...		
43	9	...	...	...	...	...	7	...	...	...	...	...	7	...	...	...	...	...	...	...	...	4	...	2	11	...	9	2	...	...	...	...	...	...	...	...	...		
44	...	...	...	9	...	...	9	...	...	...	...	...	1	...	...	7	1	...	...	...	...	6	...	...	2	...	...	7	...	...	...	...	...	...	...	...	...		
45	...	...	...	...	...	...	2	...	...	...	...	...	7	...	...	1	...	...	...	...	...	...	...	...	2	...	...	2	...	...	...	...	...	...	...	...	...	...	
46	...	...	...	...	...	...	...	...	...	...	...	...	...	...	...	...	...	...	1	...	...	6	...	...	...	...	...	9	...	...	...	...	...	...	...	...	...		
47	...	...	...	...	...	...	...	...	...	...	...	...	7	...	...	1	...	...	...	...	...	1	...	...	6	...	...	...	...	...	...	...	...	...	...	...	...	...	
48	...	...	1	...	...	...	...	...	...	...	...	...	...	...	...	6	...	...	6	...	1	...	...	...	...	...	...	...	...	...	...	...	...	...	...	...	...	...	
49	4	...	...	...	...	...	...	...	...	...	...	...	...	...	...	...	...	...	...	...	...	5	...	...	6	...	2	...	...	...	...	...	...	...	...	...	...	...	
50	1	...	...	4	...	...	...	...	...	...	...	...	...	...	...	...	...	...	...	...	...	...	...	5	...	2	...	...	...	...	...	...	...	...	...	...	...	...	
51	7	...	1	6	...	...	4	1	...	...	...	...	4	...	...	...	...	...	...	...	...	...	...	...	...	3	...	...	...	...	...	...	...	...	...	...	...	...	
52	3	...	...	3	...	...	6	...	1	...	...	...	4	...	...	...	...	...	...	...	...	...	...	...	...	...	...	3	...	...	...	...	...	...	...	...	...	...	
53	2	...	...	3	...	...	3	...	...	...	...	...	...	...	...	...	...	...	...	...	...	...	...	...	...	...	...	...	...	...	...	...	...	...	...	...	...	...	
54	3	...	...	2	...	...	3	...	1	...	...	...	6	...	1	...	...	...	4	1	1	...	...	...	...	...	...	...	...	...	...	...	...	...	...	...	...	...	
55	2	...	...	3	...	...	2	...	...	...	...	...	3	...	...	5	...	1	...	...	...	2	...	...	...	...	...	...	...	...	...	...	...	...	...	...	...	...	
56	4	...	...	2	...	...	2	...	...	...	...	...	2	...	...	3	...	...	4	...	...	2	...	2	...	...	...	...	...	...	...	...	...	...	...	...	...	...	
57	...	...	...	4	...	...	2	...	...	...	...	...	2	...	...	2	...	...	3	...	...	4	...	1	...	2	...	...	...	...	...	...	...	...	...	...	...	...	
58	...	...	...	...	...	...	4	...	...	...	...	...	2	...	...	2	...	...	2	...	...	3	...	...	...	...	...	...	2	...	...	...	...	...	...	...	...	...	
59	1	...	...	...	...	...	4	...	...	...	...	...	4	...	1	...	...	...	2	...	...	2	...	...	3	...	3	...	...	...	...	...	...	...	...	...	...	...	
60	1	1	...	1	...	...	...	...	...	...	...	...	...	...	...	3	...	...	2	...	...	2	...	...	3	...	3	...	1	3	...	...	...	...	...	...	...		
61	...	...	...	...	...	...	1	...	...	...	...	...	...	...	...	...	...	...	3	...	1	2	...	...	2	...	2	...	2	...	...	...	...	...	...	...	...	...	
62	1	...	1	...	...	...	1	...	...	...	...	...	1	...	...	...	...	...	...	...	...	2	...	...	2	...	2	...	2	...	...	...	...	...	...	...	...	...	
63	...	...	...	...	...	...	...	...	...	...	...	...	...	...	...	...	...	...	...	...	...	...	...	...	...	...	...	...	2	...	...	...	...	...	...	...	...	...	
64	...	...	...	...	...	...	...	...	...	...	...	...	...	...	...	1	...	...	...	...	...	...	...	...	...	...	...	...	2	...	...	...	...	...	...	...	...	...	
65	...	...	...	...	...	...	...	...	...	...	...	...	...	...	...	...	...	...	...	...	...	1	...	...	...	...	...	2	...	...	...	...	...	...	...	...	...	...	
66	...	...	...	...	...	...	...	...	...	...	...	...	...	...	...	...	...	...	...	...	...	...	...	1	...	...	...	2	...	...	...	...	...	...	...	...	...	...	...
67	...	...	...	...	...	...	...	...	...	...	...	...	...	...	...	...	...	...	...	...	...	...	...	...	...	...	...	...	...	...	...	...	...	...	...	...	...	...	...
68	...	...	...	...	...	...	...	...	...	...	...	...	...	...	...	...	...	...	...	...	...	...	...	...	...	...	...	...	...	...	...	...	...	...	...	...	...	...	...
69	...	...	...	...	...	...	...	...	...	...	...	...	...	...	...	...	...	...	...	...	...	...	...	...	...	...	...	...	...	...	...	...	...	...	...	...	...	...	...
70	...	...	...	...	...	...	...	...	...	...	...	...	...	...	...	...	...	...	...	...	...	...	...	...	...	...	...	...	...	...	...	...	...	...	...	...	...	...	...
71	...	...	...	...	...	...	...	...	...	...	...	...	...	...	...	...	...	...	...	...	...	...	...	...	...	...	...	...	...	...	...	...	...	...	...	...	...	...	...

TABLE XXIV.—Continued.

AGE.	1825.			1826.			1827.			1828.			1829.			1830.			1831.			1832.			1833.			TOTAL.			Age.	
	Living.	Retired, Invalided, &c.	Died.	Living.	Retired, Invalided, &c.	Died.	Living.	Retired, Invalided, &c.	Died.	Living.	Retired, Invalided, &c.	Died.	Living.	Retired, Invalided, &c.	Died.	Living.	Retired, Invalided, &c.	Died.	Living.	Retired, Invalided, &c.	Died.	Living.	Retired, Invalided, &c.	Died.	Living.	Retired, Invalided, &c.	Died.	Living.	Retired, Invalided, &c.	Died.		
18	22	...	...	90	2	5	52	...	...	91	...	2	40	...	...	11	...	...	17	...	...	18	...	...	...	...	...	824	2	17	18	
19	60	...	1	22	...	1	83	...	...	83	...	3	89	...	...	40	1	...	11	...	...	17	...	...	...	...	...	885	3	27	19	
20	30	...	...	59	...	6	21	...	...	83	...	1	80	...	...	89	3	6	39	...	...	11	...	1	16	...	...	866	4	29	20	
21	54	...	2	30	...	2	53	...	2	20	...	...	82	...	2	80	2	4	80	1	3	39	1	...	10	...	...	805	8	28	21	
22	96	...	3	52	...	4	28	...	1	51	...	2	1	20	1	1	80	...	1	74	...	76	...	4	38	...	...	816	5	24	22	
23	86	...	4	93	...	3	9	48	1	4	27	1	1	48	1	2	18	...	79	1	2	74	3	3	72	...	4	707	12	33	23	
24	53	...	1	82	...	2	81	2	4	43	...	1	26	1	...	45	...	2	18	...	...	76	1	3	68	1	2	691	6	21	24	
25	50	...	...	52	...	4	80	...	2	75	2	3	42	2	1	25	...	...	43	1	...	18	...	2	72	...	2	613	6	22	25	
26	9	...	...	50	...	4	48	...	2	76	...	2	70	...	...	39	1	...	25	1	2	42	1	2	16	...	...	515	6	15	26	
27	4	...	...	9	...	...	46	3	1	46	...	4	74	...	1	70	...	...	38	...	1	22	...	...	39	...	...	492	3	13	27	
28	4	...	...	4	...	...	9	...	...	42	1	...	42	2	2	73	...	4	70	1	1	37	1	1	22	...	1	550	7	20	28	
29	8	...	2	4	...	...	4	1	1	9	...	...	41	1	1	38	...	1	69	2	2	68	...	3	35	...	...	523	7	21	29	
30	5	...	...	6	...	1	4	1	...	3	...	...	9	...	...	39	1	...	37	...	...	65	...	1	65	...	2	464	6	9	30	
31	14	...	...	5	...	...	5	...	...	3	...	1	3	...	...	9	...	...	38	1	...	37	1	...	64	...	...	433	4	3	31	
32	25	1	1	14	...	...	5	...	...	5	...	...	2	...	...	3	...	...	9	...	...	37	...	2	36	...	1	399	3	16	32	
33	8	...	...	23	...	...	14	1	...	5	...	...	5	...	...	2	...	...	3	...	1	9	...	...	35	...	...	345	2	8	33	
34	18	...	...	8	...	...	23	...	...	13	...	...	5	...	...	5	...	1	2	...	...	2	...	...	9	...	...	340	6	14	34	
35	9	...	...	18	...	...	8	...	...	23	...	...	13	1	...	5	...	...	4	...	...	2	...	...	2	...	...	322	3	9	35	
36	7	1	2	9	...	1	18	1	1	8	...	...	23	...	1	12	...	...	5	...	...	4	...	...	...	...	...	324	5	14	36	
37	...	...	...	4	...	...	8	...	...	16	...	...	8	...	...	22	...	...	12	...	...	5	...	...	4	...	...	312	3	5	37	
38	11	1	2	...	...	...	4	...	...	8	...	...	16	...	1	8	...	...	22	...	1	12	...	...	5	...	...	298	2	12	38	
39	64	1	2	8	...	...	4	...	...	4	...	...	8	...	...	15	...	...	8	...	...	21	...	1	12	...	...	280	4	12	39	
40	11	...	...	61	...	3	6	...	...	...	...	...	4	...	...	8	...	...	15	...	...	8	...	...	20	...	...	256	...	4	40	
41	2	...	...	11	...	1	58	...	5	6	...	...	...	...	...	4	1	...	8	...	...	15	...	...	8	...	...	234	2	12	41	
42	28	...	2	2	...	...	10	...	...	53	2	3	6	1	1	...	...	...	3	...	...	8	...	...	15	...	...	212	3	9	42	
43	26	...	...	26	...	2	2	...	...	10	...	1	48	3	3	4	...	...	...	...	...	3	...	...	8	...	...	194	5	11	43	
44	...	...	...	26	...	1	24	2	...	2	...	...	9	...	...	42	2	...	4	...	...	...	...	...	3	...	...	170	6	4	44	
45	22	...	1	...	...	...	25	...	...	22	1	1	2	...	...	9	...	...	40	3	1	4	...	1	...	...	157	4	7	45		
46	6	...	1	21	...	2	...	...	...	25	...	1	20	2	...	2	...	...	1	9	...	36	2	2	3	...	...	146	4	7	46	
47	8	...	1	5	...	...	19	...	1	...	...	...	24	2	1	18	2	1	...	9	...	9	...	1	32	2	4	133	6	10	47	
48	2	...	...	7	...	...	5	...	...	18	1	...	...	...	...	21	...	...	15	1	1	1	...	...	8	...	...	80	2	4	48	
49	...	...	...	2	...	...	7	...	1	5	...	...	17	1	1	...	...	...	21	...	2	13	1	1	...	...	...	80	2	5	49	
50	...	...	...	...	...	...	2	...	...	...	...	...	5	...	...	15	...	...	...	...	...	19	1	...	11	...	...	73	1	3	50	
51	4	...	1	...	...	...	...	...	...	2	...	...	6	...	...	5	...	...	14	...	3	...	...	...	18	...	...	65	...	5	51	
52	1	...	...	3	...	1	...	...	...	...	...	...	2	...	...	6	...	...	5	...	...	11	...	...	...	...	...	45	1	1	52	
53	...	...	...	1	...	...	2	...	...	...	...	...	...	...	...	2	...	...	6	...	...	5	...	...	11	...	...	45	...	...	53	
54	3	...	...	...	...	...	1	...	...	2	...	...	...	...	...	...	...	...	2	...	...	6	...	...	5	...	...	37	1	2	54	
55	...	...	...	3	...	...	...	...	...	1	...	...	2	...	...	...	...	...	...	...	...	2	...	...	6	...	...	31	...	2	55	
56	...	...	...	...	...	...	3	...	...	...	...	...	1	...	...	2	...	...	...	...	...	...	...	2	...	...	...	27	...	...	56	
57	...	...	...	...	...	...	...	...	...	3	...	...	...	...	...	1	...	1	2	...	1	...	...	...	...	...	...	25	...	3	57	
58	...	...	...	...	...	...	...	...	...	...	...	...	3	...	...	...	...	...	...	...	...	1	...	...	...	...	...	22	...	...	58	
59	...	...	...	...	...	...	...	...	...	...	...	...	...	...	...	3	...	...	...	...	...	...	...	...	1	...	1	23	...	2	59	
60	2	...	...	2	...	...	...	...	...	...	...	...	...	...	...	...	...	...	3	...	...	3	...	...	...	...	...	22	1	1	60	
61	...	...	...	...	...	...	...	...	...	...	...	...	...	...	...	...	...	...	...	...	...	...	...	...	...	...	...	20	...	1	61	
62	3	...	...	...	...	...	2	...	...	...	...	...	...	...	...	...	...	...	...	...	...	...	...	...	3	...	...	20	...	2	62	
63	2	...	...	3	...	...	...	...	...	2	...	...	...	...	...	...	...	...	...	...	...	...	...	...	...	...	...	15	...	...	63	
64	1	...	...	2	...	...	3	...	1	...	...	...	2	...	...	...	...	...	...	...	...	...	...	...	...	...	...	15	...	1	64	
65	2	...	...	1	...	...	2	...	...	2	...	1	...	...	...	2	...	...	...	...	...	...	...	...	...	...	...	14	1	2	65	
66	...	...	...	2	...	2	1	...	...	2	...	...	1	...	...	...	...	...	2	...	...	...	...	...	...	...	...	11	1	3	66	
67	1	...	...	...	...	...	...	...	...	1	...	...	2	...	...	1	...	...	...	...	...	2	...	...	...	...	...	7	...	...	67	
68	...	...	...	1	...	...	...	...	...	...	...	...	1	...	1	2	...	...	1	...	...	...	...	...	2	...	...	7	...	1	68	
69	...	...	...	...	...	...	1	...	...	...	...	...	...	...	...	...	...	...	2	...	...	1	...	...	...	...	...	4	...	...	69	
70	...	...	...	...	...	...	...	...	...	...	...	1	...	...	...	...	...	...	...	...	...	2	...	...	...	...	...	4	...	1	70	
71	...	...	...	...	...	...	...	...	...	...	...	...	...	...	...	...	...	...	...	...	...	...	...	...	...	2	...	...	2	...	...	71

## TAB. XXVI.—CENSUS of the ARMENIAN POPULATION of Calcutta.

[The present information, obtained from our associate Mr. JOHANNES AVDALL, is added to the foregoing rather because it is useful to record any thing connected with the Statistics of India, than as furnishing new data for the calculation of the rates of Mortality among Europeans in India. The number of the Armenian community is too small to admit of average deductions.—J. P. Sec.]

	<i>Males.</i>	<i>Females.</i>	<i>Total.</i>
Total Armenian inhabitants in 1814, according to the Census made by Mr. GENTLUM AVIET,...	269	195	464
The same carefully revised in 1815, .....	272	208	480
Present population, taken by Mr. AVDALL, 1836,.....	290	215	505
Of whom there are—			
{ adults,.....			313
{ children,.....			192
The number of houses occupied by Armenians is .....			101
Making the inmates per house exactly,.....			5

*REGISTER of Births, Marriages, and Deaths of the Armenian population of Calcutta, comprehending a period of twenty-five years, reckoning from A. D. 1814 to 1835 inclusive.*

Years.	Births.	Marriages.	Deaths.	Duration of individual life, reckoning from the year 1827 to 1835 inclusive.
1811 .....	10	7	12	
1812 .....	8	2	12	
1813 .....	8	4	14	
1814 .....	13	5	21	
1815 .....	9	4	21	
1816 .....	11	7	15	
1817 .....	13	2	10	
1818 .....	11	3	20	
1819 .....	5	1	23	
1820 .....	11	5	17	
1821 .....	16	4	16	
1822 .....	12	5	16	
1823 .....	8	2	10	
1824 .....	7	6	21	
1825 .....	15	5	12	
1826 .....	8	3	19	
1827 .....	18	5	15	28-60-41-1-2-17-45-1-1-37-60-60-1-40-62
1828 .....	12	4	15	21-34-76-1-19-64-1-1-5-37-50-125-15-35
1829 .....	18	2	12	24-30-10-48-16-56-30-22-1-30-75-1
1830 .....	9	4	14	50-40-70-1-2-20-15-9-42-40-35-1-67-7
1831 .....	19	3	17	60-1-31-50-85-1-7-1-1-1-32-55-1-4-47-42-50
1832 .....	13	2	17	30-1-22-1-1-45-2-1-27-1-36-73-1-50-50-54-55
1833 .....	13	3	23	7-1-1-60-40-53-55-87-45-30-85-14-38-25-40-30-20-40-20-56-1-65-30
1834 .....	9	7	16	35-75-1-47-50-56-62-50-39-28-16-6-58-1-74
1835 .....	10	4	7	23-87-20-61-62-41-16
Total, ...	286	99	396	

END OF FIRST PART—TWENTIETH VOLUME.

Printed at the Bengal Military Orphan Press, by G. H. Huttman.







LAW OF MORTALITY, FOR BRITISH INDIA.

TABLE XIX.—Continued.

CADDERS OF THE SEASON.	IN 1824.		IN 1825.		IN 1826.		IN 1827.		IN 1828.		IN 1829.		IN 1830.		IN 1831.		IN 1832.		IN 1833.		
	Living 1st Jan.	Retired, Dismissed, &c.	Living 1st Jan.	Retired, Dismissed, &c.	Living 1st Jan.	Retired, Dismissed, &c.	Living 1st Jan.	Retired, Dismissed, &c.	Living 1st Jan.	Retired, Dismissed, &c.	Living 1st Jan.	Retired, Dismissed, &c.	Living 1st Jan.	Retired, Dismissed, &c.	Living 1st Jan.	Retired, Dismissed, &c.	Living 1st Jan.	Retired, Dismissed, &c.	Living 1st Jan.	Retired, Dismissed, &c.	
1761 ...	...	...	...	...	...	...	...	...	...	...	...	...	...	...	...	...	...	...	...	...	...
1765 ...	...	...	...	...	...	...	...	...	...	...	...	...	...	...	...	...	...	...	...	...	...
1766 ...	2	...	...	...	...	...	...	...	...	...	...	...	...	...	...	...	...	...	...	...	...
1767 ...	...	...	...	...	...	...	...	...	...	...	...	...	...	...	...	...	...	...	...	...	...
1768 ...	...	...	...	...	...	...	...	...	...	...	...	...	...	...	...	...	...	...	...	...	...
1769 ...	...	...	...	...	...	...	...	...	...	...	...	...	...	...	...	...	...	...	...	...	...
1770 ...	...	...	...	...	...	...	...	...	...	...	...	...	...	...	...	...	...	...	...	...	...
1771 ...	6	3	3	1	...	...	...	...	...	...	...	...	...	...	...	...	...	...	...	...	...
1772 ...	1	...	...	...	...	...	...	...	...	...	...	...	...	...	...	...	...	...	...	...	...
1773 ...	1	...	...	...	...	...	...	...	...	...	...	...	...	...	...	...	...	...	...	...	...
1774 ...	1	...	...	...	...	...	...	...	...	...	...	...	...	...	...	...	...	...	...	...	...
1775 ...	...	...	...	...	...	...	...	...	...	...	...	...	...	...	...	...	...	...	...	...	...
1776 ...	1	...	...	...	...	...	...	...	...	...	...	...	...	...	...	...	...	...	...	...	...
1777 ...	4	1	3	2	...	...	...	...	...	...	...	...	...	...	...	...	...	...	...	...	...
1778 ...	8	8	8	8	...	...	...	...	...	...	...	...	...	...	...	...	...	...	...	...	...
1779 ...	4	4	4	4	...	...	...	...	...	...	...	...	...	...	...	...	...	...	...	...	...
1780 ...	7	7	7	7	...	...	...	...	...	...	...	...	...	...	...	...	...	...	...	...	...
1781 ...	13	2	11	7	...	...	...	...	...	...	...	...	...	...	...	...	...	...	...	...	...
1782 ...	8	8	8	8	...	...	...	...	...	...	...	...	...	...	...	...	...	...	...	...	...
1783 ...	15	1	14	3	...	...	...	...	...	...	...	...	...	...	...	...	...	...	...	...	...
1790 ...	3	3	3	3	...	...	...	...	...	...	...	...	...	...	...	...	...	...	...	...	...
1793 ...	11	1	10	10	...	...	...	...	...	...	...	...	...	...	...	...	...	...	...	...	...
1794 ...	20	1	19	18	...	...	...	...	...	...	...	...	...	...	...	...	...	...	...	...	...
1795 ...	24	1	24	24	...	...	...	...	...	...	...	...	...	...	...	...	...	...	...	...	...
1796 ...	10	1	9	9	...	...	...	...	...	...	...	...	...	...	...	...	...	...	...	...	...
1797 ...	12	4	57	7	...	...	...	...	...	...	...	...	...	...	...	...	...	...	...	...	...
1798 ...	65	4	4	4	...	...	...	...	...	...	...	...	...	...	...	...	...	...	...	...	...
1799 ...	37	2	34	1	...	...	...	...	...	...	...	...	...	...	...	...	...	...	...	...	...
1800 ...	52	1	49	2	...	...	...	...	...	...	...	...	...	...	...	...	...	...	...	...	...
1801 ...	13	...	13	13	...	...	...	...	...	...	...	...	...	...	...	...	...	...	...	...	...
1802 ...	15	...	14	13	...	...	...	...	...	...	...	...	...	...	...	...	...	...	...	...	...
1803 ...	68	...	68	65	...	...	...	...	...	...	...	...	...	...	...	...	...	...	...	...	...
1804 ...	108	3	8	97	...	...	...	...	...	...	...	...	...	...	...	...	...	...	...	...	...
1805 ...	114	1	9	111	...	...	...	...	...	...	...	...	...	...	...	...	...	...	...	...	...
1806 ...	79	1	2	76	...	...	...	...	...	...	...	...	...	...	...	...	...	...	...	...	...
1807 ...	77	1	4	72	...	...	...	...	...	...	...	...	...	...	...	...	...	...	...	...	...
1808 ...	78	1	2	75	...	...	...	...	...	...	...	...	...	...	...	...	...	...	...	...	...
1809 ...	55	...	9	46	...	...	...	...	...	...	...	...	...	...	...	...	...	...	...	...	...
1810 ...	58	...	8	55	...	...	...	...	...	...	...	...	...	...	...	...	...	...	...	...	...
1811 ...	32	...	3	32	...	...	...	...	...	...	...	...	...	...	...	...	...	...	...	...	...
1812 ...	10	...	1	9	...	...	...	...	...	...	...	...	...	...	...	...	...	...	...	...	...
1813 ...	31	...	1	31	...	...	...	...	...	...	...	...	...	...	...	...	...	...	...	...	...
1814 ...	18	...	1	18	...	...	...	...	...	...	...	...	...	...	...	...	...	...	...	...	...
1815 ...	18	...	1	17	...	...	...	...	...	...	...	...	...	...	...	...	...	...	...	...	...
1816 ...	18	...	1	17	...	...	...	...	...	...	...	...	...	...	...	...	...	...	...	...	...
1817 ...	18	...	1	17	...	...	...	...	...	...	...	...	...	...	...	...	...	...	...	...	...
1818 ...	94	2	...	92	...	...	...	...	...	...	...	...	...	...	...	...	...	...	...	...	...
1819 ...	124	2	...	121	...	...	...	...	...	...	...	...	...	...	...	...	...	...	...	...	...
1820 ...	150	2	...	147	...	...	...	...	...	...	...	...	...	...	...	...	...	...	...	...	...
1821 ...	130	2	...	125	...	...	...	...	...	...	...	...	...	...	...	...	...	...	...	...	...
1822 ...	125	2	...	118	...	...	...	...	...	...	...	...	...	...	...	...	...	...	...	...	...
1823 ...	75	...	...	73	...	...	...	...	...	...	...	...	...	...	...	...	...	...	...	...	...
1827 ...	...	...	...	155	...	...	...	...	...	...	...	...	...	...	...	...	...	...	...	...	...
1828 ...	...	...	...	...	...	...	...	...	...	...	...	...	...	...	...	...	...	...	...	...	...
1829 ...	...	...	...	...	...	...	...	...	...	...	...	...	...	...	...	...	...	...	...	...	...
1830 ...	...	...	...	...	...	...	...	...	...	...	...	...	...	...	...	...	...	...	...	...	...
1831 ...	...	...	...	...	...	...	...	...	...	...	...	...	...	...	...	...	...	...	...	...	...
1832 ...	...	...	...	...	...	...	...	...	...	...	...	...	...	...	...	...	...	...	...	...	...
1833 ...	...	...	...	...	...	...	...	...	...	...	...	...	...	...	...	...	...	...	...	...	...

Note.—No Returns for the years 1784—9 and 1791—2, which lines are consequently omitted to save space.



## RESULTS OF AN ENQUIRY RESPECTING THE

TABLE XIX.—STATEMENT showing the number of Officers, Cadets of the different Seasons, who were on the strength of the Bengal Army at the beginning of the years specified, with the number of Retirements, Dismissals, &c. and of the Deaths during the year in question.

CADETS OF THE SEASON.	1814.		1815.		1816.		1817.		1818.		1819.		1820.		1821.		1822.		1823.			
	Living 1st Jan.	Retired, Dismissed, &c.	Living 1st Jan.	Retired, Dismissed, &c.	Living 1st Jan.	Retired, Dismissed, &c.	Living 1st Jan.	Retired, Dismissed, &c.	Living 1st Jan.	Retired, Dismissed, &c.	Living 1st Jan.	Retired, Dismissed, &c.	Living 1st Jan.	Retired, Dismissed, &c.	Living 1st Jan.	Retired, Dismissed, &c.	Living 1st Jan.	Retired, Dismissed, &c.	Living 1st Jan.	Retired, Dismissed, &c.		
1761	1	...	1	...	1	...	1	...	1	...	1	...	1	...	1	...	1	...	1	...	1	...
1765	1	...	1	...	1	...	1	...	1	...	1	...	1	...	1	...	1	...	1	...	1	...
1766	4	...	4	...	4	...	4	...	4	...	4	...	4	...	4	...	4	...	4	...	4	...
1767	1	...	1	...	1	...	1	...	1	...	1	...	1	...	1	...	1	...	1	...	1	...
1768	2	...	2	...	2	...	2	...	2	...	2	...	2	...	2	...	2	...	2	...	2	...
1769	3	...	3	...	3	...	3	...	3	...	3	...	3	...	3	...	3	...	3	...	3	...
1770	8	...	8	...	8	...	8	...	8	...	8	...	8	...	8	...	8	...	8	...	8	...
1771	9	...	9	...	9	...	9	...	9	...	9	...	9	...	9	...	9	...	9	...	9	...
1772	4	...	4	...	4	...	4	...	4	...	4	...	4	...	4	...	4	...	4	...	4	...
1773	1	...	1	...	1	...	1	...	1	...	1	...	1	...	1	...	1	...	1	...	1	...
1774	1	...	1	...	1	...	1	...	1	...	1	...	1	...	1	...	1	...	1	...	1	...
1775	1	...	1	...	1	...	1	...	1	...	1	...	1	...	1	...	1	...	1	...	1	...
1776	1	...	1	...	1	...	1	...	1	...	1	...	1	...	1	...	1	...	1	...	1	...
1777	5	...	5	...	5	...	5	...	5	...	5	...	5	...	5	...	5	...	5	...	5	...
1778	24	...	24	...	24	...	24	...	24	...	24	...	24	...	24	...	24	...	24	...	24	...
1779	11	...	11	...	11	...	11	...	11	...	11	...	11	...	11	...	11	...	11	...	11	...
1780	15	...	15	...	15	...	15	...	15	...	15	...	15	...	15	...	15	...	15	...	15	...
1781	32	...	32	...	32	...	32	...	32	...	32	...	32	...	32	...	32	...	32	...	32	...
1782	20	...	20	...	20	...	20	...	20	...	20	...	20	...	20	...	20	...	20	...	20	...
1783	34	...	34	...	34	...	34	...	34	...	34	...	34	...	34	...	34	...	34	...	34	...
1790	18	...	18	...	18	...	18	...	18	...	18	...	18	...	18	...	18	...	18	...	18	...
1792	34	...	34	...	34	...	34	...	34	...	34	...	34	...	34	...	34	...	34	...	34	...
1793	44	...	44	...	44	...	44	...	44	...	44	...	44	...	44	...	44	...	44	...	44	...
1796	16	...	16	...	16	...	16	...	16	...	16	...	16	...	16	...	16	...	16	...	16	...
1799	22	...	22	...	22	...	22	...	22	...	22	...	22	...	22	...	22	...	22	...	22	...
1798	112	...	112	...	112	...	112	...	112	...	112	...	112	...	112	...	112	...	112	...	112	...
1799	60	...	60	...	60	...	60	...	60	...	60	...	60	...	60	...	60	...	60	...	60	...
1800	86	...	86	...	86	...	86	...	86	...	86	...	86	...	86	...	86	...	86	...	86	...
1801	17	...	17	...	17	...	17	...	17	...	17	...	17	...	17	...	17	...	17	...	17	...
1802	20	...	20	...	20	...	20	...	20	...	20	...	20	...	20	...	20	...	20	...	20	...
1803	107	...	107	...	107	...	107	...	107	...	107	...	107	...	107	...	107	...	107	...	107	...
1804	175	...	175	...	175	...	175	...	175	...	175	...	175	...	175	...	175	...	175	...	175	...
1805	168	...	168	...	168	...	168	...	168	...	168	...	168	...	168	...	168	...	168	...	168	...
1806	109	...	109	...	109	...	109	...	109	...	109	...	109	...	109	...	109	...	109	...	109	...
1807	108	...	108	...	108	...	108	...	108	...	108	...	108	...	108	...	108	...	108	...	108	...
1808	128	...	128	...	128	...	128	...	128	...	128	...	128	...	128	...	128	...	128	...	128	...
1809	87	...	87	...	87	...	87	...	87	...	87	...	87	...	87	...	87	...	87	...	87	...
1810	68	...	68	...	68	...	68	...	68	...	68	...	68	...	68	...	68	...	68	...	68	...
1811	56	...	56	...	56	...	56	...	56	...	56	...	56	...	56	...	56	...	56	...	56	...
1812	12	...	12	...	12	...	12	...	12	...	12	...	12	...	12	...	12	...	12	...	12	...
1813	38	...	38	...	38	...	38	...	38	...	38	...	38	...	38	...	38	...	38	...	38	...
1814	...	...	...	...	...	...	...	...	...	...	...	...	...	...	...	...	...	...	...	...	...	...
1815	...	...	...	...	...	...	...	...	...	...	...	...	...	...	...	...	...	...	...	...	...	...
1816	...	...	...	...	...	...	...	...	...	...	...	...	...	...	...	...	...	...	...	...	...	...
1817	...	...	...	...	...	...	...	...	...	...	...	...	...	...	...	...	...	...	...	...	...	...
1818	...	...	...	...	...	...	...	...	...	...	...	...	...	...	...	...	...	...	...	...	...	...
1819	...	...	...	...	...	...	...	...	...	...	...	...	...	...	...	...	...	...	...	...	...	...
1820	...	...	...	...	...	...	...	...	...	...	...	...	...	...	...	...	...	...	...	...	...	...
1821	...	...	...	...	...	...	...	...	...	...	...	...	...	...	...	...	...	...	...	...	...	...
1822	...	...	...	...	...	...	...	...	...	...	...	...	...	...	...	...	...	...	...	...	...	...
1823	...	...	...	...	...	...	...	...	...	...	...	...	...	...	...	...	...	...	...	...	...	...
1824	...	...	...	...	...	...	...	...	...	...	...	...	...	...	...	...	...	...	...	...	...	...
1825	...	...	...	...	...	...	...	...	...	...	...	...	...	...	...	...	...	...	...	...	...	...
1826	...	...	...	...	...	...	...	...	...	...	...	...	...	...	...	...	...	...	...	...	...	...
1827	...	...	...	...	...	...	...	...	...	...	...	...	...	...	...	...	...	...	...	...	...	...
1828	...	...	...	...	...	...	...	...	...	...	...	...	...	...	...	...	...	...	...	...	...	...
1829	...	...	...	...	...	...	...	...	...	...	...	...	...	...	...	...	...	...	...	...	...	...
1830	...	...	...	...	...	...	...	...	...	...	...	...	...	...	...	...	...	...	...	...	...	...
1831	...	...	...	...	...	...	...	...	...	...	...	...	...	...	...	...	...	...	...	...	...	...
1832	...	...	...	...	...	...	...	...	...	...	...	...	...	...	...	...	...	...	...	...	...	...
1833	...	...	...	...	...	...	...	...	...	...	...	...	...	...	...	...	...	...	...	...	...	...

Note.—No Returns for the years 1784—9 and 1791—2, which lines are consequently omitted to save space.



LAW OF MORTALITY, FOR BRITISH INDIA.

TABLE XXV.—TABLE shewing the average rate of Mortality among Officers of the Indian Army, from the year 1814 to 1833, or for a period of 20 years; with the probable expectation of Life deduced therefrom.

Age.	Bengal Army from 1814 to 1833.		Madras Army from 1814 to 1833.		Bombay Army from 1814 to 1833.		Total of the Indian Army.		Quinquennial Rate.		Percentage.		Graduated Rate on a Basis of 10,000		Supposed No. Living at the middle of the Year.	Sum.	Expectation of Life.	Age.
	No. of Lives.	Decrement.	No. of Lives.	Decrement.	No. of Lives.	Decrement.	No. of Lives.	Decrement.	No. of Lives.	Decrement.	No. of Lives.	Decrement.	No. of Lives.	Decrement.				
18	2071	26	1679	15	823	17	4573	58	22134	574	2.59	10000	259	9871	245636	24.76	13	
19	2020	54	1645	66	884	27	4549	147										
20	1979	37	1566	49	864	29	4429	115										
21	1927	40	1573	66	801	28	4336	134										
22	1927	44	1506	52	814	24	4247	130										
23	1888	36	1413	49	701	33	4002	138										
24	1742	31	1366	44	688	21	3816	96										
25	1709	47	1351	61	610	22	3670	130										
26	1587	39	1230	30	512	15	3332	84										
27	1606	49	1234	50	490	13	3330	112										
28	1506	37	1206	44	547	20	3230	102										
29	1412	38	1191	54	520	21	3132	112										
30	1292	36	1054	43	461	9	2807	88										
31	1235	38	998	42	431	3	2664	81										
32	1142	41	895	46	398	16	2435	103										
33	1116	36	826	29	344	8	2286	83										
34	1031	33	769	37	337	14	2137	74										
35	990	30	747	34	320	9	2019	69										
36	974	35	723	25	322	14	1964	77										
37	955	28	699	33	310	5	1854	77										
38	898	38	659	33	297	12	1721	73										
39	851	30	612	32	278	12	1615	74										
40	792	24	567	22	266	4	1511	71										
41	736	23	542	36	233	12	1377	56										
42	676	26	491	21	210	9	1261	52										
43	579	15	455	26	192	11	1164	44										
44	493	13	380	22	167	4	1041	39										
45	418	14	321	16	155	7	894	37										
46	312	13	268	12	144	7	724	32										
47	220	11	212	11	130	10	562	32										
48	199	8	181	5	79	4	459	18										
49	193	6	177	11	73	5	442	22										
50	203	8	166	11	73	3	430	21										
51	183	3	132	10	65	5	380	18										
52	170	6	114	6	45	1	329	12										
53	157	5	101	4	43	0	300	10										
54	148	5	89	5	37	2	274	12										
55	133	5	81	5	31	2	245	8										
56	108	5	77	2	27	2	212	7										
57	87	7	72	2	25	3	184	9										
58	73	7	65	2	22	0	160	12										
59	60	2	65	0	22	0	162	2										
60	74	4	57	7	23	1	158	13										
61	62	6	56	1	20	1	145	8										
62	74	3	51	2	20	2	140	5										
63	72	2	47	4	15	1	134	8										
64	75	6	46	2	15	1	127	5										
65	70	4	41	3	14	1	126	10										
66	65	4	41	2	11	7	117	10										
67	61	4	38	3	7	1	106	6										
68	47	4	33	2	7	9	87	9										
69	37	4	28	2	4	4	69	4										
70	32	7	26	2	4	1	62	10										
71	21	3	24	2	4	0	47	5										
72	15	8	17	2	2	0	32	4										
73	8	0	13	0	...	...	21	4										
74	6	1	12	0	...	...	18	4										
75	3	0	9	1	...	...	12	4										
76	2	0	6	1	...	...	9	4										
77	3	1	5	1	...	...	7	4										
78	2	0	3	3	...	...	5	4										
79	2	0	0	3	...	...	2	4										
80	...	...	...	...	...	...	...	...	...	...	...	...	...	...	...	...	...	...

\* From the age of 75 the Northampton Table is adopted.

N. B.—This Table should follow the three succeeding ones, but the convenience of the Press required its introduction in this place.—See



TABLE XVII.—TABLE shewing the Decrements among Officers of His Majesty's Regiments on the Bombay Establishment, from the year 1814 to 1833 inclusive.

Year.	LIEUT.-COLS.		MAJORS.		CAPTS.		LIEUTS.		CORNETS AND ENSIGNS.		PAYMASTERS.		ADJUTANTS.		QR. MAS-TERS.		SURGS.		ASSIST. SURGS.		VETERINARY SURGS.		TOTAL.		REMARKS.
	Strength.	Deaths.	Strength.	Deaths.	Strength.	Deaths.	Strength.	Deaths.	Strength.	Deaths.	Strength.	Deaths.	Strength.	Deaths.	Strength.	Deaths.	Strength.	Deaths.	Strength.	Deaths.	Strength.	Deaths.	Strength.	Deaths.	
1814	8	0	8	0	40	1	86	10	34	0	4	0	4	0	4	1	4	1	8	1	1	0	201	14	
1815	8	1	8	0	40	1	84	1	33	1	4	0	4	0	4	1	4	0	8	0	1	1	198	6	
1816	8	0	8	1	38	2	82	2	32	2	4	0	4	0	4	0	4	0	8	1	1	0	193	8	
1817	6	1	6	0	28	0	60	3	24	0	4	0	4	0	4	0	4	0	6	0	1	0	143	4	
1818	10	0	10	0	48	1	104	6	40	1	5	0	5	0	5	0	5	0	10	0	1	0	243	8	
1819	8	1	8	0	38	2	82	8	32	2	4	0	4	0	4	1	4	0	8	0	1	0	193	14	
3 K 1820	8	0	8	1	38	2	82	3	32	3	4	0	4	0	4	1	4	2	8	0	1	0	193	12	} 1 Major, 1 Lieut. and 1 Ensign killed in action.
1821	8	0	8	0	38	0	82	3	32	0	4	1	4	0	4	0	4	1	8	0	1	0	193	5	
1822	10	0	10	0	46	2	98	4	40	1	5	0	5	0	5	2	5	1	10	0	2	0	236	10	
1823	8	0	8	0	38	1	82	3	32	0	4	0	4	0	4	0	4	0	8	0	1	0	193	4	
1824	7	0	7	1	32	2	70	1	27	0	3	0	3	0	3	1	3	1	7	0	1	1	163	7	
1825	9	0	9	0	43	2	93	1	36	2	5	0	5	0	5	1	5	0	9	1	1	0	220	7	} 1 Ensign killed in action.
1826	8	0	8	0	38	0	82	1	32	0	4	1	4	0	4	1	4	1	8	0	1	0	193	4	
1827	8	0	8	1	38	1	82	0	32	0	4	0	4	0	4	0	4	0	8	0	1	0	193	2	
1828	8	0	8	0	38	0	82	2	32	0	4	0	4	0	4	0	4	0	8	0	1	0	193	2	
1829	10	1	10	0	44	0	96	0	36	0	5	0	5	0	5	0	5	0	10	1	1	0	227	2	
1830	10	0	10	1	44	2	96	1	36	1	5	0	5	0	5	0	5	1	10	2	1	0	227	8	
1831	10	0	10	0	44	4	96	0	36	2	5	0	5	0	5	0	5	0	10	0	1	0	227	6	
1832	10	0	10	0	44	0	96	4	36	0	5	0	5	0	5	0	5	0	10	0	1	0	227	4	
1833	10	0	10	0	44	0	96	2	36	3	5	0	5	0	5	1	5	1	10	0	1	0	227	7	
Total,.....	172	4	172	5	691	23	1731	55	670	18	87	2	87	0	87	10	87	9	172	6	21	2	4083	134	} 4 Officers killed in action.
Percentage,	2.32		3.00		3.32		3.17		2.70		2.30		....		11.50		10.34		3.48		9.52		3.28		

LAW OF MORTALITY, FOR BRITISH INDIA.

LAW OF MORTALITY, FOR BRITISH INDIA.

TABLE VI.—STATEMENT of Burials of Europeans and East Indians at the Park Street Protestant Burial Ground, for the Years mentioned, with the Ages of the Deceased, from 1814 to 1833, both inclusive.

Year.	Age at which the Death took place.												Number of Burials in												Total Deaths at the different Ages.
	1814.	1815.	1816.	1817.	1818.	1819.	1820.	1821.	1822.	1823.	1824.	1825.	1826.	1827.	1828.	1829.	1830.	1831.	1832.	1833.					
1	0	2	13	12	16	17	23	23	20	35	40	29	18	24	44	18	19	31	23	29	436				
2	0	4	7	8	9	9	10	10	17	7	12	8	8	11	14	6	6	6	11	12	190				
3	1	0	2	5	5	5	3	3	5	4	3	5	7	7	9	4	2	2	6	5	87				
4	2	0	2	4	4	1	1	4	2	3	4	3	4	2	3	2	0	2	3	2	69				
5	0	0	3	2	3	1	0	0	4	3	0	3	3	3	5	2	1	2	3	4	45				
6	1	0	0	2	3	2	1	0	3	3	4	4	3	1	1	0	0	0	2	3	34				
7	1	1	1	1	0	2	0	0	2	2	0	1	3	3	1	0	0	0	2	2	45				
8	1	0	0	1	1	0	0	0	4	4	1	2	4	4	0	0	0	0	2	3	65				
9	0	0	0	2	1	0	0	1	2	3	0	0	2	0	1	2	1	1	1	2	49				
10	0	0	0	0	0	0	0	0	0	0	0	0	0	0	0	0	0	0	0	0	29				
11	0	0	0	0	0	0	0	0	0	0	0	0	0	0	0	0	0	0	0	0	35				
12	0	2	0	2	1	2	2	2	3	1	2	3	3	2	1	2	2	1	1	4	40				
13	0	1	0	0	0	0	0	0	1	0	1	0	1	1	0	0	0	0	1	1	29				
14	0	2	0	2	1	2	4	2	2	2	3	2	2	2	2	2	2	2	2	1	49				
15	1	1	0	1	1	2	2	2	2	3	4	4	4	5	4	4	4	4	4	4	76				
16	1	0	2	0	1	0	1	3	0	7	6	7	7	8	7	5	5	5	7	7	59				
17	0	0	1	2	0	1	2	3	2	4	4	4	4	4	4	4	4	4	4	4	49				
18	1	1	2	2	3	2	3	5	5	8	6	8	8	8	8	8	8	8	8	8	76				
19	1	3	2	7	7	7	7	12	11	15	13	13	14	14	12	10	10	10	10	10	99				
20	2	3	2	6	6	7	8	12	10	16	14	12	14	12	10	8	7	7	7	7	124				
21	1	6	2	3	5	3	3	7	5	9	6	8	8	8	6	5	4	4	4	4	119				
22	2	2	4	2	4	4	4	6	4	7	5	7	7	7	5	4	4	4	4	4	109				
23	3	3	4	4	4	4	5	8	6	10	8	8	8	8	7	6	6	6	6	6	89				
24	2	4	2	5	6	6	8	11	7	11	11	11	10	12	10	9	9	9	9	9	109				
25	2	4	2	6	7	7	10	14	11	16	13	13	14	12	10	9	8	8	8	8	113				
26	1	4	4	5	6	5	6	8	6	10	6	8	8	8	7	6	6	6	6	6	109				
27	1	4	3	5	6	5	7	9	7	10	6	8	8	8	7	6	6	6	6	6	109				
28	1	4	4	4	4	4	4	5	4	5	4	5	5	4	4	4	4	4	4	4	100				
29	3	3	3	3	3	3	3	3	3	3	3	3	3	3	3	3	3	3	3	3	142				
30	4	4	4	4	4	4	4	4	4	4	4	4	4	4	4	4	4	4	4	4	86				
31	4	4	4	3	3	3	3	3	3	3	3	3	3	3	3	3	3	3	3	3	160				
32	1	4	2	2	3	2	3	4	3	4	3	3	4	4	4	4	4	4	4	4	60				
33	0	1	0	2	2	2	2	2	2	2	2	2	2	2	2	2	2	2	2	2	110				
34	1	2	1	3	5	5	4	4	5	5	6	5	5	5	5	5	5	5	5	5	72				
35	1	5	2	3	14	5	5	5	5	5	6	5	5	5	5	5	5	5	5	5	69				
36	2	6	6	5	14	5	4	4	6	6	6	6	6	6	6	6	6	6	6	6	94				
37	1	2	2	3	3	3	3	3	3	3	3	3	3	3	3	3	3	3	3	3	97				
38	4	4	0	3	8	5	6	8	5	6	7	7	7	7	6	6	6	6	6	6	74				
39	0	4	0	0	3	2	3	4	2	3	3	3	3	3	3	3	3	3	3	3	88				
40	3	3	0	2	5	4	6	13	4	9	5	5	5	5	5	5	5	5	5	5	43				
41	3	4	2	2	5	1	7	7	7	9	9	9	10	9	8	8	8	8	8	8	57				
42	0	3	0	2	2	0	1	1	2	2	1	2	2	2	2	2	2	2	2	2	28				
43	0	0	1	6	2	0	2	2	0	2	0	0	0	0	0	0	0	0	0	0	58				
44	2	2	0	2	2	1	2	2	2	2	2	2	2	2	2	2	2	2	2	2	61				
45	3	4	6	6	4	4	4	4	4	4	4	4	4	4	4	4	4	4	4	4	34				
46	0	4	2	1	3	2	2	2	2	2	2	2	2	2	2	2	2	2	2	2	46				
47	0	0	0	0	0	0	0	0	0	0	0	0	0	0	0	0	0	0	0	0	94				
48	0	0	0	0	0	0	0	0	0	0	0	0	0	0	0	0	0	0	0	0	36				
49	0	1	0	2	2	1	3	3	2	3	3	3	3	3	3	3	3	3	3	3	33				
50	2	4	1	3	2	2	0	0	4	4	0	0	0	0	0	0	0	0	0	0	44				
51	0	6	3	0	1	2	4	4	2	2	2	2	2	2	2	2	2	2	2	2	29				
52	0	1	3	0	0	0	1	1	2	1	1	1	1	1	1	1	1	1	1	1	27				
53	0	0	0	0	0	0	0	0	0	0	0	0	0	0	0	0	0	0	0	0	118				
54	0	0	0	0	0	0	0	0	0	0	0	0	0	0	0	0	0	0	0	0	28				
55	0	1	0	3	0	0	1	2	1	1	1	1	1	1	1	1	1	1	1	1	57				
56	0	0	0	1	0	0	0	0	0	0	0	0	0	0	0	0	0	0	0	0	22				
57	0	0	1	1	0	1	0	0	1	1	1	1	1	1	1	1	1	1	1	1	16				
58	0	0	0	1	0	0	0	0	0	0	0	0	0	0	0	0	0	0	0	0	13				
59	0	0	0	1	0	1	1	1	1	1	1	1	1	1	1	1	1	1	1	1	49				
60	0	0	0	0	0	0	0	0	0	0	0	0	0	0	0	0	0	0	0	0	9				
61	0	0	0	1	1	1	2	2	1	1	1	1	1	1	1	1	1	1	1	1	13				
62	0	0	0	0	0	0	0	0	0	0	0	0	0	0	0	0	0	0	0	0	17				
63	0	0	0	0	0	0	0	0	0	0	0	0	0	0	0	0	0	0	0	0	26				
64	1	0	0	2	0	1	1	1	2	2	1	2	2	2	2	2	2	2	2	2	38				
65	0	0	1	1	0	0	0	0	1	1	1	1	1	1	1	1	1	1	1	1	22				
66	0	0	0	0	0	0	0	0	0	0	0	0	0	0	0	0	0	0	0	0	16				
67	0	0	1	0	1	0	1	1	1	1	1	1	1	1	1	1	1	1	1	1	13				
68	0	0	0	0	0	0	0	0	0	0	0	0	0	0	0	0	0	0	0	0	6				
69	1	0	0	0	0	0	0	0	0	0	0	0	0	0	0	0	0	0	0	0	3				
70 & upwards,	3	2	2	5	2	7	7	4	10	4	7	5	4	9	3	4	4	4	4	4	12				
																					7				
																					119				
																					4308				
No. of Deaths, & Ages specified.....	86	103	139	169	222	253	271	235	310	266	260	286	260	226	227	169	203	183	212	298	345				
Ditto, ditto not specified.....	39	41	58	41	43	21	11	12	14	4	12	8	9	6	1	5	3	3	5	3	4713				
Total number of Deaths.....	125	144	197	210	265	274	282	247	324	270	272	294	269	235	233	160	208	186	217	301	4713				
Same as included in the above.....	0	4	5	4	32	13	26	18	16	13	12	19	15	27	19	6	16	8	6	20	279				









